

## Improving UPQC Capabilities using Energy Storage Devices in DC Link of UPQC

Y. Hoseynpoor, T. PirzadehAshraf, Sh. Sajedi, T. Karimi

Roudehen Branch, Islamic Azad University, Roudehen, Iran

[Yaser.hoseynpoor@gmail.com](mailto:Yaser.hoseynpoor@gmail.com)

**Abstract:** This paper introduces cooperative operation of the unified power quality conditioner (UPQC) with the energy storage system. The proposed system consists of a series inverter, a shunt inverter, and super-capacitors as energy storage devices connected in the dc link through the DC-DC converter. The proposed UPQC can compensate the reactive power, harmonic current, voltage sag and swell, voltage unbalance, and the voltage interruption. A numerical formulation of the proposed control schemes, which are based on the instantaneous power theory, is presented. The performance of proposed system is analyzed through simulations with MATLAB\SIMULINK software. The proposed system can improve the power quality at the common connection point of the non-linear load and the sensitive load.

[Y. Hoseynpoor, T. PirzadehAshraf, Sh. Sajedi, T. Karimi. **Improving UPQC Capabilities using Energy Storage Devices in DC Link of UPQC.** *Academ Arena* 2017;9(3):71-76]. ISSN 1553-992X (print); ISSN 2158-771X (online). <http://www.sciencepub.net/academia>. 6. doi:[10.7537/marsaaj090317.06](https://doi.org/10.7537/marsaaj090317.06).

**Keywords:** Unified power quality conditioner (UPQC), voltage interruption, DC/DC converter, super-capacitor

### 1. Introduction

Since several equipments such as computers, automation equipments, and communication equipments are very sensitive for the input voltage disturbances, the inadequate operation or the fault of these loads brings about huge losses [1-3]. The elimination or mitigation of disturbances propagated from the source side and the other loads interconnected is critical for improving the operational reliability of these critical loads[4-5].

One of the most interesting structures of energy conditioner is two back-to-back connected dc/ac fully controlled converters. In this case, depending on the control scheme, the converters may have different compensation functions. For example, they can function as active series and shunt filters to compensate simultaneously load current harmonics and supply voltage fluctuations. In this case, the equipment is called Unified Power Quality Conditioner (UPQC) [6-8].

Unified Power Quality Conditioner (UPQC) has been widely studied to eliminate or mitigate the disturbances propagated from the source side and the other loads interconnected [9-11]. UPQC has two voltage-source inverters of three-phase four-wire or three-phase three-wire configuration. One inverter called the series inverter is connected through transformers between the source and the common connection point. The other inverter called the shunt inverter connected in parallel with the load. The series inverter operates as a voltage source, while the shunt inverter operates as a current source.

UPQC can simultaneously mitigate the voltage disturbance in source side and the current disturbance in load side. UPQC can compensate voltage sag,

voltage swell, harmonic current, and harmonic voltage, and control the power flow and the reactive power. However, it cannot compensate the voltage interruption because it has no energy storage in the DC link.

This paper proposes a new configuration of UPQC that consists of the DC/DC converter and the super-capacitors for compensating the voltage interruption. The operation of proposed system was verified through simulations with MATLAB\SIMULINK software.

### 2. Configuration of Proposed UPQC

The configuration of proposed UPQC, which additionally has a DC/DC converter and super-capacitors for compensating the voltage interruption. The energy in the DC link charges the super-capacitors through the bi-directional DC/DC converter when the system is in normal operation.

The energy in the super-capacitors is released to the DC link through the bi-directional DC/DC converter when the voltage interruption occurs.

The control system has three major elements which are shunt inverter control, series inverter control, and DC/DC converter control.

When the level of source voltage is maintained as 1.0 p.u., the system works in normal mode. When the level is between 0.5 and 1.0 p.u. or higher than 1.0 p.u., the system works in voltage sag or swell mode. When the level is lower than 0.5 p.u., the system works in interruption mode.

In normal mode, the series inverter injects the zero voltage and the shunt inverter absorbs the current harmonics generated by the load. The DC/DC converter works in charge mode or standby mode

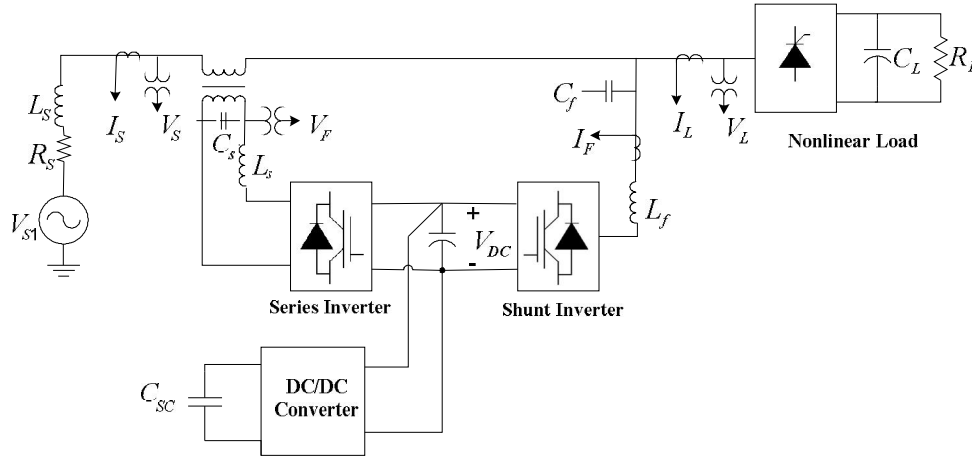

Figure 1. Configuration of proposed UPQC with energy storage

depending on the voltage level of the super-capacitors. In voltage sag or swell mode, the series inverter injects the compensating voltage to maintain the load voltage constant. The shunt inverter absorbs the current harmonics generated by the load and the DC/DC converter works in standby mode. In voltage interruption mode, the series inverter is disconnected from the line and the circuit breaker is opened to isolate the source side. The shunt inverter starts to work as an AC voltage source. The DC/DC converter works in discharge mode to supply the energy stored in the super-capacitors to the load.

The control strategy for the series and shunt inverters of the proposed UPQC has been derived based on the Synchronous reference frame method [11]. The series inverter control compensates the voltage disturbance in the source side due to the fault in the distribution line.

The series inverter control determines the reference voltage to be injected by the series inverter

as shown in fig. 2, using the algorithm described in reference [11]. The shunt inverter control has two functions to compensate the current harmonics and the reactive power in normal operation, and to supply the active power to the load during the voltage interruption.

The first function was described in reference [11] The second function is same as that of the power converter used in power system interconnection. The shunt inverter control has a selective switch as shown in fig. 3, which works in current control mode or voltage control mode under the control of system manager.

The DC/DC converter control works in charge mode or discharge mode selectively, depending on the direction from the system manager. In charge mode, the system manager monitors whether the voltage level of the super-capacitors exceeds the maximum operation voltage or not. If the voltage level reaches the maximum value, the DC/DC converter works in

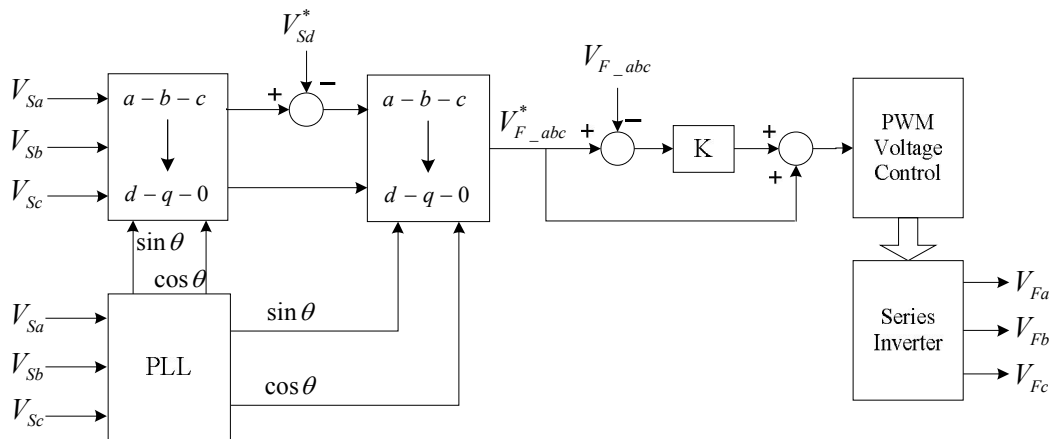

Figure 2. Control block diagram of the shunt converter of the UPQC

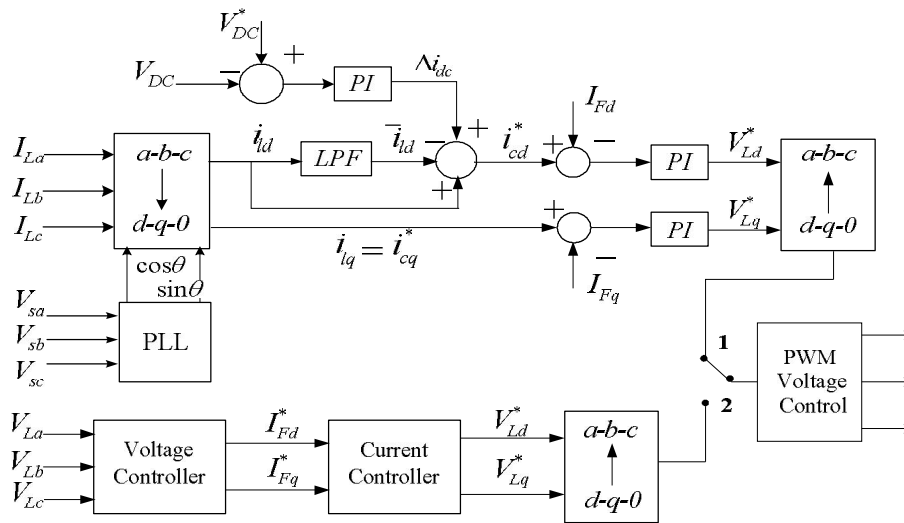

Figure 3. Shunt inverter control block diagram

standby mode. In discharge mode, the system manager monitors whether the voltage level of the super-capacitors drops lower than the minimum operation voltage or not. If the voltage level reaches the minimum value, the DC/DC converter shuts down to stop supplying power to the load.

### 3. DC/DC Converter Design

The DC/DC converter can operate in bi-directional mode using soft-switching Scheme [12-13]. The operation voltage of the super-capacitor bank is in the range between 60-75V, while the dc link voltage is about 700V. The ground point in dc link should be isolated from the ground point in the super-capacitor bank. The converter should have high current rating in bank side and high voltage rating in DC link side. Considering these requirements, a DC/DC converter with two full-bridges was selected as shown in Figure 4.

A filter reactor is inserted between the bank and the full-bridge to reduce the ripple of charging and discharging current, which can reduce the lifetime of super-capacitors due to unwanted heat generation. The full-bridge in bank side works as a current-fed type, while the full-bridge in DC link side works as voltage-fed type.

The DC/DC converter boosts the super-capacitor voltage up to the nominal DC link voltage in discharge mode. The super-capacitor voltage is controlled between 60-75V, while the DC link voltage increases up to 700V. The switches  $S_{C1}$  and  $S_{C2}$  operate with a duty ratio of higher than 0.5. The current through the inductor  $L_f$  increases as all the switches are on conduction-state. The voltage overshoot can be suppressed by turning on auxiliary switch  $S_a$  when two switches in face with diagonal opposition are on conduction state. The current through transformer rises linearly and its peak value

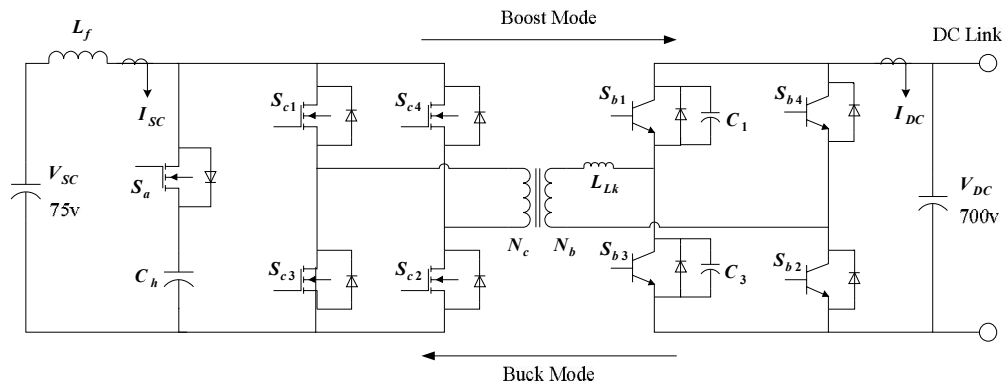

Figure 4. DC/DC converter structure

becomes larger than the current through the boost inductor. When the auxiliary switch turns off, the magnetic energy stored in the leakage inductance of transformer flows through the back-connection diode of the switch in off state. So, the zero-voltage turn-on condition is provided.

The DC/DC converter decreases the nominal DC-link voltage down to the level of super-capacitor voltage in charge mode. When switch  $S_{b1}$  and  $S_{b2}$  turns on, the input voltage applied to the leakage inductance of transformer  $L_{Lk}$  increases the input current. The power in the primary side is transferred to the secondary side. The secondary voltage charges the capacitor  $C_h$  through the reverse-connected diode of auxiliary switch  $S_a$ . If the charging voltage is high enough to make the charging current zero, switch  $S_{b1}$  turns off. Switch  $S_{b3}$  turns on with zero-voltage scheme while the capacitor  $C_1$  is charged and the capacitor  $C_3$  is discharged. When auxiliary  $S_a$  turns on, the voltage across the auxiliary capacitor affects the primary voltage of the coupling transformer. This voltage is applied to the leakage inductance  $L_{Lk}$  with reverse polarity. This makes the primary current zero and switch  $S_{b2}$  turns off with zero-current scheme.

#### 4. Energy Storage Design

The size of super-capacitors is determined depending on the duration of voltage interruption and the size of load connected. It is assumed that the maximum voltage interruption has duration of three seconds and the load has a power rating of 10kW. Therefore, total energy to be released during the voltage interruption is 30 kJ.

The bank of super-capacitors is designed considering three criteria, the expandability of storage capacity, the unbalance of unit voltage, and the current rating of each unit. HP1700P-0027A manufactured by Ness Company was selected as a basic unit for the energy storage bank. Table 1 shows the specification of selected super-capacitor unit.

Table 1. Specification of super-capacitor unit

Parameters	Values
Capacitance	1700 F
Continuous operation voltage	2.7V
Peak operation voltage	2.85V
Current rating	360A

The bank is designed so as to utilize the upper 25% of maximum storage capacity, considering the expandability of operation capacity by adding more super-capacitors. The maximum current flows through the super-capacitor bank, when it discharges the maximum power. The minimum voltage across the super-capacitor bank can be determined with the

maximum discharge power and the current rating as the following.

$$U_{bank\_min} = 20kW / 360A = 55.5V \quad (1)$$

It is assumed that the super-capacitor is charged by 2.43V, which is 90% to the maximum charging voltage of 2.7V, for consideration of 10% margin. The lowest discharged voltage is determined to be 2.1V using the following.

$$U_{unit\_min} = \sqrt{3/4} U_{unit\_max} = 2.1V \quad (2)$$

Therefore, the lowest discharge voltage and the minimum unit voltage determine the number of units to be connected in series as the following.

$$N = U_{bank\_min} / U_{unit\_min} = 55.5 / 2.1 = 26.5 \quad (3)$$

However, the bank can be designed using total 28 units of super-capacitors for the purpose of safety margin.

Table 2. Grid parameters

Parameters	values
Source Phase Voltage ( <i>rms</i> )	220v / 50Hz
DC Link voltage	600v
Shunt inverter rating	45kVA
Series inverter rating	15kVA
Shunt inverter Inductance ( $L_f$ )	3mH
Shunt inverter Capacitance ( $C_f$ )	10 $\mu$ F
Switching Frequency	20kHz
Series inverter Inductance ( $L_s$ )	3mH
Series inverter Capacitance ( $C_s$ )	15 $\mu$ F
Series inverter Resistance ( $R_s$ )	12 $\Omega$
PV Array Rating	40kW

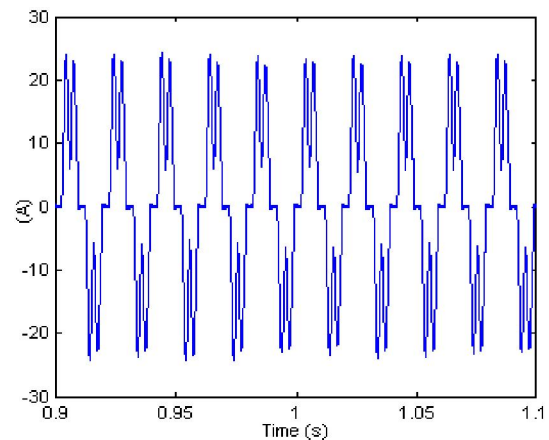

Figure 5. Nonlinear load current

#### 5. Simulation Results

The power circuit is modeled as a 3-phase 3-wire system with a non-linear load that is composed of 3-phase diode-bridge with RC load in the DC side with

a THD of more than 40%. The circuit parameters used in the simulation is shown in Table 2. The maximum simulation time was set up by 1.5sec. It is assumed that the shunt inverter start to operate at 100 msec, while the series inverter start to operate at 200 msec.

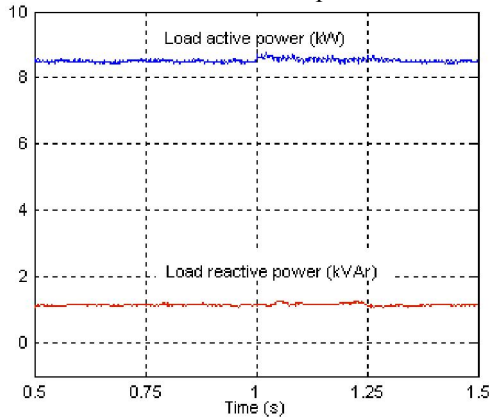

Figure 6. Active and reactive power consumed by load

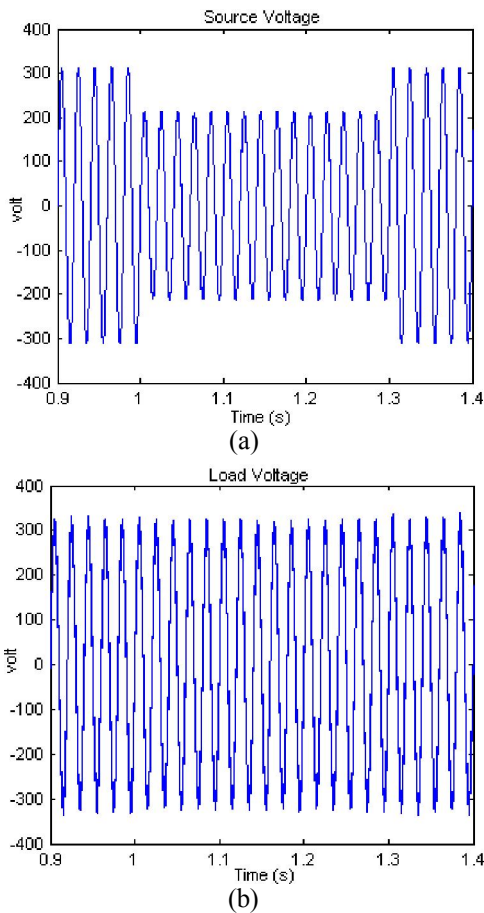

Fig. 7. Voltage sag compensation. (a) Source voltage. (b) Load voltage

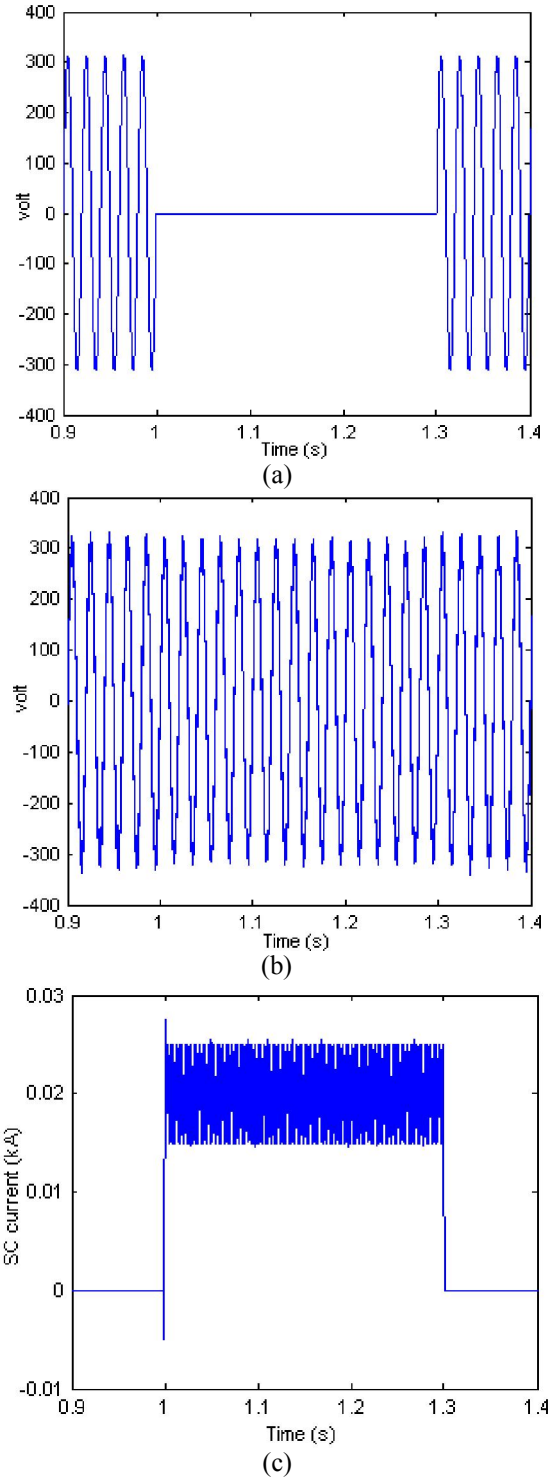

Fig. 8. Voltage interruption compensation. (a) Source Voltage. (b) Load voltage

The load current is shown in fig. 5. In fig. 6 the active and reactive power consumed by the load are demonstrated.

In next section, voltage sag is applied and the results are studied. A voltage sag with peak amplitude

of 100v is applied from  $t=1\text{sec}$  to  $t=1.3\text{sec}$ . The source and load voltage are shown in fig. 7. It is seen in this figure that the UPQC series inverter has modified load voltage correctly.

In this section, voltage interruption occurs from  $t=1\text{sec}$  to  $t=1.3\text{sec}$ . Fig. 8 shows the source and load voltage and the output current supplied by the DC/DC converter respectively. It is seen that after voltage interruption, load voltage is remained at its desired value due to shunt inverter operation.

## 6. Conclusions

This paper proposes a new configuration of UPQC that consists of the DC/DC converter and the super-capacitors for compensating the voltage interruption. The proposed UPQC can compensate the reactive power, harmonic current, voltage sag and swell, voltage unbalance, and the voltage interruption. The control strategy for the proposed UPQC was derived based on the Synchronous reference frame method. The operation of proposed system was verified through simulations with MATLAB/SIMULINK software. The proposed UPQC has the ultimate capability of improving the power quality at the installation point in the distribution system. The proposed system can replace the UPS, which is effective for the long duration of voltage interruption, because the long duration of voltage interruption is very rare in the present power system.

### Corresponding Author:

Yaser Hoseynpoor  
Roudehen Branch, Islamic Azad University,  
Roudehen, Iran  
E-mail: [yaser.hoseynpoor@gmail.com](mailto:yaser.hoseynpoor@gmail.com)

### References

- Hingorani N.G., Introducing custom power. IEEE Spectrum, 1995: 32,(6): 41- 48.
- Arrillaga J., Bollen M.H.J., Watson N.R., Power quality following deregulation. Proceedings of the IEEE, 2000: 88(2): pp. 246-261.
- Prodanovic M., Green T.C., Control and filter design of three-phase inverters for high power quality grid connection. IEEE Transactions on Power Delivery, 2003: 18(1): 373-380.
- Elkhodary S. M., Khafagy M., Application of Proposed Distribution Network Planning Rules on Fast Developing Countries, Journal of American science, 2010: 6(2): 327-335.
- Sedraoui K., Fnaiech F., Al-Haddad K., Solutions for Power Quality Using the Advanced UPFC - Control Strategy and Case Study, International Review of Electrical Engineering (IREE), 2008: 3(5): 811-819.
- Akagi H., Kanazawa Y., Nabae A.. Instantaneous reactive power compensator comprising switching devices without energy storage components. IEEE Transactions on Industry Application, 2007: 20: 625-630.
- Aredes M., Watanabe E.H., New control algorithms for series and shunt three-phase four-wire active power Filters. IEEE Transactions on Power Delivery, 1995: 10: 1649-1656.
- Han B., Bae B., Kim H., Baek S., Combined Operation of Unified Power Quality Conditioner With Distributed Generation. IEEE Transactions on Power Delivery, 2006: 21: 330-338.
- Hideaki F., Hirofumi A., The unified power quality conditioner: the integration of series- and shunt- active filters. IEEE Transactions on Power Electronics, 1998, 13(2): 315-322.
- Aredes M., Heumann K., Watanabe E.H., An universal active power line conditioner, IEEE Transactions on Power Delivery, 1998: 13(2): 545-551.
- Hu M., Chen H., Modeling and Controlling of Unified Power Quality Compensator. IEEE International Conference on Advances in Power System Control, Operation and Management, 2000: 2: 431-435.
- Bendre A., Norris S., Divan D., Wallace I., New high power DC/DC converter with loss limited switching and lossless secondary clamp. IEEE Transactions on Power Electronics, 2003: 18(4): 1020-1027.
- Jacobs J., Averberg A., De Doncker R., A novel three-phase DC/DC converter for high-power applications. IEEE Power Electronics Specialists Conference, 2004: 3: 1861-1867.

3/25/2017