

Modeling and Application of PV Systems Interconnection to Grid through the DC Link of UPQC

F. Gharedaghi, M. Deysi, H. Jamali, A khalili

Dashtestan Branch, Islamic Azad University, Borazjan, Iran

Fariba.gharedaghi@yahoo.com

Abstract: This paper presents a simulation model of the electric part of a grid connected photovoltaic generator. The proposed system consists of a series inverter, a shunt inverter, and some photovoltaic arrays connected in the dc link through the DC-DC converter. A numerical formulation of the proposed control schemes, which are based on the instantaneous power theory, is presented. The proposed system is able to inject the active power to grid in addition to its ability in improvement of power quality in point of common coupling. Also it can provide a part of sensitive load power during voltage interruption. The results of simulation in MATLAB/SIMULINK software show that the mentioned system operates correctly.

[F. Gharedaghi, M. Deysi, H. Jamali, A khalili. **Modeling and Application of PV Systems Interconnection to Grid through the DC Link of UPQC.** *Academ Arena* 2017;9(6):94-102]. ISSN 1553-992X (print); ISSN 2158-771X (online). <http://www.sciencepub.net/academia>. 13. doi:[10.7537/marsaaj090617.13](https://doi.org/10.7537/marsaaj090617.13).

Keywords: Unified power quality conditioner (UPQC), Photovoltaic array (PV), Interconnected mode, Islanding mode, Maximum power point tracking (MPPT)

1. Introduction

One of the comparative structures of the electric power is back to back converter. In respect to controlling structure, these converters may have various operations in compensation. For example, they can operate as series or shunt active filters for synchronous compensating the load current harmonics and voltage oscillation [1]. This is called unified power quality conditioner (UPQC) [2].

UPQC is greatly studied by several researchers as a basic device to control the power quality [3-7]. The duty of UPQC is reducing perturbations which affect on the operation of sensitive loads. UPQC is able to compensate voltage sag and swell, voltage and current harmonics using shunt and series inverters. In spite of this issue, UPQC is not able to compensate voltage interruption and active power injection to grid, because in its DC link, there is no energy source.

The attention to distributed generating (DG) sources is increasing day by day. The reason is their important roll they will likely play in the future of power systems [8]. Recently, several studies are accomplished in the field of connecting DGs to grid using power electronic converters. Here, grid's interface shunt inverters are considered more where the reason is low sensitiveness of DGs to grid's parameters and DG power transferring facility using this approach. Although DG needs more controls to reduce the problems like grid power quality and reliability, PV energy is one of the distributed generation sources which provides a part of human required energy nowadays and will provide in the future. The greatest share of applying this kind of energy in the future will be its usage in interconnected systems. Nowadays, European countries, has caused

interconnected systems development in their countries by choosing supporting policies [9]. In this paper, UPQC and PV combined system has been presented. UPQC introduced in [10] has the ability to compensate voltage sag and swell, harmonics and reactive power.

In fig. 1 the general structure of grid connected PV systems is shown. The advantage of proposed combined system is voltage interruption compensation and active power injection to grid in addition to the mentioned abilities. Also, this proposed system has higher efficiency and functioning ability in compare with other common PVs and causes reduction in system's total cost. Simulation results, using (PSCAD/EMTDC) software show that this proposed system operates correctly.

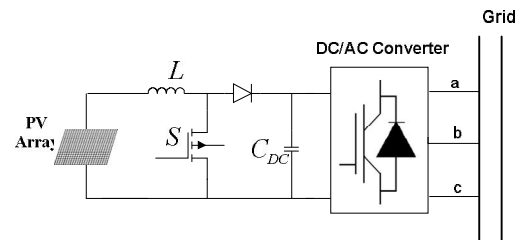

Fig. 1. General structure of grid connected PV systems

2. Materials and Methods

UPQC has two shunt and series voltage source inverters which are as 3-phase 3-wire or 3-phase 4-wire. Shunt inverter is connected to point of common coupling (PCC) by shunt transformer and series inverter stands between source and coupling point by

series transformer. Shunt inverter operates as current source and series inverter operates as voltage source.

UPQC is able to compensate current's harmonics, to compensate reactive power, voltage distortions and control load flow but cannot compensate voltage interruption because of not having any sources.

Common interconnected PV systems structure is as fig. 1 which is composed of PV array, DC/DC and DC/AC converters.

In this paper a new structure is proposed for UPQC, where PV is connected to DC link in UPQC as energy source. In this case, UPQC finds the ability of injecting power using PV to sensitive load during source voltage interruption. Fig. 2 shows the configuration of proposed system. In this proposed system, two operational modes are studied as follow:

A. Interconnected mode; where PV transfers power to load and source.

B. Islanding mode; where the source voltage is interrupted and PV provides a part of load power separately.

Controller Designing

The controlling structure of proposed system is composed of three following parts:

- A. Shunt inverter control
- B. Series inverter control
- C. DC/DC converter

Controlling strategy is designed and applied for two interconnected and islanding modes. In interconnected mode, source and PV provide the load power together while in islanding mode; PV transfers the power to the load lonely. By removing voltage interruption, system returns to interconnected mode.

2.1. Shunt inverter control

In this paper, shunt inverter undertakes two main duties. First is compensating both current harmonics generated by nonlinear load and reactive power, second is injecting active power generated by PV system. The shunt inverter controlling system should be designed in a way that it would provide the ability of undertaking two above duties. Shunt inverter control calculates the compensation current for current harmonics and reactive power when PV is out of the grid. The power loss caused by inverter operation should be considered in this calculation. Also, shunt inverter control undertakes the duty of (stabilizing) DC link voltage during series inverter operation to compensate voltage distortions. DC link capacitor voltage controlling loop is used here by applying PI controller. Fig. 3 shows the circuit block diagram of shunt inverter controlling.

2.1.1. Shunt inverter control in interconnected mode

Mode (1) of fig. 3 shows UPQC shunt voltage source inverter controlling block diagram applying

synchronous reference frame theory method where sensitive load currents are I_{la} , I_{lb} and I_{lc} .

Measured load currents applying synchronous reference frame conversion method (dq0), are transferred to dq0 frame using sinusoidal functions. Sinusoidal functions are obtained by PLL using grid voltage. Currents in this synchronous reference are decomposed to two dc and ac (50 Hz) quantities (using \sim sign above the parameter).

$$I_{ldq0} = T_{abc}^{dq0} I_{abc} \quad (1)$$

$$T_{abc}^{dq0} = \frac{2}{3} \begin{bmatrix} \cos \theta & \cos\left(\theta - \frac{2\pi}{3}\right) & \cos\left(\theta + \frac{2\pi}{3}\right) \\ \sin(\theta) & \sin\left(\theta - \frac{2\pi}{3}\right) & \sin\left(\theta - \frac{2\pi}{3}\right) \\ \frac{1}{2} & \frac{1}{2} & \frac{1}{2} \end{bmatrix} \quad (2)$$

$$I_{ld} = \bar{I}_{ld} + \tilde{I}_{ld}, \quad I_{lq} = \bar{I}_{lq} + \tilde{I}_{lq} \quad (3)$$

where I_d is active and I_q is reactive part of power. AC and DC elements can be extracted by a low pass filter.

In this case:

$$I_l = I_s + I_c \quad (4)$$

In relation (4) I_s is the source current, I_l is the load current and I_c is the compensating current injected by shunt inverter. If compensation reference currents are considered as follow:

$$I_{fd}^* = \tilde{I}_{ld}, \quad I_{fq}^* = \tilde{I}_{lq} \quad (5)$$

In this case, the system's currents are:

$$I_{sd} = \bar{I}_{ld}, \quad I_{sq} = \bar{I}_{lq} \quad (6)$$

In the above condition, just the load current harmonics are compensated. If power factor is considered too, the reference currents would be as follow:

$$I_{fd}^* = \tilde{I}_{ld}, \quad I_{fq}^* = I_{lq} \quad (7)$$

then system currents are:

$$I_{sd} = \bar{I}_{lq}, \quad I_{sq} = 0 \quad (8)$$

So no harmonic and reactive power will be provided by the source.

Switching losses and the power which the series inverter receives from capacitor, can reduce the

voltage average value of DC bus. Other distortions such as unbalanced and sudden load current variations can cause oscillation in DC bus voltage. In order to track the error exists between the measured and desired value of capacitor voltage, a PI controller is applied. This controlling signal is applied to current control system in shunt voltage source in a way that it control DC capacitor voltage by obtaining required

active power (I_d) from the grid. The output part of PI controller (Δi_{dc}), is added to the q part of reference current where the reference current would change as follow:

$$I_{cd}^* = \tilde{I}_{ld} + \Delta i_{dc}, I_{cq}^* = I_{lq} \tag{9}$$

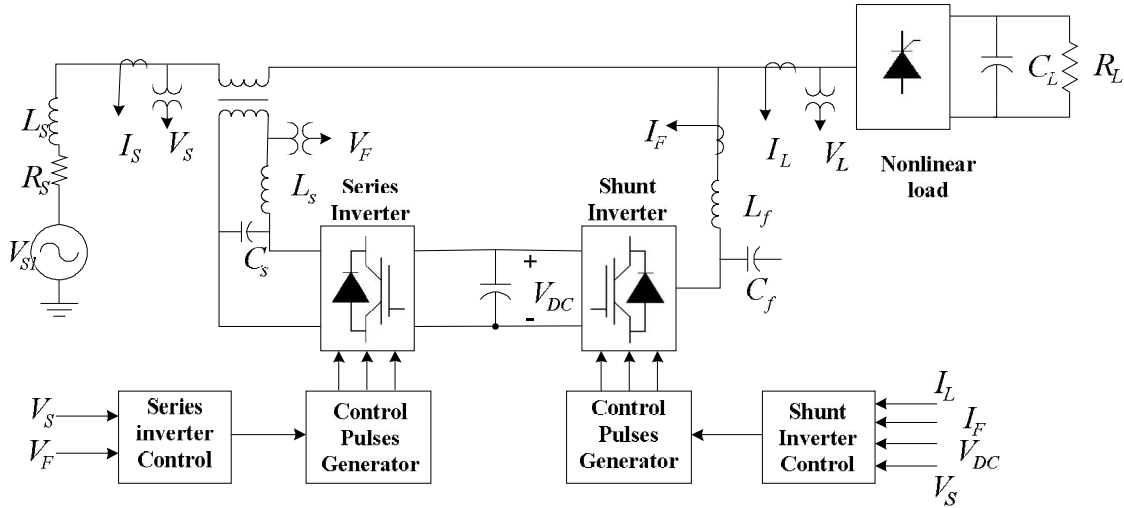

Figure 2. Configuration of proposed UPQC with PV

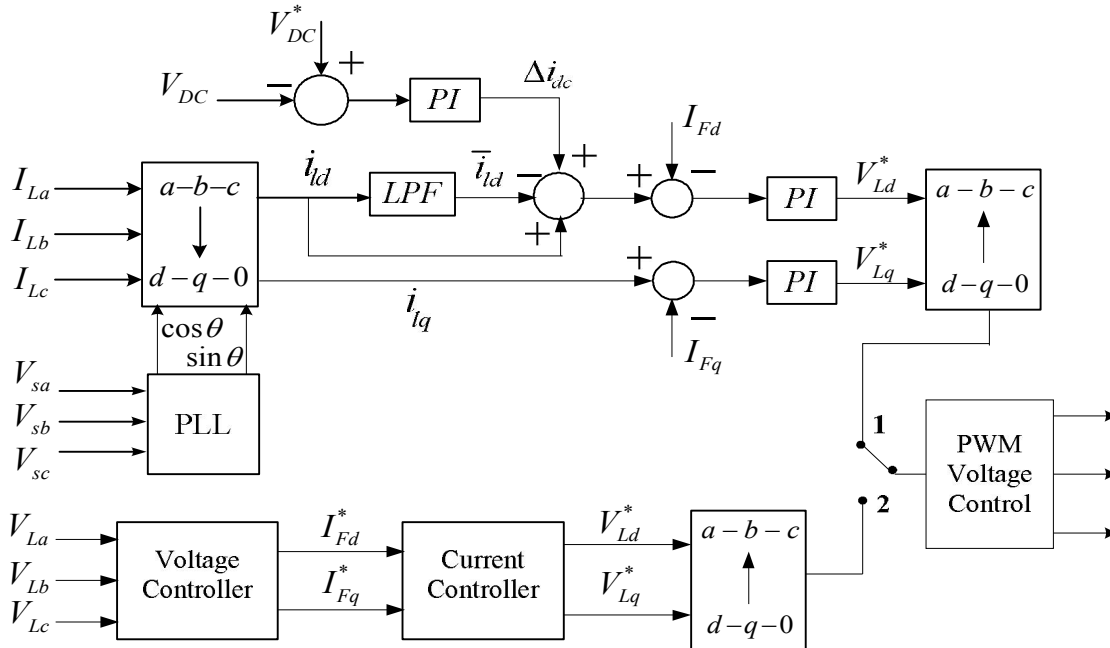

Figure 3. Control block diagram of shunt inverter

As it is shown in fig. 4, the reference currents will transfer to abc frame by reverse converting the synchronous reference frame, as relation (1). Resulted reference currents will be compared with shunt

inverter output currents (I_{fa}, I_{fb}, I_{fc}) in a PWM current controller (hysteresis type) and required controlling pulses are generated. Applying these

signals to shunt inverter power switches gate, required compensation current is generated by inverter.

In addition to previous duties, shunt inverter control should inject active power of PV system to the grid when PV is operating. Active power is injected to grid by capacitor voltage controlling loop. In other words, when voltage increases and reaches to the value which is more than the reference voltage value, shunt inverter injects active power to grid and when it decreases to value which is less than the reference voltage value; shunt inverter receives active power from the grid.

2.1.2. Shunt inverter control in islanding mode

If voltage interruption occurs, the shunt inverter's operation will switch from interconnected mode (mode 1) to islanding mode (mode 2). PV system provides required active power to stabilize load voltage. In this case, shunt inverter controls output voltage and current in order to inject to load using PI controller. Relations of shunt inverter control in this case, would be as follow [10]:

$$I_{fd}^* = K_{PI} (V_{Ld}^* - V_{Ld}) - \omega C_p V_{Lq} + I_{Ld} \quad (10)$$

$$I_{fd}^* = K_{PI} (V_{Ld}^* - V_{Ld}) - \omega C_p V_{Lq} + I_{Ld} \quad (11)$$

$$V_{Ld}^* = K_{PI} (I_{fd}^* - I_{fd}) - \omega L_f I_{fq} + V_{Ld} \quad (12)$$

$$V_{Lq}^* = K_{PI} (I_{fq}^* - I_{fq}) + \omega L_f I_{fd} + V_{Lq} \quad (13)$$

where V_{Ld} and V_{Lq} are shunt inverter voltage outputs in d and q axis. Fig. 4 shows the block diagram of shunt inverter control based on the above relations to control the shunt inverter during voltage interruption and islanding mode.

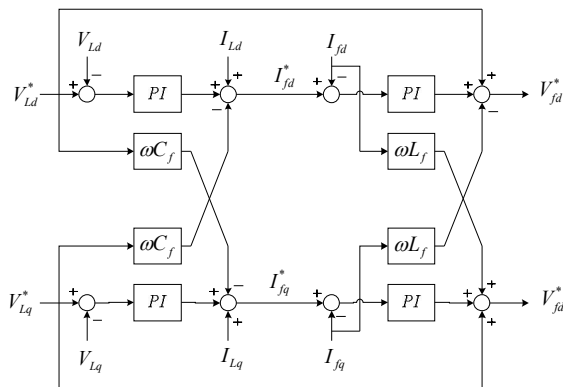

Figure 4. Controlling block diagram of shunt inverter in islanding mode

2.2. Series inverter controlling

The duty of series inverter is compensating voltage distortions which are caused by fault in distribution grid. Series inverter control calculates the voltage reference values which are injected to grid by series inverter.

In order to control series inverter of UPQC, load sinusoidal voltage controlling strategy is proposed. In this condition, UPQC series inverter would be controlled in a way that it compensates the whole distortions and helps the voltage of load voltage stay (balanced sinusoidal 3-phase). In order to reach this aim, synchronous reference frame theory is applied [10].

In this method the desired value of load phase voltage is replaced in d and q -axes instead of high pass and low pass filters. Load voltage should be completely a sinusoidal function and has constant frequency and amplitude. Desired voltage of load is as relation (14):

$$V_{ldq0}^* = T_{abc}^{dq0} V_{labc}^* = \begin{bmatrix} V_m \\ 0 \\ 0 \end{bmatrix} \quad (14)$$

in this relation V_{labc}^* is:

$$V_{labc}^* = \begin{bmatrix} V_m \cos(\omega t + \theta) \\ V_m \cos(\omega t + \theta - 120^\circ) \\ V_m \cos(\omega t + \theta + 120^\circ) \end{bmatrix} \quad (15)$$

where V_m is desired peak value of load voltage and (θ) is voltage phase angle which is calculated by phase locked loop (PLL). By subtracting the desired

value of d-axis phase voltage (V_{ld}^*) from V_{sd} , all distortions in d-axis are obtained. Also, the desired value of load phase voltage in q-axis is zero. In other

words, V_{sq} represents total q-axis distortions. So series compensation reference voltage is resulted by relation (16):

$$V_{fdq0}^* = V_{ldq0}^* - V_{sdq0} \quad (16)$$

These voltages are compared with an angular waveform in PWM controller and required controlling pulses (g_1, \dots, g_6) are generated to be applied to series voltage source inverter switches.

This corrected method is programmable with a low cost. The other advantage is that the controlling system's calculation time is shortened and so

controlling system's response is faster. Fig. 5 shows the block diagram of series compensator's controlling circuit applying synchronous reference frame method. In order to improve series inverter operation, SPWM method is used where the resulted value of subtracting

V_{fab}^* from V_{fab} is multiplied to a constant coefficient and the obtained value is added to V_{fab}^* . Applying this method distinctively improves operation of series inverter.

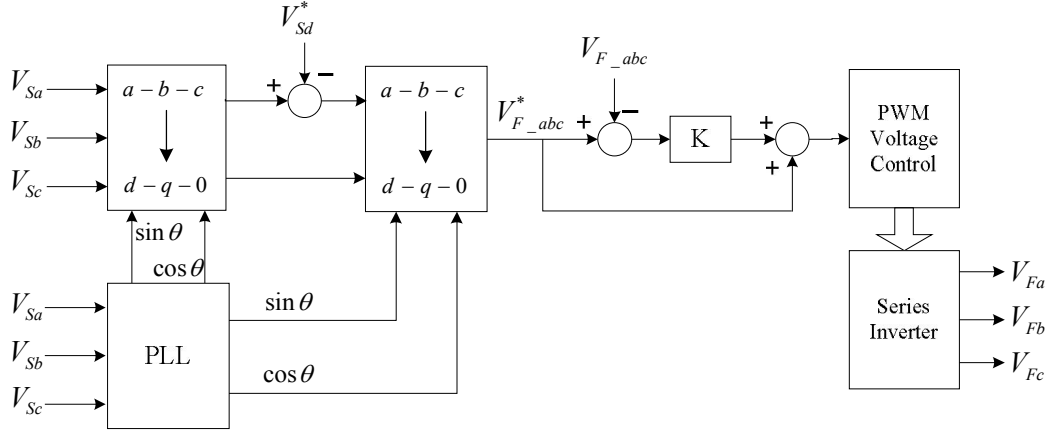

Figure 5. Control block diagram of series inverter

2.3. DC/DC converter controlling to obtain the maximum power of PV array

PV systems are nonlinear power sources whose output power is greatly under effect of two radiation and environment temperature elements. One of the disadvantages of these systems is their low efficiency, because solar cells rarely operate at their maximum power point. So in order to increase the efficiency, as much power as possible should be extracted from the array. Temperature variation effects on cell voltage and radiation variation effects on cell current. Fig. 6 shows the equivalent circuit of PV array used in simulation.

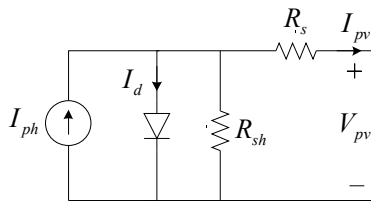

Figure 6. Equivalent circuit of PV array

In connection of the PV array to grid, a DC/DC converter is applied and is used to adapt the variable voltage of PV with the voltage of grid and extract the maximum power from the array. In respect to Fig. 7 MPPT is obtained by controlling the duty cycle of DC/DC converter switch.

Some methods of finding optimum operation point of solar array are as follow:

1. Mathematically solving the voltage-power equation of solar cell.

2. Algorithm of perturbation and observation (P & O).
3. Incremental conduction method (Inc Con).
4. Maximum power point forecasting based on the current method.
5. Maximum power point forecasting based on the voltage method.

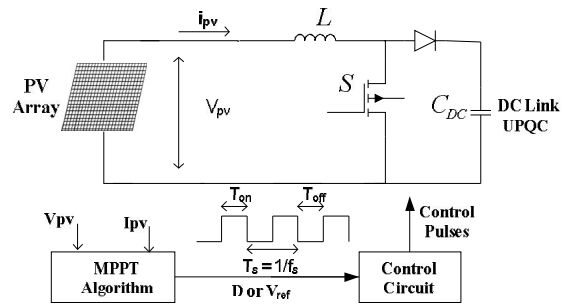

Figure 7. Schematic block diagram of MPPT of PV array

In this paper, P & O method is used to achieve the maximum power point. P & O method is one of the most common methods applied to achieve the maximum power point. In P & O method, a short perturbation is created in array's output voltage and then output voltage is measured. If this perturbation causes an increase in output power, then the next perturbation will be applied in this direction, and if it causes reduction, then voltage perturbation will be applied in reverse direction and this process continues till achieving the maximum power point of the array.

The advantage of P & O method is its simple application and its disadvantage is its capability to determine the correct MPP during sudden and fast variation in environmental conditions. Of course, the probability of sudden variations in environmental conditions is very low.

As it is seen in fig. 7, the duty cycle of converter switch is determined by measuring voltage and array's current values in specific periods of time and applying maximum power tracking algorithm.

4. Simulation

In simulation part, power system is modeled as a 3-wired 3-phase system by an RC load with uncontrolled diode rectifier. The PV model applied in simulation is as fig. 6 whose parameters are regulated for normal condition (25°C temp & sun radiation) Circuit parameters used in simulation are located in table 1. The maximum simulation time is regulated on 600msec. Shunt inverter starts to operate at 100msec and series inverter starts at 200msec.

Table 1. Grid Parameters

Components	values
Source Phase Voltage (<i>rms</i>)	220v / 50Hz
DC Link voltage	600v
Shunt inverter rating	45kVA
Series inverter rating	15kVA
Shunt inverter Inductance (L_f)	3mH
Shunt inverter Capacitance (C_f)	10 μF
Switching Frequency	20kHz
Series inverter Inductance (L_s)	3mH
Series inverter Capacitance (C_s)	15 μF
Series inverter Resistance (R_s)	12 Ω
PV Array Rating	40kW

Nonlinear load's current is illustrated in fig. 8. Active and reactive powers consumed by load are shown in fig. 9. Simulated load consumes 17kW active power and 8kVar reactive power.

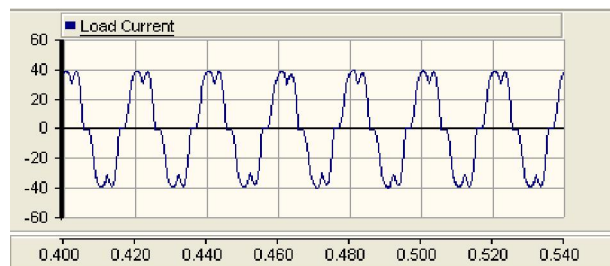

Fig. 8. Nonlinear load's current

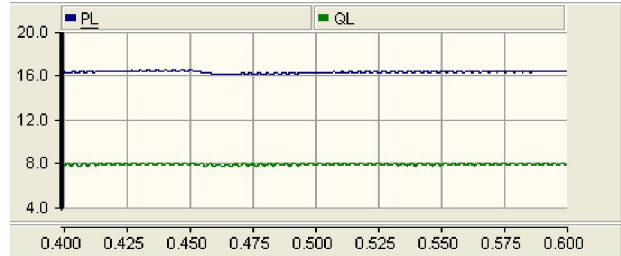

Fig. 9. Active and reactive power consumed by nonlinear load

In this part of simulation, it is assumed that the PV array is interconnected to grid and outages after 0.45s of operation. The current, injected by shunt inverter is shown in fig. 10. As it is shown in fig. 10 at the presence of PV, shunt branch injects a high current to grid, a part of which is consumed to feed the load and else is injected to grid. When PV outages, the shunt branch undertakes the duty of compensating current harmonics and current's reactive power.

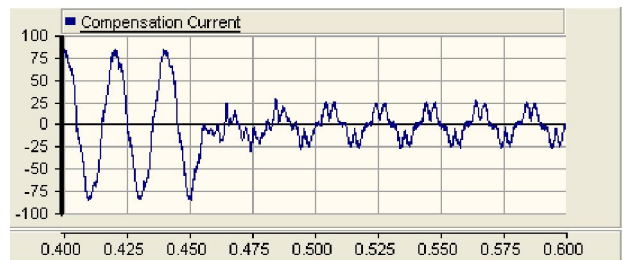

Fig. 10. Current of shunt inverter injected to grid

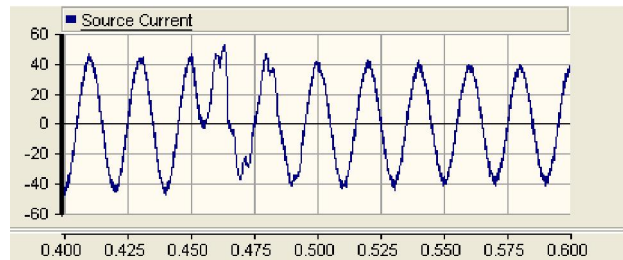

Fig. 11. source current

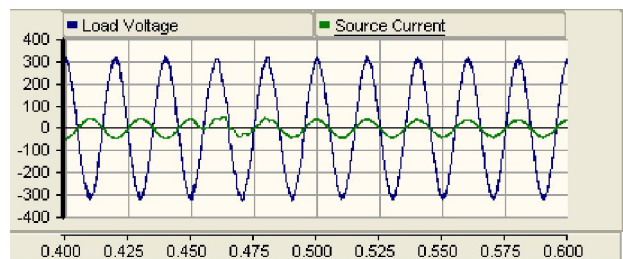

Fig. 12. source current and voltage

Fig. 11 shows the source current and fig. 12 presents the source voltage. At 0.45sec when PV outages, source current returns to sinusoidal mode

after passing the transient state. With respect to fig. 12 it can be understood that, before PV outages, voltage has 180° phase difference with its current and PV injects current to source in addition to providing load. After PV outages, it is seen that, voltage and current are in same phase and UPQC compensates current harmonics and power factor.

Fig. 13 shows the total harmonic distortions (THD) of source and load currents. Shunt inverter has been able to make current's wave form sinusoidal and reduce the THD of load current from 22% to 3%.

In fig. 14 active and reactive powers injected by shunt inverter are shown. When PV outages, injective reactive power doesn't vary distinctively, while injective active power decreases to a negative value from 37.5kW. In other words, shunt inverter, is not able to inject active power after PV outages and required active power of series inverter is provided through shunt inverter from the grid.

DC link voltage is shown in fig. 15 for the above cases. When PV outages, the voltage of DC link decreases and returns to its desired value by correct operation of DC controlling loop.

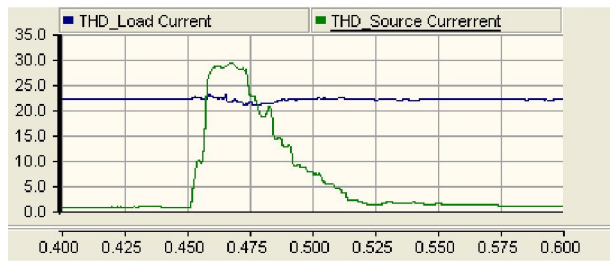

Fig. 13. Load and source current THD

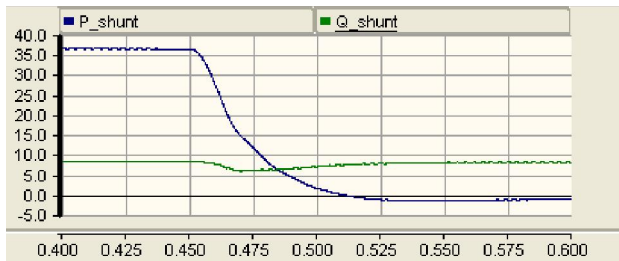

Fig. 14. Active and reactive power injected by shunt inverter

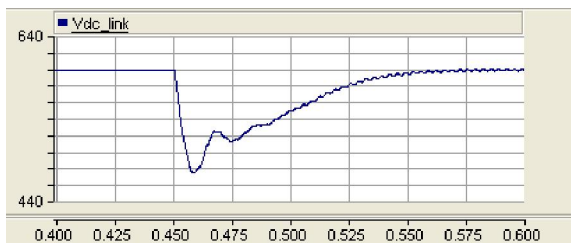

Fig. 15. DC link voltage

In this part of simulation, by applying voltage sag to the grid side, series inverter's operation is studied to improve voltage sag and it is investigated that how series and shunt inverters inject power to the grid at the presence of PV.

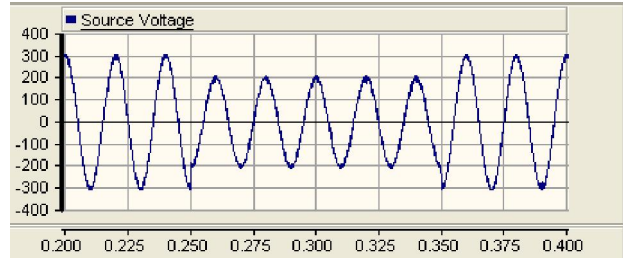

Fig. 16. voltage sag in source voltage

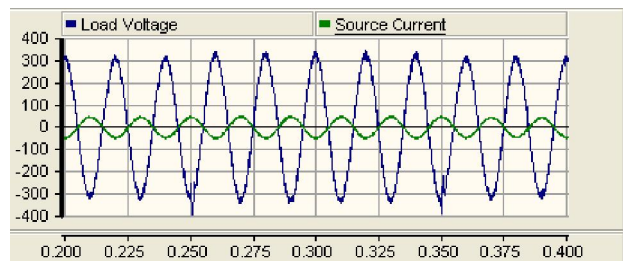

Fig. 17. load voltage and source current

In Fig 16 source side voltage in which voltage sag has occurred during 0.25 to 0.35 seconds is shown.

Fig. 17 shows the load side voltage and source current. Load voltage is completely compensated and current has 180° phase difference with load voltage. This issue shows the complete compensation of load's reactive power too.

The voltage injected by series inverter to compensate the voltage sag is shown in fig. 18.

The active power injected by series and shunt inverters during voltage sag occurrence is shown in fig. 19. When voltage sag occurred, share of series inverter in PV's active power transferring and voltage sag compensation increases and a part of active power injected by series inverter decreases.

In the third part of simulation, voltage interruption is applied in the source and the operation of PV system in providing the power which is required by load is studied. In order to do this, a voltage interruption occurs at 0.5 seconds and immediately the power switches parallel with series transformer are closed and so other switches allocated between shunt and series inverters are opened and so isolate shunt inverter from the grid. Controlling algorithm of parallel inverter, switches from interconnected mode to islanding mode.

In fig. 20 the source side voltage is shown during voltage interruption occurrence. Fig. 21 shows load

current. When interruption occurs, load current is provided by shunt inverter and PV. The active power injected by shunt inverter to load is shown in fig. 22. As it is seen, during interruption occurrence, the power injected by PV is the function of the load's required power in PV power range off course.

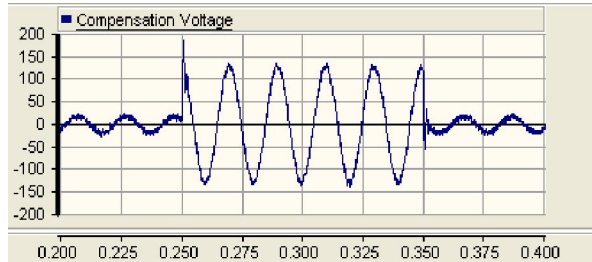

Fig. 18. voltage injection by series inverter

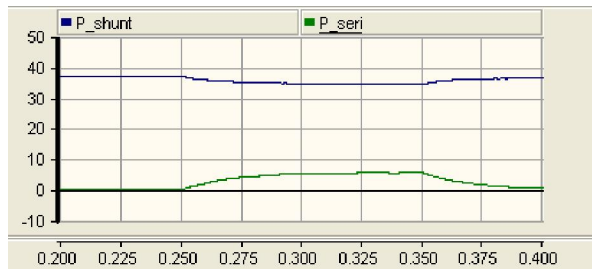

Fig. 19. Active power injected by series and shunt inverters

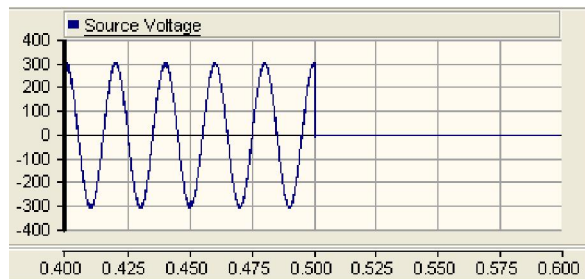

Fig. 20. voltage interruption in source voltage

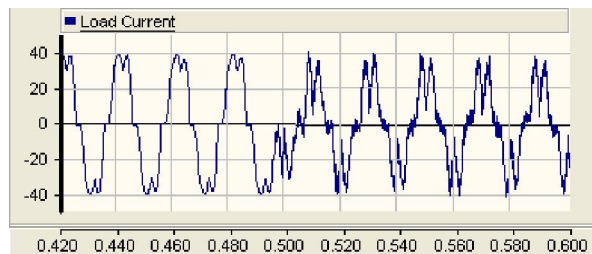

Fig. 21. load current during voltage interruption occurrence

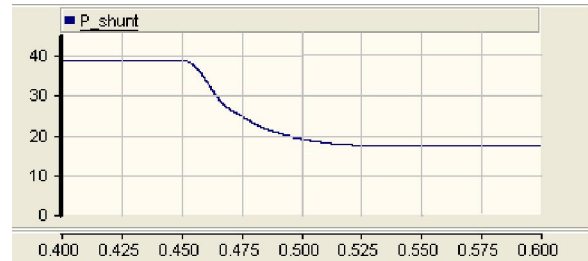

Fig. 22. active power injected by shunt inverter to load

5. Conclusion

In this paper, the results of analyzing combined operation of UPQC and PV is explained. The proposed system is composed of series and shunt inverters, PV array and DC/DC converter which can compensate the voltage sag, swell, interruption and reactive power and harmonics in both islanding and interconnected modes.

The advantages of proposed system is reducing the expense of PV interface inverter connection to grid because of applying UPQC shunt inverter and also is the ability of compensating the voltage interruption using UPQC because of connecting PV to DC link. In this proposed system, P & O method is used to achieve the maximum power point of PV array. This proposed system's operation is analyzed using (PSCAD/EMTDC) software and simulation results confirm that the proposed system operates correctly.

Corresponding Author:

Fariba Gheradaghi
Dashtestan Branch, Islamic Azad University,
Borazjan, Iran
E-mail: Fariba.gharedaghi@yahoo.com

References

1. Akagi H., Kanazawa Y., Nabae A., Instantaneous reactive power compensator comprising switching devices without energy storage components, *IEEE Trans. Industry Application*, 1984; 20(30): 625-630.
2. Aredes M., Watanabe E.H., New control algorithms for series and shunt three-phase four-wire active power Filters. *IEEE Transactions on Power Delivery*, 1995; 10: 1649-1656.
3. Akagi H., Fujita H., A new power line conditional for harmonic compensation in power systems, *IEEE Trans. Power Del.*, 1995; 10(3): 1570-1575.
4. Elkhodary S. M., Khafagy M., Application of Proposed Distribution Network Planning Rules on Fast Developing Countries, *Journal of American science*, 2010; 6(2): 327-335.

5. Fujita H. and Akagi H., The unified power quality conditioner: The integration of series and shunt-active filters, *IEEE Trans. Power Electron.*, 1998: 13(2): 315–322.
6. Chen Y., Zha X., Wang J., Unified power quality conditioner (UPQC): The theory, modeling and application, *Proc. Power System Technology Power Con Int. Conf.*, 2000: 3: 1329–1333.
7. Peng F.Z., McKeever J.W, Adams D.J., A power line conditioner using cascade multilevel inverters for distribution systems, *IEEE Transactions on Industry Applications*, 1998: 34(6): 1293–1298.
8. Barker P.P., de Mello R.W., Determining the impact of distributed generation on power systems: Part1-Radial distribution systems, *IEEE Conference on Power Engineering Society Summer Meeting*, 2000: 3: 1645–1656.
9. Watanabe H., Shimizu T., Kimura G., A novel utility interactive photovoltaic inverter with generation control circuit, *IEEE conference on Industrial Electronics Society*, 1998: 3: 721-725.
10. B. Han, B. Bae, H. Kim, S. Baek, Combined Operation of Unified Power-Quality Conditioner With Distributed Generation, *IEEE Transactions on Power Delivery*, 2006: 21: 330-338.

6/22/2017