

The Journal of American Science

ISSN 1545-1003

Volume 5 - Number 1 (Cumulated No. 16), January 1, 2009



Marsland Press, Michigan, The United States

<http://www.americanscience.org>

editor@americanscience.org

Journal of American Science

The *Journal of American Science* is an international journal with a purpose to enhance our natural and scientific knowledge dissemination in the world under the free publication principle. Any valuable paper that describes natural phenomena and existence or any report that conveys scientific research and pursuit are welcome, including both natural and social sciences. Papers submitted could be reviews, objective descriptions, research reports, opinions/debates, news, letters, and other types of writings that are nature and science related. The journal is calling for papers and seeking co-operators and editors as well.

Editor-in-Chief: Hongbao Ma

Associate Editors-in-Chief: Shen Cherng, Jingjing Z Edmondson, Qiang Fu, Yongsheng Ma

Editors: George Chen, Mark Hansen, Mary Herbert, Deng-Nan Horng, Wayne Jiang, Mark Lindley, Margaret D. Ma, Mike Ma, Da Ouyang, Xiaofeng Ren, Ajaya Kumar Sahoo, Shufang Shi, Tracy X Qiao, Pankaj Sah, George Warren, Qing Xia, Yonggang Xie, Lijian Yang, Jenny Young, Tina Zhang, Ruanbao Zhou, Yi Zhu

Web Design: Jenny Young

Introductions to Authors

1. General Information

(1) Goals: As an international journal published both in print and on internet, the *Journal of American Science* is dedicated to the dissemination of fundamental knowledge in all areas of nature and science. The main purpose of the *Journal of American Science* is to enhance our knowledge spreading in the world under the free publication principle. It publishes full-length papers (original contributions), reviews, rapid communications, and any debates and opinions in all the fields of nature and science.

(2) What to Do: The *Journal of American Science* provides a place for discussion of scientific news, research, theory, philosophy, profession and technology - that will drive scientific progress. Research reports and regular manuscripts that contain new and significant information of general interest are welcome.

(3) Who: All people are welcome to submit manuscripts in any fields of nature and science.

(4) Distributions: Web version of the journal is freely opened to the world, without any payment or registration. The journal will be distributed to the selected libraries and institutions for free. For the subscription of other readers please contact with: editor@americanscience.org or americansciencej@gmail.com or editor@sciencepub.net

(5) Advertisements: The price will be calculated as US\$400/page, i.e. US\$200/a half page, US\$100/a quarter page, etc. Any size of the advertisement is welcome.

2. Manuscripts Submission

(1) Submission Methods: Electronic submission through email is encouraged and hard copies plus an IBM formatted computer diskette would also be accepted.

(2) Software: The Microsoft Word file will be preferred.

(3) Font: Normal, Times New Roman, 10 pt, single space.

(4) Indent: Type 4 spaces in the beginning of each new paragraph.

(5) Manuscript: Don't use "Footnote" or "Header and Footer".

(6) Cover Page: Put detail information of authors and a short title in the cover page.

(7) Title: Use Title Case in the title and subtitles, e.g. "Debt and Agency Costs".

(8) Figures and Tables: Use full word of figure and table, e.g. "Figure 1. Annual Income of Different Groups", Table 1. Annual Increase of Investment".

(9) References: Cite references by "last name, year", e.g. "(Smith, 2003)". References should include all the authors' last names and initials, title, journal, year, volume, issue, and pages etc.

Reference Examples:

Journal Article: Hacker J, Hentschel U, Dobrindt U. Prokaryotic chromosomes and disease. *Science* 2003;301(34):790-3.

Book: Berkowitz BA, Katzung BG. Basic and clinical evaluation of new drugs. In: Katzung BG, ed. Basic and clinical pharmacology. Appleton & Lance Publisher. Norwalk, Connecticut, USA. 1995:60-9.

(10) Submission Address: editor@sciencepub.net, Marsland Press, P.O. Box 21126, Lansing, Michigan 48909, The United States, 517-349-2362.

(11) Reviewers: Authors are encouraged to suggest 2-8 competent reviewers with their name and email.

2. Manuscript Preparation

Each manuscript is suggested to include the following components but authors can do their own ways:

(1) Title page: including the complete article title; each author's full name; institution(s) with which each author is affiliated, with city, state/province, zip code, and country; and the name, complete mailing address, telephone number, facsimile number (if available), and e-mail address for all correspondence.

(2) Abstract: including Background, Materials and Methods, Results, and Discussions.

(3) Key Words.

(4) Introduction.

(5) Materials and Methods.

(6) Results.

(7) Discussions.

(8) Acknowledgments.

(9) Correspondence to.

(10) Submission date

(11) References.

Journal Address:

Marsland Press
2158 Butternut Drive
Okemos, MI 48864
The United States
Telephone: (517) 349-2362
E-mail: editor@americanscience.org;
editor@sciencepub.net;
americansciencej@gmail.com
Websites: <http://www.americanscience.org>;
<http://www.sciencepub.org>

The Journal of American Science
Volume 5 - Number 1, January 10, 2009, ISSN 1545-1003

Contents

1. Plant Diversity of a Fresh Water Swamp of Doon Valley, India.
Manhas R.K., Mukesh Kumar Gautam and Deepa Kumari 1-7
2. Histological Interactions Of Paecilomyces Lilacinus And Meloidogyne Incognita
On Bitter Gourd Mohd Yaqub Bhat, Hissamuddin, Nazir Ahmad Bhat 8-12
3. Experimental Study on The Dynamic Behaviors of the Material for Clay core wall sand dams
Xu Shangjie, Dang Faning, Tian Wei, Cheng Mo 13-18
4. Influence of Subchronic Exposure of Profenofos on Biochemical
Markers and Microelements in Testicular Tissue of Rats
Afaf A. El-Kashoury 19-28
5. Effect of Duckweed meal on the rate of mold infestation in stored pelleted fish feed.
B.N. Effiong, A. Sanni 29-34
6. Distribution and Sources of Organochlorine Pesticides (OCPs)
in Karst Cave, Guilin, China
Annette Sylvie Muhayimana, Qi Shihua, Wang Yinghui 35-43
7. An Incidence of Substratum Discolouration in a Tropical West African Lagoon.
Onyema, I.C. and Nwankwo, D.I. 44-48
8. The Influences of Extremely Low Frequency AC Magnetic Fields
At 60Hz on Mung Beans Growth
Pai-Tsun Tien and Show-Ran Wang 49-54
9. The Inflation Dynamics of the ASEAN-4: A Case Study of the Phillips Curve Relationship
Klarizze Anne M. Puzon 55-57
10. Estimating Soil Loss Using Universal Soil Loss Equation (USLE)
for Soil Conservation planning at Medego Watershed, Northern Ethiopia
Gebreyesus Brhane and Kirubel Mekonen 58-69
11. Conservation through *in vitro* method: A case of plant regeneration
through somatic embryogenesis in *Quercus semecarpifolia* Sm.
Sushma Tamta, Lok Man S. Palni, P. Vyas and M.S. Bisht 70-76
12. Synthesis, characterization and Electroluminescence of
BPh₂(2-(benzimidazol-2-yl) pyridinato) compound
Anchi Yeh 77-82
13. White Organic Electroluminescence Base on a new Aluminum Complex
Anchi Yeh, Hsien-Chiao Teng 83-87

Plant Diversity of a Fresh Water Swamp of Doon Valley, India.

¹Manhas, R.K., ²Mukesh Kumar Gautam and ³Deepa Kumari

¹Department of Botany, S.P. College, Srinagar- 190 001 (J and K)

²Forest Ecology and Environment Division, Forest Research Institute, D.Dun- 248 006 (UA)

³Cosmic Hearts Higher Secondary School, Kathua- 184 101 (J and K)

ABSTRACT: The present study was conducted in a highly degraded and fragmented swamp of Doon valley, India. A total of 162 plant species were recorded from the swamp. Dicotyledons contributed 71%, monocotyledons 23.5% and pteridophytes 5.6%. Poaceae with 15 genera and 17 species was the most represented family. Biological spectrum of the present study site shows that therophytes were the most dominating life-form of the swamp, representing high anthropogenic disturbance in the region and limited niche space for the vegetation. [Journal of American Science 2009: 5(1), 1-7] (ISSN: 1545-1003)

Key words: Dicotyledons, swamp

1. INTRODUCTION

Fresh water swamps are the unique ecosystems having very specific vegetation. These are sites of natural succession and therefore contain all the groups of plant kingdom in a single place. Water is the prime requisite of the vegetation of the swamp forests and any alteration in the availability of water affects their presence as well as distribution. Doon valley, situated at the foothills of the Himalaya between rivers the Yamuna and the Ganges, use to have a chain of swamps (Manhas et al., 2007). But due to anthropogenic activities these forests are disappearing at a very fast rate. Nakraunda is one of the most degraded swamps of Doon valley. Most of the area of the swamp has been converted to agriculture fields and residential colonies.

Taxonomic study of swamp forests of Doon valley was first carried out by Kanjilal in 1901, since then a number of studies have been conducted by various workers for floristic diversity (Dakshini, 1960a, 1960b, 1965, 1970 and 1974; Dhyani and Joshi, 2007; Sharma and Joshi, 2008), successional studies (Som Deva and Srivastava, 1978; Srivastava et al., 2000) and community dynamics (Manhas et al., 2007; Kandwal et al., 2007). In the present paper we have studied floristic and life-form diversity of Nakraunda swamp forest of Doon valley.

2. MATERIALS AND METHODS

Study Site

Nakraunda swamp is situated about 15 km east of Dehradun on Dehradun-Doiwala road at 30° 14' 15" N

latitude and 78° 05' 55" E longitude. Most of the swamp is urbanized. A very few patches of swampy vegetation are present here and there along the river Dholani, a tributary of the Song river.

Methodology

Plant specimens were collected, dried, poisoned and mounted on the herbarium sheets. Standard methods given in Jain and Rao (1977) for collection, preservation and maintenance of specimen in herbarium were followed. Herbariums of Forest Research Institute and Botanical Survey of India, Northern Circle were consulted for the identification of each species. Floras written by Babu (1980) and Kanjilal (1901) were used for the nomenclature of the species. These plant species were further classified; first on the basis of habit and then on basis of life-forms as defined by Raunkiaer (1934).

3. RESULTS

A total of 162 plant species were found in the present study site (Table 1). The contribution of dicotyledons was 71.0%, monocotyledons 23.5% and pteridophytes 5.6%. Table 2 reveals that Poaceae (15 genera/ 17 species) was the most dominating family of Nakraunda swamp. The other important families were Asteraceae (11 genera/ 12 species), Acanthaceae (10 genera/ 11 species), Cyperaceae (6 genera/ 9 species) and Scrophulariaceae (4 genera/ 7 species). *Cyperus* and *Polygonum*, both having three species, were the most represented genera. Classification on the basis of habit (Figure 1) shows that herbs were the main vegetation form with 44.4% contribution followed by shrubs (15.4%) and grasses (10.5%).

Table 1
Floristic diversity in the Nakraunda swamp and its comparison with other swamps of Doon valley

| Plant Groups | Families | Genera | Species | References |
|-------------------------|----------|--------|---------|-------------------------|
| Angiosperms | 53 | 130 | 155 | Dhyani and Joshi (2007) |
| Angiosperms | 71 | 218 | 278 | Sharma and Joshi (2008) |
| Total (1 + 2) | 61 | 141 | 162 | Present study |
| 1. Angiosperms (i + ii) | 55 | 135 | 153 | |
| (i) Dicotyledons | 45 | 103 | 115 | |
| (ii) Monocotyledons | 10 | 32 | 38 | |
| 2. Pteridophytes | 6 | 6 | 9 | |

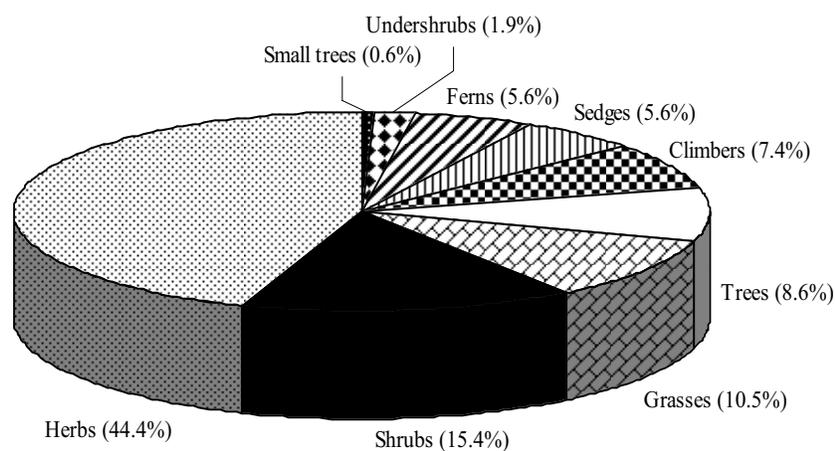

Fig 1: Pie diagram showing percentage contribution of various plant habits.

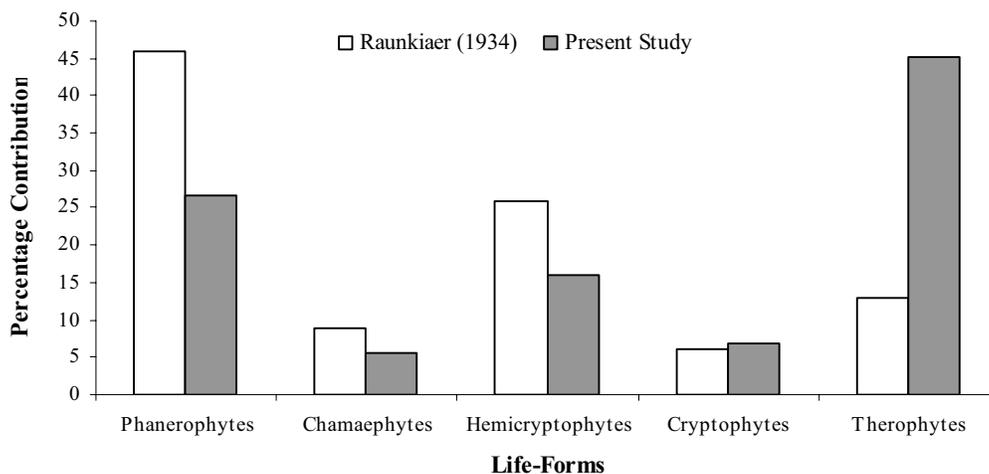

Fig 2: Biological spectrum of life-forms of present study and its comparison with the Raunkiaer's normal biological spectrum representing world flora.

Biological spectrum of the swamp was also studied (Figure 2) and compared with the Raunkiaer's normal biological spectrum (Raunkiaer, 1934) representing the world flora. Therophytes (45.1%) were

the most characteristic life-form of the present study as compared to phanerophytes in Raunkiaer's normal biological spectrum.

Table 2

List of plant species present in the Nakraunda swamp along with family, habit and life-form. The life-forms mentioned in the table are: Ph = Phanerophytes; Ch = Chamaephytes; He = Hemicyptophytes; Cr = Cryptophytes; and Th = Therophytes (for definitions see Raunkiaer, 1934).

| Plant Species | Family | Habit | Life-form |
|---|------------------|------------|-----------|
| <i>Achyranthes aspera</i> Linn. | Acanthaceae | Herb | Th |
| <i>Acorus calamus</i> Linn. | Araceae | Herb | Cr |
| <i>Adenostemma lavenia</i> (Linn.) O. Kuntze. | Asteraceae | Shrub | Ch |
| <i>Adhatoda vasica</i> Nees | Acanthaceae | Shrub | Ch |
| <i>Adiantum capillus-veneris</i> Linn. | Adiantaceae | Fern | Cr |
| <i>Adiantum incisum</i> Forssk. | Adiantaceae | Fern | Cr |
| <i>Aerva sanguinoleata</i> (Linn.) DC. | Amaranthaceae | Herb | Th |
| <i>Aerva scandens</i> Wall. | Amaranthaceae | Herb | Th |
| <i>Ageratum conyzoides</i> Linn. | Asteraceae | Herb | Th |
| <i>Alternanthera sessilis</i> R. Br. | Amaranthaceae | Herb | Th |
| <i>Amaranthus spinosus</i> Linn. | Amaranthaceae | Herb | Th |
| <i>Anagallis arvensis</i> Linn. | Primulaceae | Herb | Th |
| <i>Anisomelas indica</i> Kuntze. | Lamiaceae | Herb | Th |
| <i>Apium leptophyllum</i> (Pers.) F. Muell. Ex Benth. | Apiaceae | Herb | Th |
| <i>Arachne cordifolia</i> (Decne) Hurusawa | Euphorbiaceae | Herb | Th |
| <i>Argemone mexicana</i> Linn. | Papavaraceae | Herb | Th |
| <i>Arundo donax</i> Linn. | Poaceae | Grass | He |
| <i>Asclepias curassavica</i> Linn. | Asclepiadaceae | Shrub | Ph |
| <i>Asparagus racemosus</i> Willd. | Liliaceae | Herb | Ph |
| <i>Bacopa monniera</i> (Linn.) Wettst. | Scrophulariaceae | Herb | Th |
| <i>Bacopa procumbens</i> (Mill.) Greenm. | Scrophulariaceae | Herb | Th |
| <i>Bauhinia vahlii</i> Wight and Arn. | Caesalpiniaceae | Climber | Ph |
| <i>Bauhinia variegata</i> Linn. | Caesalpiniaceae | Tree | Ph |
| <i>Belamcanda chinensis</i> (Linn.) DC. | Iridaceae | Herb | Cr |
| <i>Bidens tripartite</i> Linn. | Asteraceae | Herb | Th |
| <i>Bischofia javanica</i> Blume | Euphorbiaceae | Tree | Ph |
| <i>Boehmeria platyphylla</i> D. Don | Urticaceae | Herb | Th |
| <i>Boerhavia diffusa</i> Linn. | Nyctaginaceae | Herb | Th |
| <i>Bombax ceiba</i> Linn. | Bombaceae | Tree | Ph |
| <i>Butea monosperma</i> (Lamk.) Taub. | Fabaceae | Tree | Ph |
| <i>Caesalpinia decapetala</i> (Roxb.) Alston | Caesalpiniaceae | Climber | Ph |
| <i>Calamus tenuis</i> Roxb. | Palmaceae | Shrub | Ph |
| <i>Capparis zeylanica</i> Linn. | Capparidaceae | Climber | Ph |
| <i>Capsella bursa-pastoris</i> (Linn.) Medic | Brassicaceae | Herb | Th |
| <i>Carissa opaca</i> stapf. | Apocynaceae | Shrub | Ph |
| <i>Cassia tora</i> Linn. | Caesalpiniaceae | Herb | Th |
| <i>Cheilanthes farinosa</i> Blanford | Sinopteridaceae | Fern | Cr |
| <i>Chenopodium album</i> Linn. | Chenopodiaceae | Herb | Th |
| <i>Chenopodium ambrosioides</i> Linn. | Chenopodiaceae | Herb | Th |
| <i>Chloris dolichostachya</i> Lagasca | Poaceae | Grass | He |
| <i>Clerodendron viscosum</i> Vent. | Verbenaceae | Undershrub | Ph |
| <i>Coccinea grandis</i> (Linn.) Voigt. | Cucurbitaceae | Climber | Ph |
| <i>Coix lachrymal-jobi</i> Linn. | Poaceae | Grass | He |

| | | | |
|--|------------------|------------|----|
| <i>Commelina benghalensis</i> Linn. | Commelinaceae | Herb | Th |
| <i>Corchorus acutangular</i> Lamk. | Tiliaceae | Herb | Th |
| <i>Coronopus didymus</i> (Linn.) J.E. Smith | Brassicaceae | Herb | Th |
| <i>Crotalaria albida</i> Heyne. | Fabaceae | Herb | Th |
| <i>Curculigo orchioides</i> Gaertn. | Hypoxidaceae | Herb | Cr |
| <i>Cyathocline purpurea</i> (D.Don) O. Kuntze | Acanthaceae | Herb | Th |
| <i>Cynodon dactylon</i> (Linn.) P. Beauv. | Poaceae | Grass | He |
| <i>Cyperus iria</i> Linn. | Cyperaceae | Sedge | He |
| <i>Cyperus niveus</i> Retz. | Cyperaceae | Sedge | He |
| <i>Cyperus rotundus</i> Linn. | Cyperaceae | Sedge | He |
| <i>Desmodium trifolium</i> DC. | Fabaceae | Herb | Th |
| <i>Dicliptera roxburghiana</i> Nees | Acanthaceae | Herb | Th |
| <i>Digitaria adscendens</i> (HBK) Henr. | Poaceae | Grass | He |
| <i>Digitaria ischaemum</i> | Poaceae | Grass | He |
| <i>Dioscorea bulbifera</i> Linn. | Dioscoreaceae | Climber | Ph |
| <i>Dryopteris cochleata</i> (D.Don) C. Chr. | Aspidaceae | Fern | Cr |
| <i>Duchesnea indica</i> Focke. | Rosaceae | Herb | Th |
| <i>Echinochloa colonum</i> (Linn.) Link. | Poaceae | Grass | He |
| <i>Eclipta prostrata</i> Linn. | Asteraceae | Herb | Th |
| <i>Emilia sonchifolia</i> DC. | Asteraceae | Herb | Th |
| <i>Eranthemum nervosum</i> (Vahl) R.Br. | Acanthaceae | Herb | Th |
| <i>Eriophorum comosum</i> Wall. | Cyperaceae | Sedge | He |
| <i>Eupatorium adenophorum</i> Spreng. | Asteraceae | Herb | Th |
| <i>Euphorbia hirta</i> Linn. | Euphorbiaceae | Herb | Th |
| <i>Ficus palmata</i> Forssk. | Moraceae | Tree | Ph |
| <i>Ficus religiosa</i> Linn. | Moraceae | Tree | Ph |
| <i>Fimbristylis dichotoma</i> (Linn.) Vahl. | Cyperaceae | Sedge | He |
| <i>Fimbristylis falcata</i> (Vhl) Kunth | Cyperaceae | Sedge | He |
| <i>Flacourtia indica</i> (Burm. f.) Merr. | Flacourtiaceae | Shrub | Ph |
| <i>Flemingia bracteata</i> Wight | Fabaceae | Shrub | Ph |
| <i>Floscopa scandens</i> Lour. | Commelinaceae | Herb | Th |
| <i>Galinsoga parviflora</i> Cav. | Asteraceae | Herb | Th |
| <i>Hemigraphis rupestris</i> Heyne ex T. Anders. | Acanthaceae | Herb | Th |
| <i>Holarrhena antidysentrica</i> Wall. | Apocynaceae | Small tree | Ph |
| <i>Holoptelia integrifolia</i> (Roxb.) Planch. | Ulmaceae | Tree | Ph |
| <i>Ichnocarpus frutescens</i> (Linn.) R. Br. | Apocynaceae | Climber | Ph |
| <i>Imperata cylindrical</i> (Linn.) Beauv. | Poaceae | Grass | He |
| <i>Ipomoea palmata</i> Forsk. | Convolvulaceae | Climber | Ph |
| <i>Ipomoea quamoclit</i> Linn. | Convolvulaceae | Climber | Th |
| <i>Isachne globosa</i> (thumb.) O. Kuntze | Poaceae | Grass | He |
| <i>Jasminum multiflorum</i> (Burm. f.) Andr. | Oleaceae | Climber | Ph |
| <i>Juncus bufonius</i> Linn. | Cyperaceae | Sedge | He |
| <i>Justicia gendarussa</i> Linn. | Acanthaceae | Shrub | Ch |
| <i>Justicia quinqueangulqris</i> Koenig ex Roxb. | Acanthaceae | Shrub | Ch |
| <i>Kyllingia triceps</i> Rottb. | Cyperaceae | Sedge | He |
| <i>Lantana camara</i> Linn. | Verbenaceae | Shrub | Ph |
| <i>Lepidagathis cuspidate</i> Nees | Acanthaceae | Shrub | Ph |
| <i>Lindernia ciliate</i> (Col.) Pennell | Scrophulariaceae | Herb | Th |
| <i>Lindernia crustata</i> (Linn.) F. Muell. | Scrophulariaceae | Herb | Th |
| <i>Lygodium flexuosum</i> (Linn.) Sw. | Schizaeaceae | Fern | Cr |
| <i>Mallotus philippensis</i> Muell. Arg. | Euphorbiaceae | Tree | Ph |
| <i>Malvaviscus penduliflorus</i> DC. | Malvaceae | Shrub | Ph |
| <i>Martynia annua</i> Linn | Martyniaceae | Undershrub | Th |

| | | | |
|--|------------------|------------|----|
| <i>Mazus pumilus</i> (Burm. f.) Steenis | Scrophulariaceae | Herb | Th |
| <i>Mentha piperita</i> Linn. | Lamiaceae | Herb | Th |
| <i>Mimosa pudica</i> Linn. | Mimosaceae | Shrub | Ch |
| <i>Monochoria vaginalis</i> Presl. | Pontederiaceae | Herb | Th |
| <i>Morus alba</i> Linn | Moraceae | Tree | Ph |
| <i>Murraya koenigii</i> (Linn.) Spreng. | Rutaceae | Shrub | Ph |
| <i>Narenga porphyrocoma</i> (Hance ex Trim.) Bor | Poaceae | Grass | He |
| <i>Nepeta hindostana</i> (Roth.) Haines | Lamiaceae | Herb | Th |
| <i>Ocimum gratissimum</i> Linn. | Lamiaceae | Herb | Th |
| <i>Oenanthe stolonifera</i> DC. | Apiaceae | Herb | Th |
| <i>Ophioglossum reticulatum</i> Linn. | Ophioglossaceae | Fern | Th |
| <i>Ophioglossum vulgatum</i> Linn. | Ophioglossaceae | Fern | Th |
| <i>Oplismenus compositus</i> (Linn.) P. Beauv. | Poaceae | Grass | He |
| <i>Panicum miliaceum</i> Linn. | Poaceae | Grass | He |
| <i>Parthenium hysterophorus</i> Linn. | Asteraceae | Shrub | Th |
| <i>Paspalum distichum</i> Linn. | Poaceae | Grass | He |
| <i>Passiflora incarnate</i> Linn. | Passifloraceae | Climber | Ph |
| <i>Phlogacanthus thyrsoformis</i> (Hardw.) Mabb. | Acanthaceae | Shrub | Ch |
| <i>Phoenix acaulis</i> Buch. | Palmaceae | Tree | Ph |
| <i>Phragmites karka</i> Trin | Poaceae | Grass | He |
| <i>Phyla nodiflora</i> Linn. | Verbenaceae | Herb | Th |
| <i>Phyllanthus niruri</i> Linn. | Euphorbiaceae | Herb | Th |
| <i>Pilea scripta</i> (Buch.- Ham. ex D.Don) Wedd. | Urticaceae | Undershrub | Ph |
| <i>Plantago major</i> Linn. | Plantaginaceae | Herb | Th |
| <i>Plumbago zeylanica</i> Linn. | Plumbaginaceae | Herb | Th |
| <i>Pogostemon plectranthoides</i> Desf. | Lamiaceae | Shrub | Ch |
| <i>Polygonum barbatum</i> Linn. | Polygonaceae | Herb | Th |
| <i>Polygonum hydropiper</i> Linn. | Polygonaceae | Herb | Th |
| <i>Polygonum plebejum</i> R. Br. | Polygonaceae | Herb | Th |
| <i>Pouzolzia pentandra</i> (Roxb.) Benn. | Polygonaceae | Herb | Th |
| <i>Pteris quadriaurita</i> Retz. | Pteridaceae | Fern | Cr |
| <i>Pteris villata</i> Linn. | Pteridaceae | Fern | Cr |
| <i>Pyrus pashia</i> Buch.- Ham. ex D. Don | Rosaceae | Tree | Ph |
| <i>Ranunculus sceleratus</i> Linn. | Ranunculaceae | Herb | Th |
| <i>Rorripa nasturtium-aquaticum</i> (Linn.) Hayek. | Brassicaceae | Herb | Th |
| <i>Rotula aquatica</i> Lour. | Boraginaceae | Herb | Th |
| <i>Rouvolfia serpentine</i> (Linn.) Benth.- ex Kurz. | Apocynaceae | Shrub | Ch |
| <i>Rubus niveus</i> Thunb. | Rosaceae | Shrub | Ph |
| <i>Rumex nepalensis</i> Spreng. | Polygonaceae | Herb | Th |
| <i>Rungia pectinata</i> (Linn.) Nees | Acanthaceae | Herb | Th |
| <i>Scirpus juncooides</i> Roxb. | Cyperaceae | Sedge | He |
| <i>Setaria glauca</i> Baeuv. | Poaceae | Grass | He |
| <i>Shorea robusta</i> Gaertn. f. | Dipterocarpaceae | Tree | Ph |
| <i>Sida cordifolia</i> Linn. | Malvaceae | Herb | Th |
| <i>Smilax zeylanica</i> Linn. | Liliaceae | Climber | Ph |
| <i>Solanum hispidum</i> Pers. | Solanaceae | Shrub | Ph |
| <i>Solanum torvum</i> Swartz. | Solanaceae | Shrub | Ph |
| <i>Sporobolus diander</i> Beauv. | Poaceae | Grass | He |
| <i>Sporobolus indicus</i> R. Br. | Poaceae | Grass | He |
| <i>Stellaria media</i> Linn. | Caryophyllaceae | Herb | Th |
| <i>Syzygium cumini</i> (Linn.) Skeel | Myrtaceae | Tree | Ph |
| <i>Tectona grandis</i> Linn. f. | Verbenaceae | Tree | Ph |
| <i>Trifolium repens</i> Linn. | Fabaceae | Herb | Th |

| | | | |
|--|------------------|---------|----|
| <i>Triumfetta rhomboidea</i> Jacq. | Tiliaceae | Herb | Th |
| <i>Vallisneria spiralis</i> L. | Alismaceae | Climber | Ph |
| <i>Vernonia anthelmintica</i> Willd. | Asteraceae | Herb | Th |
| <i>Vernonia cineria</i> (Linn.) Lees. | Asteraceae | Herb | Th |
| <i>Veronica agrestis</i> H.K.f. | Scrophulariaceae | Herb | Th |
| <i>Veronica anagallis</i> Linn. | Scrophulariaceae | Herb | Th |
| <i>Vicia sativa</i> Linn. | Fabaceae | Herb | Th |
| <i>Vitex negundo</i> Linn. | Verbenaceae | Shrub | Ph |
| <i>Woodfordia fruticosa</i> (Linn.) Kurtz. | Lythraceae | Shrub | Ph |
| <i>Xanthium strumarium</i> Linn. | Asteraceae | Shrub | Th |
| <i>Youngia japonica</i> DC. | Asteraceae | Herb | Th |
| <i>Zeuxine strateumatica</i> (Linn.) Schltr. | Orchidaceae | Herb | Cr |
| <i>Ziziphus mauritiana</i> Lam. | Rhamnaceae | Shrub | Ch |

4. DISCUSSION

The floristic diversity (162 plant species) is very less as compared to Mothronwala swamp (Sharma and Joshi, 2008), and higher than Karwapani swamp (Dhyani and Joshi, 2007). The possible reason for less floristic diversity may be closeness of swamp to human habitations and dependence of human population on these swamp forests for fuelwood, fodder, food, medicinal plants etc. Sharma and Joshi (2008) have also given similar reasons for the dwindling diversity and degradation of Mothronwala swamp of Doon valley. We found that herbs were the most dominant habit followed by shrubs among all the plant forms. Sharma and Joshi (2008) have also reported similar results from Mothronwala swamp of Doon valley. Dominance of herbs and shrubs again signify high rate of anthropogenic disturbances.

High percentage of therophytes in the present study is an indicator of the amount of influence such as grazing (Tiwari, 2005) and anthropogenic activities like catching of fishes and other eatable fauna, collection of vegetables etc. (Manhas et al., 2007), which maintain the vegetation open for further invasion of therophytes. The dominance of therophytes also point towards the harsh environmental conditions of the swamp, which provide very limited niche space to vegetation of these marshy areas.

ACKNOWLEDGEMENTS

The authors are very thankful to the Forest Research Institute and Botanical Survey of India, Northern Circle, Dehradun for the herbarium facilities.

Correspondence to:

Dr. R. K. Manhas
Department of Botany,
Sri Pratap College,
M.A. Road, Srinagar (J and K)- 190 001, India.

REFERENCES

1. Manhas, R.K., Kandwal, Manish K., Dhyani, Sandeep, Singh, Lokender and Joshi, S.P. (2007) Effect of Soil Moisture on Demographic Dispersion, Species Association and Diversity of Primary Producers in a Sub-Tropical Swamp Forest. *Indian Forester*, 133 (4): 547-560.
2. Kanjilal, U.N. (1901) Swamp forest in D. dun, N.W. Province. *Indian Forester*, 27: 228-30.
3. Dakshini, K.M.M. (1960a) The vegetation of Mothronwala Swamp forest, A preliminary Survey. *Bulletin of Botanical Survey of India*, 9: 57-59.
4. Dakshini, K.M.M (1960b) The vegetation of Mothronwala swamp forest (Plant communities of swamp zone). *Indian Forester*, 86: 728-733.
5. Dakshini, K.M.M (1965) A study of the vegetation of Mothronwala Swamp forest Dehradun, India. *Journal of Indian Botanical Society*, 44: 441-448.
6. Dakshini, K.M.M. (1970) The flora of Mothronwala Swamp. *Journal of Bombay Natural History Society*, 67:176-186.
7. Dakshini, K.M.M. (1974) The flora of Mothronwala Swamp. *Journal of Bombay Natural History Society*, 71(2): 235-243.
8. Dhyani, S. and Joshi, S.P. (2007) Angiospermic diversity of Karwapani fresh water swamp forest in Doon valley, India. *Indian Forester*, 133 (8): 1101-1108.
9. Sharma, Neelam and Joshi, S. P. (2008) Comparative study of a Fresh water Swamp of Doon valley. *The Journal of American Science*, 4(1): 7-10.
10. Som Deva and Srivastava, M.M. (1978) An ecological study of the vegetation of Golatappar Swamp, Dehradun. *Indian Journal of Forestry*, 1(1): 44-52.
11. Srivastava, M. M., Joshi, S.P., Ghildiyal, J.C., Manhas, R. K. and Kumar, Vinod. (2000) Demography and successional trends in Fresh

- water swamps of Dehra Dun Valley (UP) India. In: Landmarks of Botany in India (eds.: P. Soni and N.R. Dasturiya). Surya Publications, D. Dun: pp 113–123.
12. Kandwal, Manish K., Manhas, R.K., Joshi, S.P. and Singh, Lokender. (2007). Phytosociological studies of herbaceous layer in a fresh water swamp at Golatappar, Dehra Dun. *Annals of Forestry*, 15 (1): 47-61.
 13. Jain and Rao (1977) A Handbook of field and Herbarium methods. Today and Tomorrow's printers and Publishers, New Delhi.
 14. Babu, C.R. (1977) Herbaceous Flora of Dehra Dun. Publication and Information Directorate, CSIR, New Delhi.
 15. Raunkiaer, C. (1934) The life forms of plants and statistical plant geography. Clarendon Press, Oxford.

HISTOLOGICAL INTERACTIONS OF PAECILOMYCES LILACINUS AND MELOIDOGYNE INCOGNITA ON BITTER GOURD

¹Mohd Yaqub Bhat, ²Hissa Muddin, ³Nazir Ahmad Bhat

¹Deptt. of Botany, University of Kashmir, Srinagar - 190006.

²Plant Pathology Section, Aligarh Muslim University, Aligarh -202002, India.

³A.P.S.U.Rewa, M.P. India

E-mail: myaqub35@gmail.com

ABSTRACT: *Momordica charantia* roots were histologically examined for the interaction of *Meloidogyne incognita* and the fungus *Paecilomyces lilacinus* which was applied at different time intervals. *Meloidogyne incognita* induced large sized galls on the plants which were treated with *P.lilacinus*. Fully mature females were found associated with giant cells. All the mature females on the roots of untreated, *Meloidogyne incognita* infected plants laid egg masses. The xylem and the phloem exhibited abnormalities in structure near the giant cells. Abnormal vessel elements were occupying larger area near giant cells. The fungus *P.lilacinus*. Soon after the application, entered the roots and spread through the lumen of the vessel elements. The plants that were treated with fungus either one week before nematode inoculation or simultaneously, produced significantly ($P= 0.01$) small sized galls in comparison to untreated plants. The size of galls remained unchanged after completion of one life cycle by the nematode. In fungus treated plants the giant cells were small sized and the abnormality of vascular plants was less. *Paecilomyces lilacinus* entered the giant cells and also into the body of mature females. It destroyed the eggs and egg masses in and out side females. The fungus by destroying eggs checked the possibility of secondary infection that ultimately arrested increase of gall size. [Journal of American Science 2009: 5(1), 8-12] (ISSN: 1545-1003)

Key words: Abnormality, gall, giant cell, histology, vascular tissue.

1. INTRODUCTION

The fungus *Paecilomyces lilacinus* (Thom) Samson has been reported as a potential biological control agent for root-knot nematode and other plant parasitic nematodes (Jatala, et al., 1979, 1982, 1986; Adiko, 1984; Cardona and Leguizamón, 1997 and Khan and Williams, 1998). *P. lilacinus* is common soil hypomycete closely related to *Penicillium* (Samson, 1975). The sedentary stages of the root-knot and cyst nematode are most vulnerable to *P. lilacinus*. The fungus is capable of colonising nematode reproductive structures thus causing destruction of females, cysts and eggs. (Franco, et al., 1981, Jatala, 1982, 1986; Gintis, et al., 1983 and Cardona and Leguizamón, 1997).

Paecilomyces lilacinus increased the yield of tomato and okra and lowered the population of *M. incognita* juveniles, at the mid and at the beginning of the next season in treated pots than in untreated pots (Neo and Sasser 1984). *M. incognita* juveniles when exposed to fungus resulted in reduced gall formation and egg mass production.

The association of *P.lilacinus* with the eggs of *M.incognita* is well documented but the exact mode of its parasitism is unknown. Root galling and giant cell formation were absent in tomato roots inoculated with fungus infected eggs of *M.incognita*. *P. lilacinus* colonised surface of epidermal cells as well as the internal cells of cortex of tomato roots

(Cabanillas et al., 1988). The effects of fungus on *M.incognita* parasitizing the roots of *Momordica charantia* has not yet been reported. The objectives of this study were : (i) to examine the effect of *P.lilacinus* on *M.incognita* infected plant tissues. (ii) to know the effect of *P.lilacinus* on nematode development, (iii) to determine the effect of *P.lilacinus* on eggs and egg masses, (iv) to examine the effect of *P.lilacinus* on the giant cells and (v) to evaluate the efficacy of *P.lilacinus* in controlling the disease development, on applying the fungus at varying time intervals, before or after nematode inoculation.

2. MATERIALS AND METHODS

Nematode cultures of *Meloidogyne incognita* was maintained from single egg mass on egg plant (*Solanum melongena* L.) grown in green house in 15 cm diameter earthen pots containing a mixture of steam sterilized soil and sand (3:1). *M.incognita* originally was isolated from vegetable crop fields of Aligarh. The root-knot nematode was identified on the basis of characteristic perineal pattern and North Carolina differential host test. Freshly hatched second stage juvenile inoculum was prepared by hatching egg masses picked from egg plant roots, maintained as pure culture in green house. *Paecilomyces lilacinus*, used in the experiment, was obtained from international potato centre, Lima,

Peru. The fungus was cultured on PDA for 15 days at then inoculated to Richards Medium (Riker and Riker, 1936) for en-masse propagation .The mycelia (100 gm) were blended in distilled water (100 ml) in warring blender to make mycelial suspension for soil application (10 ml of suspension containing 1gm mycelia).The fungus was applied into the rhizosphere zone by making three or four holes around the plant.

Plant Materials : Seeds of *Momordica charantia* L. variety NSC were surface sterilised with 1% sodium hypochlorite (NaOCl) for five minutes and rinsed three times with sterile distilled water. 100-150 axenised seeds were placed on a moist sterilised filter paper kept in sterilised petri dishes. Seeds were allowed to germinate. The germinated seeds were transferred to 15 cm diameter clay pots filled with autoclaved soil, sand and farmyard manure in the ratio of 7:3:1. Two week old seedlings were inoculated with a suspension of 1000 J2 pipetted into root zone via the holes in the rhizosphere zone around plant in each pot. To achieve the aim and objective the experiment was designed as per the following treatment schedule

- 1) T₁- un-inoculated control
- 2) T₂- inoculated with 1,000 J2 only
- 3) T₃- inoculated with 1,000 J2 and treated with fungus one week before inoculation

27±2⁰C,

- 4) T₄- inoculated with 1,000 J2 and treated with fungus simultaneously
- 5) T₅- inoculated with 1,000 J2 and treated with fungus two week after inoculation

Each treatment was replicated five times, arranged in randomised block design. Each set of plants was uprooted carefully after 45days . The roots were cut into small pieces and processed for histopathological studies. Root pieces were fixed in formalin- aceto - alcohol (F.A.A) and then dehydrated through tertiary-butyl-alcohol (T.B.A.) schedule as given by Johansen (1940). Infiltration and embedding of root pieces in paraffin wax was followed and sections of 12µm thickness were taken with the help of rotary microtome in the form of ribbon. The ribbons were cut into small pieces and mounted on clean slides with the help of Haupt's adhesive and 3% formalin and stained with safranin and fast green (Sass1951). The slides were taken out from xylene. The mounting medium was applied on the surface of slide before evaporation of xylene and cover slip was lowered gradually. Finished slides were left at room temperature at least for 24 hours and then kept in an incubator at 40⁰C. The slides were examined under light microscope and necessary photographs were taken.



Fig 1: Showing heavy infestation of *Meloidogyne incognita* (N). The mature females have egg masses (EM). Abnormal xylem (AX) and abnormal phloem (AP) are in abundance.(25X)

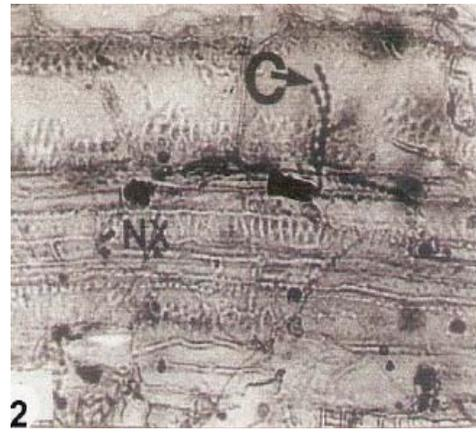

Fig 2: Showing normal xylem (NX) strands with conidiophores and conidial chain C in the lumen of vessel elements.

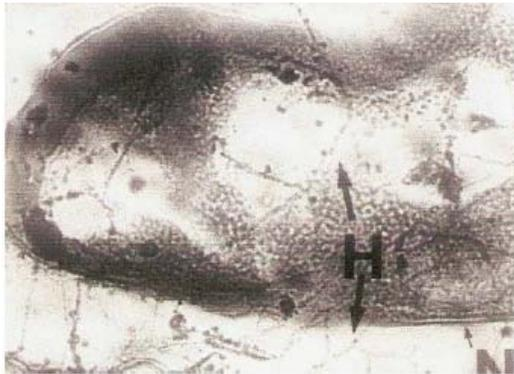

Fig 3: Showing abundant growth of *Paecilomyces lilacinus* hyphae (H) in and around the females of *M. incognita* (N).(32 X).



Fig 4: Showing hyphae (H) and conidial chains (C) at the root surface. (12.5 X)

3. RESULTS

Histologically the primary root of *Momordica charantia* consists of uniseriate epidermis, multilayered parenchymatous cortex and stele. The stele in primary root may be diarch, triarch but generally tetrarch, displaying a typical dicotyledonous pattern. Xylem and phloem are radially arranged alternating with one another. There is small pith consisting of parenchyma cells at the centre of four xylem arches. *Meloidogyne incognita* inoculated *M.charantia* plants receiving no disease controlling treatment produced large sized galls. The mature females feeding on giant cells, abnormal xylem and abnormal phloem was observed (Fig 1).All the mature females were found associated with egg masses. Histological examination of the galled roots which were given *Paecilomyces lilacinus* treatment, one week before the nematode inoculation, revealed that the fungus entered the root tissue and grew successfully. The hyphae and conidiophores, bearing chains of conidia were seen in normal vessel elements of the xylem (Fig 2).The giant cells, though smaller, resembled with those of T2 plants .In the vicinity of the giant cells abnormal

xylem and phloem were present in *Paecilomyces lilacinus* treated plants. The abnormality in vascular elements was less. The fungal hyphae destroyed eggs and egg masses and also entered into the body of the females. Around the nematode body fungal growth was abundant (Fig 3).The root surface also exhibited profused growth of fungus (Fig 4). The simultaneous application of root knot nematode and *Paecilomyces lilacinus* not only destroyed eggs and egg masses, but also entered into the internal tissues of root, either intercellularly or intracellularly as is evident from the transverse sections of vessel elements (Fig 5).The egg masses were destroyed by the fungus and the growth of fungus was profound inside egg masses. There was no change in the size of giant cells and amount of vascular elements as compared to untreated plants. In plants treated with *Paecilomyces lilacinus*, one week after nematode inoculation, the fungal hyphae was observed inside the giant cells (Fig 6).The fungal growth was profuse around the body of developing nematodes. In the normal tissue the fungus spreads both inter and intracellularly as is evident from figure (Fig.7)



Fig 5: Showing vessel elements (VE) in transverse sections enclosing conidial chains (C).(40 X)



Fig 6: Showing hyphae (H) in giant cell (GC) and nematode (N) adjacent to giant cell.(25 X)



Fig 7: Showing normal xylem (NX) strands with hyphae(H) of Paecilomyces lilacinus traversing through the lumen of vessel elements. (32 X)

DISCUSSION

The fungus *Paecilomyces lilacinus* shows diverse modes of habits. Basically it is a saprophyte (Domsch et al., 1980) and can easily be grown on artificial culture media. It behaves as an epiphyte and grows on the surface of plant roots (Cabanillas et al., 1988). It also grows inside the root tissue and behaves as an endophyte and does not cause any damage to the plant. Still at other times it parasitizes eggs and egg masses of *Meloidogyne* species and destroy them. Because of the lastly stated behaviour, *P.lilacinus* has been used by several workers, as biocontrol agent against root-knot nematode and other nematodes (Jatala, et al., 1979).

Paecilomyces lilacinus was encountered frequently in and around normal and abnormal xylem. In our opinion, vessels and vessel elements provide sufficient space for its development and also provide an uninterrupted passage to grow inside the plant tissues. We consider that *P.lilacinus* develops inside the root tissues inter and intracellularly. Whether the fungus is beneficial or not to plant but, it is not harmful. In all the sections studied, the fungus was not found damaging the plant tissues even when it was in abundance. Further it did not affect the giant cells in which its occurrence was noted. In all the treatments it was regularly observed that *P.lilacinus* damage the eggs and egg masses. Various workers have reported egg destroying activity of this fungus (Jatala, et al., 1979, Jatala, 1985, 1986.) It has also been reported that the fungus can destroy neither the juveniles nor the adult females (Jatala, 1986). The eggs however seem to be the most preferred target for obtaining the nourishment by the fungus. Contrary to this (Cardona and Leguizamon, 1997) reported 94% infection in *Meloidogyne* spp. by *P. lilacinus* strain-9207. KHAN and WILLIAMS (1998) found *P.lilacinus* entering into the body of the females through natural opening. They did not mention whether the fungus damaged the females or not, although it damaged the eggs inside the egg masses. Small sized giant cells and small amount of

abnormal xylem and phloem indicated that the nematode activity and development was influenced by the presence of *P.lilacinus*. Large giant cells and more quantity of abnormal tissues showed that the nematodes which entered earlier were not affected by the fungus. On the basis of these observations we concluded that the fungus can not check primary infection of nematode when the plants are attacked by the juveniles. However, it can check secondary infection because it destroys eggs as and when these are deposited. As far as time of application of *P.lilacinus* is concerned, from our studies it can be suggested that incorporation of fungus *P.lilacinus* one week before and at the time of nematode inoculation is more effective in controlling the root-knot disease, as compared to later intervals of fungus applications.

ACKNOWLEDGEMENT

The authors are thankful to Chairman, Department of Botany, Aligarh Muslim University, Aligarh for providing necessary facilities to complete this work.

REFERENCE

1. Adiko, A., 1984. Biological control of *Meloidogyne incognita* with *Paecilomyces lilacinus*. M.S. Thesis, Department of plant pathology, North Carolina State University, Raleigh,
2. Cabanillas E., Barker, K.R. and Daykin, M.I. 1988. Histology of the interactions of *Paecilomyces lilacinus* with *Meloidogyne incognita* on tomato. *J. Nematol.* 20: 362-265.
3. Cardona, B.N.L. and Leguizamon, C. J. E. 1997. Isolation and pathogenicity of fungi and bacteria to the root-knot nematode of coffee *Meloidogyne* spp. *Goldi. Fitopatologia Colombiana* . 21: 39-52,

4. Domsch, K.H., Gams, W. and Anderson, T. H. 1980 .Compendium of soil fungi. Vol. 1: Academic press, New york, pp.859.
5. Franco, J., P. Jatala, and . Bocangel, B. 1981. Efficacy of *Paecilomyces lilacinus* as biocontrol agent on *Globodera pallida*.. J. Nematol. 13: 438-439.
6. Gintis, B.O., Morgan-jones, G. and Rodriguez-Kabana. R. 1983. Fungi associated with several developmental stages of *Heterodera glycines* from an Alabama soybean field soil. *Nematropica* .13: 181-200.
7. Jatala, P.,1982. Biological control with fungus *Paecilomyces lilacinus*. Progress to date and possibilities for collaborative research between CIP and IMP. Collaborators pp.214-218. In proceedings to third research conference on root knot nematodes *Meloidogyne* spp.22-26 March,1982,Region 2,Raleigh;North Carolina State University , Graphics.
8. Jatala, P. 1985. Biological control of nematodes. p 301-303. - In advanced Treatise on *Meloidogyne* Vol.1: Biology and Control Eds. J.N. Sasser and C.C Carter. A cooperative publication of the department of Plant Pathology and U.S.AID, N.C.S.U. Graphics pp.422.
9. Jatala, P.1986. Biological control of plant parasitic nematodes. - Ann. Rev. Phytopath. 24: 453-489
10. Jatala, P., Kaltenback, R. and Bocangel, M., 1979. Biological control of *Meloidogyne acrita* and *Globodera pallida* on potatoes. J. Nematol. 11: 303.
11. Johansen, D.A.1940. In Plant Microtechnique Mc Graw Hill, New Book Co. New York, 523 pp.
12. Khan, A. and K. L. Williams, 1998. Recent studies on *Paecilomyces lilacinus* as bionematicide. *Nematologica* 44: 519-520.
13. Neo, J.P and Sasser, J. N. 1985. Evaluation of *Paecilomyces lilacinus* as an agent for reducing yield losses due to *Meloidogyne incognita*. *Biocontrol*. 1: 57-67.
14. Riker, A.J and Riker, R.S., 1936. Introduction to research on plant disease. St. Louis and New York, John S, Swift Co., 117p.
15. Samson, R.A. 1975. *Paecilomyces* and some allied hypomycetes. *Studies in Mycology* 6: 1-119.
16. Sass. J.E.1951. In Botanical Microtechnique, Iowa College Press, Ames, Iowa, 228 pp.

Experimental Study on The Dynamic Behaviors of the Material for Clay core wall sand dams

Xu Shangjie^{1,2}, Dang Fanning¹, Tian Wei¹, Cheng Mo²

1. Xi'an University of Technology, Xi'an, Shanxi, 710048, China;

2. Shandong Provincial Institute of Water Resources, Ji'nan, Shandong, 250013, China

xushangjie@sina.com

Abstract: The Clay core wall sand dams are mostly constructed on the tremendously thick covering layers with the base built with gravelly coarse sand and the upstream and downstream built with sanded shell into which gravelly coarse sand by manpower. The structures of these dams are generally loose and are presumably thereby considered not to meet the requirements against earthquake. In order to perform further safety analysis and liquefaction judgment with these dams in relation to their anti-seismic capacity, a typical dam with clay core and sanded shell was chosen and experiments were carried out to observe the dynamic behaviors of the dam, including the dynamic strength, the dynamic deformation and the dynamic pore pressure of the dam base and its upstream sanded shell. The results showed that the vibration stress ratio of gravelly coarse sand decreased with the increment in vibration frequency and increased with the increment in consolidation ratio, that the elastic modulus of gravelly coarse sand decreased with the increment in strain, and that the damping ratio of gravelly coarse sand increased with the increment in strain. In conclusion, the denser the dam material is, the better the anti-seismic behavior is, the sand used in the dam is non-linear in nature, The model of vibration pore water pressure growth is characterized by simplicity in expression, convenience in application, and being able to used in widespread way, etc. It reveals what inherent in the relationship of the increment of residual pore pressure with multiple factors, and hence can be used in the dynamic analysis of effective stress. [Journal of American Science 2009:5(1) 13-18](ISSN: 1545-1003).

Key words: gravelly coarse sand, earthquake liquefaction, dynamic behaviors, upstream sanded shell

1 Introduction

More than 90% of reservoirs were constructed during the period of the so-called "Great leap forward" around the year of 1958 as some kind of special products with most of the dams being of clay-core-sand-shell type. And the filling of these dams were accomplished using the so-called "tactics of human sea" with their internal structures comparatively loosely built with no consideration into their capacity against seism at all. Consequently, these dams have been presumed not to be able to reach anti-seismic requirements from the beginning. Even worse, these dams have undergone operation of 50 years with severe problems associated with aging. Therefore, it has been extremely critical to evaluate the real property of anti-seism of these dams so as to perform reasonable measures for improving their anti-seismic capacity, and thus reducing probability of

their leading to catastrophic outcomes brought by possibly occurring seism in the future while leaving them there for multiple usages. In this study, the materials from the dam for Houlonghe reservoir were chosen to observe experimentally their dynamic properties with respect to the anti-seismic capacity of the present dam made from them. The dam for Houlonghe reservoir is located on the middle stream of the east branch of Gu river at Yatou town, Rongcheng city, Shandong province, China, which is a typical clay-core-sand-sand-shell dam. This dam controls water flow of about 61km². And the reservoir with a total capacity of about 5.3 millionm³, is a important medium sized one of its kind and comprehensively applied for flood prevention and water supply. The dam was constructed in 1959 and has affiliated with aging diseases seriously after undergoing operation of 50

years. In 2004, it was listed as dangerous one after safety assessment by the national security department for reservoir and dam, and thus needs danger control and reinforcement.

The dam is a clay-core-shell-wall dam with its upstream being sanded shell and its base made from gravelly coarse sand. The reservoir has been set to be in defense against earthquake of seven degrees by Richter scale. But the judgment has been made through reconnaissance that there has been existing the probability of seismic liquefaction with the sanded shell in the upstream of the dam and the sanded layer in the base of it in the circumstance of earthquake. Therefore, we carried out the research to study the dynamic

characteristics of gravelly coarse sand in order to provide theoretical basis for related institutions involving in the analysis of the dynamic safety of the dam and supply data for the evaluation of seismic liquefaction.

2 Samples for the experimentation

The experimental soil material was the loose soil obtained from the typical sections of sanded shell in the upstream and the sand layer at the base of the dam for Houlonghe reservoir. The characteristics of the two soils were shown in table 1. The dry density of them: the soil of the upstream sanded shell: $\gamma_d=1.62\text{g/cm}^3$, the soil of the sand layer at dam base: $\gamma_d=1.58\text{g/cm}^3$.

Table1.

the characteristics of soils obtained from sanded shell in the upstream and sand layer at the base

| sampling positions | sampling depth (m) | particle size (mm)/% | | | | | nonuniform coefficient | curvature coefficient | Name in door |
|----------------------------|--------------------|----------------------|-------|----------|------------|--------|------------------------|-----------------------|----------------------|
| | | >2 | 2~0.5 | 0.5~0.25 | 0.25~0.075 | <0.075 | | | |
| upstream sanded shell | 3.0 | 13.7 | 29.1 | 32.4 | 19.0 | 5.8 | 5.91 | 1.41 | gravelly coarse sand |
| the sand layer at dam base | 1.5 | 22.6 | 33.2 | 28.2 | 12.8 | 3.2 | 9.73 | 1.08 | gravelly coarse sand |

3 METHODS OF EXPERIMENTATION

The DSZ-100 electromagnetic vibration triaxial apparatus was employed for the observation of the seismic behavior of the material of the dam. The sample was 3.91cm in diameter, 8cm in high, and greater than 90% in saturation. Three consolidation ratios were used in this experiment: $K_c=1.0,1.5,2.0$. The consolidation stresses were 0.05MPa,0.10MPa,0.15MPa, respectively. Sine wave with 1Hz in frequency was used with dynamic wave is.

Method for liquefaction experiment: The tested sample was prepared in such way that a given amount of dried sand by baking was mixed with water,and then boiled to be dried after thorough stirring. The process of consolidation of the sample was accomplished by applying axial stress σ_1 and lateral stress σ_3 to the sample under desired conditions and then the liquefaction test was performed by applying given axial circulation stress in the circumstance of no draining.

Method for measuring dynamic elastic modulus

and damp ratio: Dynamic elastic modulus (E_d) is the ratio of dynamic-stress σ_d and dynamic-strain ϵ_d , which reflects the relationship between dynamic-stress and dynamic-strain during the phase of modification in shape under the action of periodically loading. Damp ratio λ is the ratio of damp coefficient c and critical damp coefficient c_{cr} , measured by cyclic triaxial test, indicating the energy-dissipation per vibrating cycle, and is therefore also called the equivalent gummy damp ratio of soil. The method used for examining dynamic-elastic modulus and damp ratio in this study was as follows: the samples were consolidated with different stresses, and then the samples were respectively implemented with dynamic stresses from low grade to high grade progressively in step with 10 times per graded cycle in under the circumstance of non-draining. The resultant hydraulic pressure in the accessory small openings in the samples was dissipated after the termination of every graded loading before the implementation of the next graded loading in order to keep the valid stress constant during the process of the test.

The criteria for demolition examination at equal consolidation was set at 5% of the peak of the axial strain (double peaked value). The criteria for demolition examination at non-equal consolidation was also set at 5% of the axial halved peak value plus residual deformation.

4 DYNAMIC CHARACTERISTICS OF THE MATERIALS OF THE DAM

4.1 The characteristics of Dynamic Intensity

Dynamic intensity refers to the dynamic shearing stress leading to sample failure with a given number of circulating vibration force, N_f . The relationship curve, $\sigma_d/(2\sigma_3) \sim N_f$ was displayed on uni-logarithm graph sheet base on the results of the test. The curve was established with the results of the test when the number

of circulations at 10, in viewing of that the earthquake defence intensity had been set at seven degrees by Richter scale for the dam of Houlonghe reservoir. The ratios of liquefaction-stress when N_f at 10 were shown in table 2, and the relationship curve of the dynamic shearing stress ratio $\sigma_d/(2\sigma_3)$ of upstream sanded shell and the number of vibration destruction, N_f was shown in figure 1.

Table2.

liquefaction- stress ratio of the materials of the dam

| sampling positions | Liquefaction- stress ratio $\sigma_d/2\sigma_3$ | | |
|----------------------------|---|------|-------|
| | 1.0 | 1.5 | 2.0 |
| upstream sanded shell | 0.30 | 0.40 | 0.515 |
| the sand layer at dam base | 0.32 | 0.43 | 0.535 |

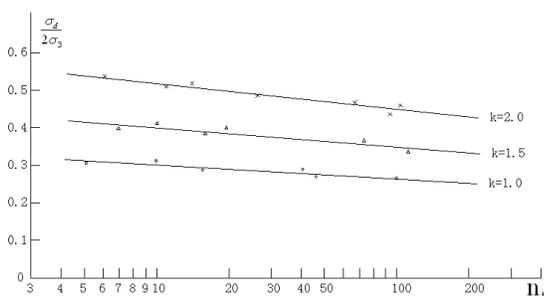

Fig 1. The relationship curve of $\sigma_d/(2\sigma_3)$

The values of dynamic stresses at different consolidation stresses were obtained from liquefaction-stress ratios when the times of circulating force at 10, and thus then the Mohr circle could be drawn for the determination of the dynamic strength parameters. The

dynamic strength parameters, Φ_d and C_d at three different consolidation stresses were shown in table 3. The Mohr circles of upstream sanded shell of the dam at different stresses were shown in figure 2.

Table3.

dynamic strength parameters at three different consolidation stresses of the materials of the dam

| sampling positions | 1.0 | | 2.0 | | 3.0 | |
|----------------------------|----------------------|----------------|----------------------|----------------|----------------------|----------------|
| | Φ_d (degree) | C_d (MPa) | Φ_d (degree) | C_d (MPa) | Φ_d (degree) | C_d (MPa) |
| upstream sanded shell | 14.81 | 0 | 25.69 | 0 | 30.55 | 0 |
| the sand layer at dam base | 14.2 | 0 | 24.6 | 0 | 30.92 | 0 |

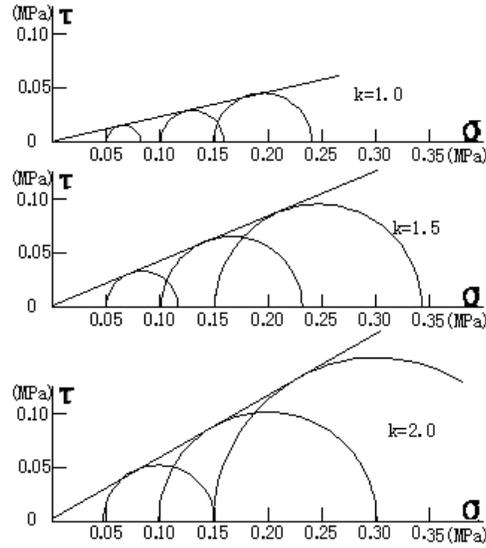

Fig 2. The Mohr circles of upstream sanded shell at different stresses(n=10).

In order to perform the liquefaction analysis, the liquefaction shearing stress, τ_{fd} , under different static stresses, σ_{fs} , had to be determined. The curve representing relationship of initial shearing stress ratio, $\beta = \tau_{fs} / \sigma_f$, with $\alpha = \tau_{fd} / \sigma_{fs}$ were obtained from the results of the test as shown in figure 3.

The shearing stress during liquefaction cycle, τ_{fd} , resulted from the combination of a certain initial effective directed stress σ_{fs} and the initial shearing stress τ_{fs} (e.g. anti-liquefaction shear stress) could be obtained from the curve.

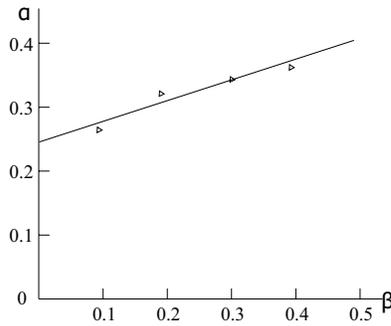

Fig 3. The relationship of α and β in upstream sanded shell

4.2 The characteristics of dynamic deformation

The relationship between the maximal dynamic elastic modulus E_{dmax} and the averaged effective consolidation pressure σ'_0 was determined, and the relationship curve of the elastic modulus E_d and damp ratio λ_d against dynamic strain ϵ_d was established for the determination of the characteristics of dynamic deformation.

According to the results of the test, the relationship of maximal dynamic elastic modulus E_{dmax} and the averaged effective consolidation stress σ'_0

was determined by the following equation.

$$E_{dmax} = kP_a \left(\frac{\sigma'_0}{P_a} \right)^n \quad (1)$$

In the equation, σ'_0 is the averaged main effective stress when samples being consolidated, which is determined by the equation: $\sigma'_0 =$

$(\sigma'_1 + 2\sigma'_3) / 3$; k and n are test constants relative to properties of soils used in tests. P_a is the atmospheric pressure.

$E_{dmax} \sim \sigma_0^N$ relationship curve was drawn on the double logarithm coordination sheet, wherein K was the intercept of the curve on the vertical axial of the

coordination, and N was the slope ratio. The values of k and n for the materials of the dam when consolidation ratio at 1 were shown in table 4.

Table4 k and n with the material of the dam

| the material of the dam | k | n |
|----------------------------|------|-------|
| upstream sanded shell | 40 | 0.681 |
| the sand layer at dam base | 38.5 | 0.635 |

The dynamic elastic modulus E_d decreased with the increasing of axial strain while it increased with the increasing of the consolidation stress ratio. Nevertheless, the ratio of modulus E_d and maximum of dynamic elastic modulus E_{dmax} , E_d/E_{dmax} did not change significantly with the alteration of consolidation pressure. The relationship of E_d/E_{dmax} and ϵ_d were depicted on the halved logarithm coordination sheet based on the results of the test. The following equation was obtained after approximation of the curve for $E_d/E_{dmax} \sim \epsilon_d$.

$$E_d/E_{dmax} = 1/(1 + \epsilon_d/w) \quad (2)$$

In the equation, w is the approximation parameter.

The curve for the relationship between damp ratio λ_d and dynamic strain ϵ_d was depicted on the halved logarithm coordination sheet. the half logarithm squared paper. The following equation was obtained after approximation of the curve for the $\lambda_d \sim \epsilon_d$ relationship:

$$\lambda_d = a\epsilon_d/(b + \epsilon_d) \quad (3)$$

In the equation, a and b are the approximation parameter.

The relationship curve of E_d/E_{dmax} , λ_d and ϵ_d with the shell of the upstream of the dam was showed in figure 4. The approximation parameter for elastic modulus w with dam material and the approximation parameters for damp ratio, a and b were shown in table 5.

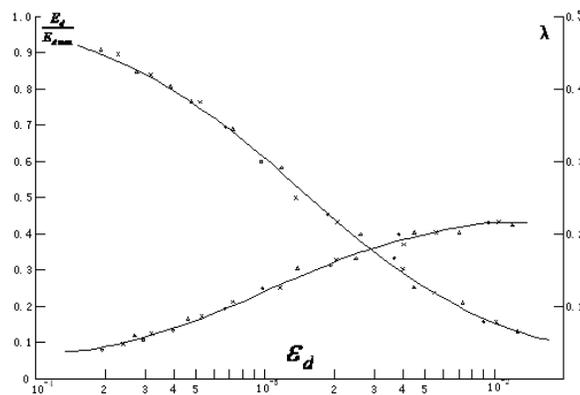

Fig 4. The respectively corresponding relationship of E_d/E_{dmax} , λ_d and ϵ_d in upstream sanded shell

Table 5.

Approximation parameter of elastic modulus damp ratio

| the material of the dam | w | a | b |
|----------------------------|----------|--------|-------|
| upstream sanded shell | 0.001596 | 0.4767 | 0.001 |
| the sand layer at dam base | 0.001303 | 0.2223 | 0.006 |

4.3 THE CHARACTERISTICS OF DYNAMIC PORE PRESSURE

During the vibrating triaxial test, the changes in small opening hydraulic pressure were recorded

simultaneously with computer and thus the curve for the relationship of changes in small opening hydraulic pressure with times of vibration was obtained. Data of the test was arranged with the vibration pore water pressure growth model proposed by the Institute of Water Resources, the Yellow River Committee, China, which is denoted in the following exponential function.

$$U = 1 - (1 - U_0)10^{-K\xi/(1-\xi)} \quad (4)$$

In the equation, ξ is the ratio of the destruction-to-times in logarithm, which could be obtained by the equation, $\xi = \log N / \log N_f$; U_0 is the relative pore pressure ratio of the first cycle.

The test constants k was determined by the following equation.

$$K = \alpha N_f^{-\beta} \quad (5)$$

U_0 was determined by the following equation.

$$U_0 = \gamma N_f^{-\theta} \quad (6)$$

N_f was determined by the following equation.

$$\alpha_d = A N_f^{-B} \quad (7)$$

Wherein α_d was the ratio of dynamil stress, which was determined by the equation, $\alpha_d = \sigma_d / (2\sigma_3)$. Thus, the pore pressure of any time vibration was determined by the following 7 constants, namely, A 、 B 、 γ 、 θ 、 α 、 β and u_f , where u_f was the averaged value of pore pressure ratio with predetermined destruction standard in the same consolidation ratio .

Different consolidation ratio and consolidation pressure has taken into consideration in this model, which is thus characterized by simplicity in expression, convenience in application, and being able to used in widespread way, etc. It revealed what inherent in the relationship of the increment of residual pore pressure with multiple factors, and hence could be used in the dynamic analysis of effective stress.

5 Conclusion

(1) The results showed in the present test with dynamic strength that the vibration-stress ratio of the material of the dam increased with the reduction of times of vibration, and the numerical points of stress ratio at different confining pressure fell relatively well into a narrowly-defined band under the same consolidation ratio and thus could be expressed as a

straight line, indicating that the results were comparatively is reasonable. The results also showed that the stress ratio of each kind of dam material increased with the increment of consolidation ratio and the dynamic strength index increased significantly with the increment of consolidation ratio, indicating that the denser the dam material is, the better the anti- seismic behavior is.

(2) The results in the dynamic modulus and damp measurements showed that the dynamic elastic modulus of the dam material decreased with the increment of the strain and damp ratio increased with the increment of the strain, indicating that the sand used in the dam is non-linear in nature. The strain ranged from 10^{-4} to 10^{-2} in this test, in which modulus ratio and damp ratio were the actual values. The values of the modulus ratio and damp ratio in other ranges could be obtained through simulation curve.

(3) The model of vibration pore water pressure growth is characterized by simplicity in expression, convenience in application, and being able to used in widespread way, etc. It reveals what inherent in the relationship of the increment of residual pore pressure with multiple factors, and hence can be used in the dynamic analysis of effective stress.

REFERENCES:

1. YUAN Ju-yun, XU Chao, ZHAO Chun-feng. Soil lab test and in-situ testing[M]. Shanghai: Tongji University Press, 2004.
2. Institute of Hydraulic Research, YRCC, Study on the anti-seismic properties of Sand and Gravel in Xiaolangdi earth rockfill dam, (national technology tacking report of 8th five-year plan), 1994.
3. Shandong Provincial Institute of Water Resources, Engineering Geological Investigation of Houlonghe reservoir in Rongcheng city.
4. XU Bin, KONG Xian-jing, ZOU De-gao, Study of dynamic pore water pressure and axial strain in saturated sand-gravel composites[J], Rock and Soil Mechanics, 2006, 27(6).
5. SUN Jing, YUAN Xiao-ming, SUN Rui. Reasonability comparison between recommended and code values of dynamic shear modulus and damping ratio of soils
6. Earthquake Engineering and Engineering Vibration, 2004, 24(2): 125 – 133.
7. BORDEN R H, SHAO L, GUPTA A. Dynamic properties of piedmont residual soils[J]. Journal of Geotechnical and Geoenvironmental Engineering, ASCE, 1996,
8. TOWHATA I, ISHIHARA K. Undrained strength of sand undergoing cyclic rotation of principal stress axes[J].
9. Soils and Foundations, JSSMFE, 1985, 25(2)

Influence of Subchronic Exposure of Profenofos on Biochemical Markers and Microelements in Testicular Tissue of Rats

Afaf A. El-Kashoury

Department Of Mammalian And Aquatic Toxicology, Central Agricultural Pesticides Laboratory, Agricultural Research Center, Giza, Egypt

ABSTRACT: To investigate the effect following subchronic exposure to the organophosphorous insecticide of common name profenofos, which extensively used in agriculture, on the key enzymes of fertility and the concentration of microelements in testicular tissues in male albino rats. **Methods:** Adult male albino rats were orally administered with profenofos at a dose of 23.14 mg/kg body weight per day for 60 days, emulsifying in 0.4 ml tap water. The control group received equal volume of tap water. Twenty-four hours after the last treatment the rats were sacrificed using anesthetic ether. Epididymus and testes were collected, cleaned and weight. Then epididymus prepared in buffer saline and spermatozoa were examined with light microscopy for concentration and motility. Testes were fractionated and supernatant of testicular homogenate was obtained by centrifugation, activities of alkaline and acid phosphatases, lactate dehydrogenase and total protein as well as concentration of microelements; Copper, Iron, Zinc and Selenium were measured. Moreover, the testes were histologically examined. **Results:** The epididymus and testes weights were significantly decreased. Reduction in sperm count was recorded in cauda epididymus in profenofos treated group, associated with decreased motility. Total protein (TP) level exhibited an elevation in testicular tissue in comparison with the control group. There was significant decrease in the activities of alkaline and acid phosphatase (ALP and ACP) and lactate dehydrogenase (LDH). A totally different trend was observed for the level of microelements; Copper (Cu), Zinc (Zn), Iron (Fe) and selenium (Se) where a sharp augmentation in the element levels was noticed in profenofos-treated rats compared with the control group. Treatment-dependent histopathological changes were seen in testes. **Conclusion:** Profenofos alters testicular functions possible by inhibition the activities of marker enzymes and inducing alteration in microelements levels, thereby disrupting male reproduction. [Journal of American 2009: 5(1), 19-28] (ISSN: 1545-1003)

Key words: Profenofos, Lactate dehydrogenase

1. INTRODUCTION

Organophosphorous insecticides (OPIs) have been considered as genuine alternatives to chlorinated (O'Ch) insecticides due to their broad-spectrum pesticidal properties and relatively shorter persistence after applications (Sharma et al., 2005). OPIs in addition to their intended effects like control of insects or other pests are sometimes found even to effect non-target organisms including human beings (Chantelli-Forti et al., 1993; Chaudhuri et al., 1999). Exposure to low level OPIs is known to produce a variety of biochemical changes, some of which may be responsible for the adverse biological effects reported in humans and experimental animals (Sutatos, 1994). There is growing concern that environmental chemicals both natural and man-made, having estrogenic property may be causing a variety of reproductive disorders in wildlife and human population (Chitra et al., 1999). The testes of humans and other mammals are highly susceptible to damage produced by genetic

disorders, environment or occupational exposure to chemical or other means. Specific causes of testicular damage have been catalogued (Jadaramkunti and Kaliwal, 2002). Mainly, much data are available about biochemical analysis of seminal plasma. However, not many studies have been conducted in animals yet (Pesch et al., 2006). Analysis of enzyme activities and concentrations of microelements can estimate integrity and function of testes, in man; analysis of seminal plasma enzymes and microelements has been performed accurately and much is known about the importance of the "right contents" of seminal plasma (Pandy et al., 1983; Chia et al., 2000; Huang et al., 2000 and Stanwell-Smith et al., 1983). It has been reported that, pesticides with such properties have been shown to cause overproduction of reactive oxygen species (ROS) in both intra and extra cellular spaces, resulting in a decline of sperm count and infertility in wildlife and human (Gangadharan et al., 2001).

Trace elements, such as Copper (Cu), Zinc (Zn), and Selenium (Se) have a pivotal role in the spermatogenesis (Homma-Taked et al., 2003). Ionic environment has a high influence on sperm function (Hamameh and Gatti, 1998), profenofos belongs to the phosphorothioate class of OPIs. It widely used for a variety of agricultural and public health applications, previous studies suggest that profenofos considered as one of the male reproductive toxicant (Moustafa et al., 2007). In spite of the extensive use of profenofos in crop protection and in the household, information related to its effects on health with particular reference to reproductive toxicity are scarcely. Therefore, the objective of this study was to clarify the effect following subchronic exposure to profenofos on testicular functions by measuring the fertility indices (sperm count and motility), the activity of specific enzymes that responsible of spermatogenesis (alkaline and acid phosphatases and lactate dehydrogenase) and total protein level as well as concentrations of the essential microelements; Copper (Cu), Iron (Fe), Zinc (Zn) and Selenium (Se) in testicular tissue of male rats.

2. MATERIALS AND METHODS

The active substance profenofos produced by Syngenta multi national comp. under trade name: Selecron 72% EC was used. Tap water was used for preparing emulsion of profenofos immediately before use and orally administered into animals by oesophageal intubation (per OS.). The median lethal dose (LD₅₀) of profenofos (per OS.) was determined according to Weil (1952) and its value was 185.13 mg/kg body weight.

In this investigation, thirty male Wistar albino rats, *rattus norvegicus* were obtained from the breeding unit of the Egyptian organization for the Biology and vaccine production, Egypt. Male rats initially weighing 150±10g were used. Animals were allowed to be acclimatized to laboratory conditions; of temperature at 25±2°C, humidity (30-70%) and light (12-h dark: 12-h light) and kept on balanced diet and water ad libitum for 2 weeks prior to the experiment. Animals were housed throughout the experiment in polypropylene cages (with each cage housing five animals) containing paddy husk as bedding.

2-3 Experimental Design. Rats were randomly divided into two comparable groups as follows,

First group: (n = 10) served as normal control and animals were received the vehicle (tap water). Second group: (n = 20) animals were orally dosed for 60 days with profenofos at 23.14 mg/kg body weight (4 doses/week). Clinical signs were monitored daily and animals were weighed twice weekly throughout the experiment and the dose was adjusted accordingly.

After completion of treatment period (60 days), animals were anaesthetized with ether and sacrificed. The testes and epididymus were removed immediately, cleaned of the adhering tissues and weighted. Fertility-related parameters (sperm count and motility) were performed by dissecting out the Cauda epididymus and teasing it in a known volume of normal saline at 37°C. Sperm counting was done using a haemocytometer according to the method of Feustan et al. (1989). The right testes were kept in a deep freezer (-40°C) for biochemical estimations and microelements detection. Left testes were removed and fixed in 10 % formalin for routine histopathology.

Frozen testes were washed with saline solution, then minced and homogenized (10% W/V) in ice-cold saline, using a chilled glass-teflon porter-Elvehjem tissue grinder tube. The homogenate was centrifuged at 10,000 xg for 20 min. at 4 °C and the resultant supernatant used for determination of protein contents, Tp (Bradford, 1976); alkaline phosphatase, ALP (Babson, 1965) and acid phosphatase ACP (Babson and Read, 1959). Also, a 10% homogenate of testes was prepared in ice-cold 0.1M phosphate buffer, the homogenate was centrifuged at 12,000 xg for 30 min. at 4°C. the supernatant used for determination of lactate dehydrogenase, LDH (Moss and Henderson, 1994).

For the histopathological observations at light microscopic level, fresh testes were immersion fixed in 10% formalin saline. Following an overnight fixation, the specimens were dehydrated in ascending grades of alcohol, cleared in benzene and embedded in paraffin wax. Blocks were made and 5µm thick sections were double stained with hematoxylin and eosin and observed under microscope (Banchraft et al., 1996).

The concentrations of the microelements Copper (Cu), Iron (Fe), Zinc (Zn) and Selenium (Se) in testicular tissues were measured according to the procedure which reported in AOAC (2004), by using atomic absorption spectrophotometer (Thermo Jarel Ash-AA-ScanI).

Data analysis and evaluation of statistical significance among different values determined was done using the student's t-test. Statistical

differences with a value of $p < 0.05$ were considered significant (Snedecor and Cochran, 1980).

3. RESULTS

The variations in the testes and epididymus weights of animals subjected to profenofos treatment are shown in Table (1). There was significant decrease ($p < 0.05$) and ($P < 0.001$) in weights of the testes and epididymus, respectively, as compared to control group.

Table 1
Effect of oral administration of profenofos on testes and epididymus weights of rats after sub-chronic exposure (60 days)

| Parameter | Control group | Profenofos-treated group 23.14 mg/kg body weight |
|-----------------------|-----------------|--|
| Testes weight (g) | 1.52 ± 0.040 | 1.40 ± 0.004* |
| Epididymus weight (g) | 0.37 ± 0.014 | 0.02 ± 0.008*** |

Data represent mean ± SE, n = 5, * P < 0.05, *** P < 0.001 (Student's t-test)

The effect of oral administration of profenofos for 60 days on sperm count and motility in cauda epididymus is shown in Table (2). The spermatozoal density (count) increased

significantly ($p < 0.05$) in profenofos-treated group in comparison with the control group. Similarly, spermatozoal motility was also found to be significantly decreased ($p < 0.001$).

Table 2
Effect of oral administration of profenofos on semen parameters in cauda epididymus of rats after sub-chronic exposure (60 days):

| Parameter | Control group | Profenofos-treated group 23.14 mg/kg body weight |
|---------------------------------|----------------|--|
| Total sperm count ($10^6/ml$) | 100 ± 3.536 | 80 ± 4.082* |
| Motility (%) | 90 ± 1.58 | 65 ± 3.227*** |

Data represent mean ± SE, n = 5, * P < 0.05, *** P < 0.001 (student's t-test)

Results of testicular biochemistry have been depicted in Table (3). Alkaline (ALP), acid (ACP) phosphatase and lactate dehydrogenas (LDH) activities were recorded to have decreased

($p < 0.001$, $p < 0.05$ and $p < 0.01$, respectively) in profenofos-treated group as compared to control group. In addition, total protein level was found to

be significantly raised ($p < 0.05$) in treated group in comparison with the control group.

Table 3
 Effect of oral administration of profenofos on some testicular biochemical parameters in rats after sub-chronic exposure (60 days)

| Parameters | Control group | Profenofos-treated group 23.14 mg/kg body weight |
|-------------------------------------|------------------|--|
| alkaline phosphatase (U/mg protein) | 0.127 ± 0.002 | 0.067 ± 0.009*** |
| acid phosphatase (U/mg protein) | 0.108 ± 0.002 | 0.084 ± 0.008* |
| lactate phosphatase (U/mg protein) | 1.60 ± 0.073 | 1.25 ± 0.042** |
| total protein (mg/g tissue) | 17.28 ± 0.774 | 20.27 ± 0.348* |

Data represent mean ± SE, n = 4, * P<0.05, ** P<0.01, *** P<0.001 (student's test)

In addition to the findings listed above, we have observed the presence of microscopic changes in the testes of male albino rats. Histological findings of testes from control and treated groups are presented in figs. 1, 2, respectively. Normal control animals, revealed normal mature seminiferous tubules with complete

series of spermatogenesis and high spermatozoal concentration in the lumen (fig.1) Profenofos-intoxicated animals indicated that there were few numbers of sperm cells in the lumen of the seminiferous tubules (fig. 2), in correlation with the control one.

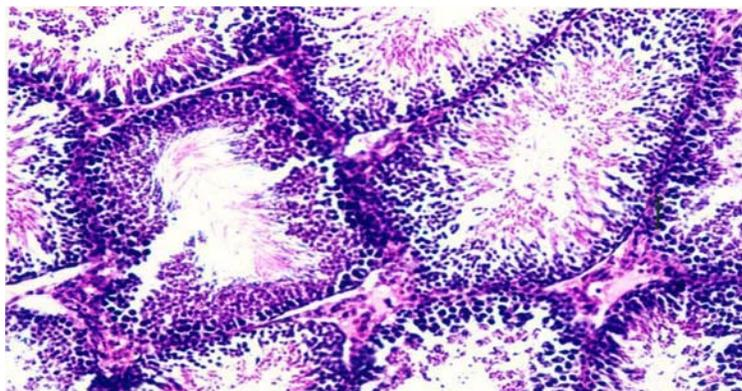

Fig 1: Testes of rat in control has shown the normal histological structure of the seminiferous tubules in nature active condition.

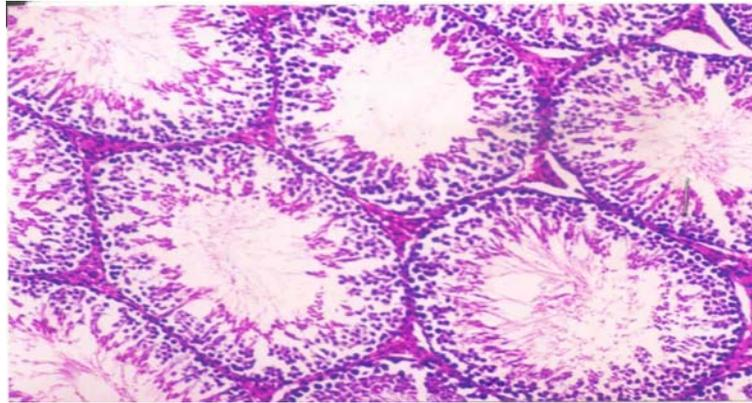

Fig 2: Testes of rat treated by profenofos showing low amount of sperms in the lumen of the seminiferous tubules.

Table 4
The Testicular tissue contents of microelements in profenofos-treated rats after sub-chronic exposure (60 days)

| Element (ppm) | Control group | Profenofos-treated group 23.14 mg/kg body weight |
|-------------------------|-------------------|--|
| Copper (mg/kg tissue) | 960.24 ± 3.136 | 1747.22 ± 3.747*** |
| Ferric (mg/kg tissue) | 370.36 ± 1.639 | 700.19 ± 4.827*** |
| Zinc (mg/kg tissue) | 9.93 ± 0.143 | 16.74 ± 0.138*** |
| Selenium (mg/kg tissue) | 100.52 ± 0.808 | 162.37 ± 0.438*** |

Data presented mean ± SE of five individual values.

The effect of oral administration of profenofos for the 60 days on testicular tissue contents of microelements is depicted in table (4). profenofos treatment produced significant increase ($p < 0.001$) in iron (Fe), copper (Cu), zinc (Zn) as well as in selenium (Se) levels.

4. DISCUSSION

Organophosphates (OPIs) are among the most widely used synthetic insect pesticides. The wide spread use of OPIs has stimulated research into the possible extent of effects related with their reproductive toxic activity (Joshi et al., 2007). The present study results demonstrated that 60 day's exposure of male rats to profenofos at the dose 23.14 mg/kg body weight (4 doses/week) resulted in decreased the testes and epididymus weights, male fertility indices (sperm count and motility), and activities of ALP, ACP and LDH but increased

levels of total protein and microelements (Cu, Fe, Zn and Se) in testicular tissues. Our results showed that the weights of testes and epididymus were significantly lower in the profenofos-treated rats than in the controls. The decrease in testicular weight in treated rats may be due to reduced tubule size, spermatogenic arrest and inhibition of steroid biosynthesis of leydig cells, a site of steroid biosynthesis (Sujatha et al., 2001 and Kaur and mangat, 1980). The decrease in testicular weight in profenofos-treated rats may indicate impairment at testicular, pituitary, or hypothalamic level (Chitra et al., 1991). Similar results were recorded by Ref Joshi et al. (2007), who mentioned that chlorpyrifos (OPIs) at dose levels of 7.5, 12.5 and 17.5 mg/kg b.wt./day, for 30 days, decreased significantly the weight of testes. The epididymus is androgen-dependant organ, relying on testosterone for its growth and function

(Klinefelter and Hess, 1998). On discussing the results with previous reports, it is proposed that profenofos probably impeded the activity of testes and epididymus by inhibition of androgen production or its direct action on these organs (Kaur and mangat, 1980), thus, the reduction in the weights of testes and epididymus in our study may be due to lower bioavailability of androgen (Sujatha et al. ,2001). Moreover, the deleterious effects of profenofos on reproductive organ weights might be due to a decrease in the testosterone (T) and thyroid hormone levels after 60 days from the onset of the treatment (Takizawa and Horii, 2002).

The present results confirm the previous reports of (El-kashoury and El-far, 2004) who mentioned that administration of rats with profenofos at 23.14 and 46.30 mg/kg body weight for 28 days and 60 days, respectively, induced significant decrease in thyroid hormone levels, there is ample evidence that thyroid hormone is essential to the normal development of testes in the neonate (Cook et al. ,1994 and Hardy et al. ,1996), as well as an elevation in cholesterol level, a precursor of steroid hormone had occurred. Authors also, mentioned that inhibition of hepatic microsomal 7-hydroxylation of cholesterol by profenofos leads to reduction of cholesterol break down and its accumulation. Sperm count is one of the most sensitive tests for spermatogenesis and it is highly correlated with fertility. Our results revealed that, treatment of rats with profenofos significantly reduced the sperm count and motility. The decreased sperm motility and density (count) after oral administration of profenofos is may be due to androgen insufficiency (Chaudhary and Joshi, 2003) which caused impairment in testicular functions by altering the activities of the enzymes responsible for spermatogenesis (Sinha et al. ,1995 and Reuber, 1981).

Histological structure of the testes confirmed the aforementioned results, where it is revealed degeneration in some of seminiferous tubules associated with low luminal spermatozoal concentration. It is tempting to speculate that the decreased sperm motility in the present study may have been related to our earlier studies on profenofos (El-kashoury and El-far, 2004) which pointed that subclinical hypothyroid state in rats administered with profenofos for 60 days had occurred. Also, men with hypothyroid have been reported to have lower sperm motility than euthyroid controls (Corrales – Hernandez et al.

,1990) and thyroxine (T4) replacement in men with hypothyroidism is reported to improve sperm motility (Kumar et al. 1990). Moreover, it had been reported that chlorpyrifos brought about marked reduction in epididymal and testicular sperm counts in exposed males (Joshi et al., 2007). Also, testicular atrophy and degenerative changes in the seminiferous tubules had been reported in experimental animals administered with various O'Ch and OPIs pesticides (Dutta and Dikshith, 1973). Based on the data obtained in this study, administration of profenofos into male albino rats reduced the activities of acid and alkaline phosphatase and lactate dehydrogenase which reflect suppression in testicular function (Johnson et al. ,1970). Activities of markers enzymes viz ALP, ACP and LDH are considered to be functional indicators of spermatogenesis.

Our results confirm the findings of (Salem et al. ,1989) who investigated the influence of methamidophos (O'ps) on mammals. Results showed that treatment of male rats with methamidophos, at 100 ppm in drinking water for 9 and 45 days, reduced significantly acid and alkaline phosphatase and lactate dehydrogenase in testicular tissue. Also, (Mustafa et al. ,2007) reported that profenofos considered as one of the male reproductive toxicants. ALP is primary of testicular and epididymal origin and, therefore, suitable for differentiation of oligo-and azoospermia (Turner and Sertich, 2001; Turner and McDonell, 2003). Decline in ALP activity indicated that profenofos treatment produced a state of decreased steroidogenesis where the inter and intercellular transport was reduced as the metabolic reactions to channelize the necessary inputs for steroidogenesis slowed down (Latchoumycandane et al. ,1997). Acid phosphatases are enzymes capable of hydrolyzing orthophosphoric acid esters in an acid medium. The testicular acid phosphatase gene is up-regulated by androgens and is down-regulated by estrogens (Yousef et al. ,2001). Activities of phosphatases enzymes have been shown to rise when testicular steroidogenesis is increased (Mathur and Chattopandhyay, 1982).

Also, (Latchoumycandane et al. ,1997) mentioned that a decrease in ACP activity in free state would thus reflect decreased testicular steroidogenesis in rats and this may be correlated with the reduced secretion of gonadotrophins. LDH is associated with the maturation of germinal

epithelial layer of seminiferous tubules and associated with post meiotic spermatogenic cells (Sinha et al., 1997). An inhibition in the activity of LDH in testes of profenofos-treated rats points toward the interference of profenofos with the energy metabolism in testicular tissues (Mollenhauer et al., 1990). The correlation between LDH and motility and living sperm could be a sign that extracellular LDH ensures metabolism of spermatozoa, perhaps even in anaerobic conditions (Pesch et al., 2006).

As regards the testicular protein, results of the present study exhibit an increase in its level in profefos-treated rats. The testicular fluid contains both stimulatory factors as well as inhibitory factors that selectivity alter the protein secretions (Brooks, 1983). Thus, the changes in protein suggested that there is a reduction in the synthetic activity in testes. An elevation in testicular protein in the present study confirms the previous results by (Joshi et al., 2007) who mentioned that the protein content was raised at significant levels in chlorphrifos-treated rats. Gupta et al. (1981) and Singh and Pandey (1989) illustrated that an elevation in the testicular protein may be due to the hepatic detoxification activities caused by endosulfan (O'ch) which results in the inhibitory effect on the activities of enzyme involved in the androgen biotransformation (Dikshith and Dutta, 1972).

Similar results showed the same trend in the protein content caused by several pesticides, at different periods and / or different concentrations, had been also reported (Shivanandappa and Krishnakumari (1981), Bhatnagar and Malviya, 1986; Chitra et al., 1999; Choudhary and Joshi, 2003). In accordance with the findings of the present study, Rao and Chinoy (1983), suggested that the accumulation of protein occurred in testes and epididymus due to androgen deprivation to target organs. This deprivation effect also led to a reduction in testicular and cauda epididymus sperm population, loss of motility in the latter and an increase in number of abnormal spermatozoa, thereby manifesting 100% failure in treated animals. Results of the present investigation showed that administration of profenofos into male rats increased the concentration of trace elements; Cu, Fe, Zn and Se in testicular tissue, which have a pivotal role in spermatogenesis (Homma-Takeda et al., 2007). These findings are not in accordance with those of Salem et al. (1989), who stated that treatment of rats with methamidophos (OPIs), for 45 days, decreased the concentrations of Zn and Se

in the testicular tissues. On the other hand, similar results were recorded by Al-Bayati et al. (1988), who mentioned that 2, 3, 7, 8-tetrachlorodibenzo-p-dioxin (TCDD), O'ch, produced atrophy, morphological changes and impaired spermatogenesis in testes of experimental animals. In addition, testicular tissue contents of Fe, Cu, and Zn were significantly increased in the treated rats. Zinc (Zn) markedly increased the ALP and ACP activities and this occurred concomitantly with the appearance of spermatids and mature sperm cells (Guha and Vanha-Perttula, 1983). Selenium is an essential trace nutrient for humans and animals. It is an essential at lower concentrations and toxic at higher concentrations. Se is required for normal testicular development and spermatogenesis in rats (Behne et al., 1996). The selenodeiodinase enzymes (types I, II and III iodothyronine deiodinase) control the metabolism of thyroid hormone, which is essential for the normal development (Defrance et al., 1995) and function (Latchoumycandane et al., 1997) of testes in rats. The above explanation supports our findings where elevated testicular tissue content of Se associated with decrease in testicular weight, sperm count and motility in profenofos-treated rats. In support of these findings, earlier results (El-Kashoury and El-Far, 2004) revealed that treatment of rats with profenofos at the same dose and time interval decreased markedly (T_3) level in plasma in comparison with the control group.

Copper is necessary for many enzymes like the Cu-Zn-Superoxide dismutase (SOD), which is involved in cell protection against free (Oxygen) radicals. Copper is also needed for the cytochrome C oxidase that is responsible for energy supply and for cellular and humoral immunity (Leonhard-Marek, 2001). As regards Cu concentrations, an administration of rats with profenofos increased testicular tissue contents of Cu by 2-fold, respectively. Elevated Cu concentrations reduced oxidative processes and glucolysis that may cause immotility and reduced viability (Leonhard-Marek, 2001). A proposed mechanism could explain elevated iron concentrations in testicular tissues in profenofos-treated rats, is that iron is known to be essential and mostly bound to transferrin (produced by sertoli cells), haptoglobin (sertoli, leydig and germ cells) and lactoferrin (spermatozoa and vascular gland). These proteins contain catalytic inactive iron which avoids extensive oxidation (Leonhard-Marek, 2001). Results of the present investigation suggested that profenofos may impede the utilization of micro-elements in the testes,

consequently stagnation of Cu, Fe, Zn and Se in the testes occurred. It is concluded that profenofos induced adverse effects on testicular function by altering biomarker enzymes activities as well as disrupting micro-elements levels, thus care should be taken and more studies should be done to increase the validity of those information.

Abbreviation used:

OPIs, organophosphorous insecticides; O'Ch, organochlorine, TP, total protein, ALP, alkaline phosphatase; ACP, acid phosphatase; LDH, lactate dehydrogenase; Cu, Copper; Zn, Zinc; Fe, Iron; Se, Selenium; Ec, Emulsifiable concentrate; T₄, Thyroxine; T₃, Triiodothyronine; T, Testosterone; Ros, Reactive oxygen species.

REFERENCES

1. A.O.A.C. (2004). Association of official analytical chemistry.
2. Al-Bayati, Z.A.; Wahab, Z.Z. and Stohs, S.J. (1988). 2, 3, 7, 8 Tetrachlorodibenzo-p-dioxin (TCDD)-induced alterations in lipid peroxidation, enzymes and divalent cations in rat testis. *Xenobiotica*. 18: 1281-1289.
3. Babson, A.L. and Ready, A.P. (1959). Colourimetric method for the determination of total and prostatic acid phosphatase. *Am. J. Clin. Path.*, 32 : 89-91.
4. Babson, L.A. (1965). Phenolphalein monophosphate methods for the determination of alkaline phosphatase. *Clin. Chem.*, 11 : 789.
5. Bancraft, J.D.; Stevens, A. and Turner, D.R. (1996). Theory and practice of histological techniques. 4th Ed., Churchill Livingstone, New York, London, San Francisco, Tokyo.
6. Behne, D.; Weiler, H. and Kyriakopoulos A. (1996). Effects of selenium deficiency on testicular morphology and function in rats. *J. Reprod Fertile*. 106: 291-297.
7. Bhatnagar, V.K. and Malviya, A.N. (1986). Changes in some biochemical indices in rat upon pesticide toxicity. *Indian J. Biochem. Biophys.*, 15 : 78-81.
8. Bradford, M.M. (1976). A rapid and sensitive method for the quantitation of microgram quantities of protein utilizing the principle of protein-dye binding. *Analyt. Biochem.*, 72 : 248-254.
9. Brooks, D.E. (1983). Effect of androgen on protein synthesis and secretion in various regions of the rat epididymis, as analysed by two dimensional gel electrophoresis. *Mol. Cell Endocrinol.*, 29 : 255-270.
10. Chanteli-Forti, G.; Paolini, M. and Hrelia, P. (1993). Multiple end point procedure to evaluate risk from pesticides. *Environ. Health perspect.* 101, 15-20.
11. Chaudhuri, K.; Selvaraj, S. and Pal, A. K. (1999). Studies on the genotoxicity of endosulfan in bacterial systems. *Mutat. Res.* 439, 63-67.
12. Chia, S.E.; Ong, C.N.; Chua, L.H.; Ho, L.M. and Tay, S.K. (2000). Comparison of zinc concentrations in blood and seminal plasma and the various sperm parameters between fertile and infertile men, *J Androl.* 21: 53-57.
13. Chitra, K.C.; Latchoumycandane, C. and Mathur, P.P. (1999). Chronic effect of endosulfan on the testicular functions of rat. *Asian J. Andrology*, 1 : 203-206.
14. Choudhary, N. and Joshi, S.C. (2003). Reproductive toxicity of endosulfan in male albino rats. *Bull. Environ. Contam. Toxicol.*, 70 : 285-289.
15. Cooke, P.S.; Zhao, Y.D. and Bunick, D. (1994). Triiodothyronine inhibits proliferation and stimulates differentiation of cultured neonatal sertoli cell: Possible mechanism for increase adult testis weight and sperm production induced by neonatal goitrogen treatment. *Biol. Reprod.* 51: 1000-1005.
16. Corrales-Hernandez, J.J.; Miralles-Gareia, J.M. and Garcia-Diez, L.C. (1990). Primary hypothyroidism and human spermatogenesis. *Arch. Androl.* 25: 21-27.
17. Defrance, L.R.; Hess, R.A.; Cooke, P.S. and Russell, L.D. (1995). Neonatal hypothyroidism causes delayed sertoli cell maturation in rats treated with propylthiouracin: Evidence that sertoli cell controls testis growth. *Anat. Rec.* 242: 57-69.
18. Dikshith, T.S.S. and Dutta, K.K. (1972). Pathological changes induced by pesticides in the testes and liver of rats. *Exp. Pathol.*, 7 : 309-316.
19. Dutta, K.K. and Dikshith, T.S.S. (1973). Histopathologic changes in the testes and liver of rats repeatedly exposed to pesticides. *Exp. Pathol.*, 8 : 363-370.
20. El-Kashoury, A.A. and El-Far, F.A. (2004). Effect of two products of profenofos on thyroid gland, lipid profile and plasma APO-1/FAS in adult male albino rats, Egypt. *J. Basic and Appl. Physiol.*, 3: 213-226.

21. Feustan, M.H.; Bodnai, K.R. and Kerstetter, S.L. (1989). Reproductive toxicity of 2-methoxy ethanol applied dermally to occluded and non-occluded sides in male rats. *Toxicol. Appl. Pharmacol.*, 100 : 145-165.
22. Gangadharan, B.; Murugan, M.A. and Mathur, P.P. (2001). Effect of methoxychlor on antioxidant system of goat epididymal sperm in vitro. *Asian J. Androl.*, 3 : 285-288.
23. Guha, K. and Vanha-Perttula, T. (1983). Acid phosphatases in the mouse testis: activity changes during development. *Arch-Anorl.* 10 (1): 7-16.
24. Gupta, P.K.; Shrivastava, S.C. and Ansari, R.A. (1981). Toxic effects of endosulfan on male reproductive organs in rats. *Indian J. Biochem. Biophys.*, 18 : 159-163.
25. Hamameh, S. and Gatti, J.L. (1992). Role of the ionic environment and internal pH on sperm activity, *Hum Repord Suppl.* 4: 20-30.
26. Hardy, M.P.; Sharma, R.S.; Arambepola, N.K.; Sottas, C.M.; Russell, L.D.; Bunick, D.; Hess, R.A. and Cooke, P.S. (1996). Increased proliferation of leydig cells induced by neonatal hypothyroidism in the rat. *J. Androl.* 17: 231-238.
27. Homma-Takeda, S.; Nishimura, Y.; Watanabe, Y. and Yukawa, M. (2007). Site-specific changes in zinc levels in the epididymus of rats exposed to ionizing radiation. *Nuclear instruments and methods in physics research section B. Beam interactions with materials and atoms.* 260: 236-239.
28. Huang, Y.L.; Tsen, W.C.; Cheng, S.Y. and Lin, T.H. (2000). Trace elements and lipid peroxydation in human seminal plasma, *Biol. Trace element.* 76: 207-215.
29. Jadaramkunti, U.C. and Kaliwal, B.B. (2002). Dicolofol formulation induced toxicity on tests and accessory reproductive organs in albino rats. *Bull. Environ. Contam. Toxicol.*, 69 : 741-748.
30. Johnson, A.D.; Gomes, M. and Vandemark, N.L. (1970). *The testis.* 1st Ed., Academic Press, New York and London.
31. Joshi, S.C.; Mathur, R.; Gilati and Tags, N. (2007). Testicular toxicity of chlorpyrifos (an organophosphate pesticide) in albino rat. *Toxicol Ind Health.* 23: 439-444.
32. Kaur, C. and Mangat, H.K. (1980). Effects of estradiol dipropionate on the biochemical composition of testes and accessory sex organs of adult rats. *Andrologia*, 12 (4) : 373-378.
33. Klinefelter, G.R. and Hess, R.A. (1998). Toxicology of the male excurrent ducts and accessory sex glands. In : *Reprod. and Dev. Toxicol.*, pp. 553-591, New York, Basel, Hong Kong; Marcel Dekker, Inc.
34. Kumar, B.J.; Khurana, M.L.; Ammini, A.C.; Karmarkar, M.G. and Ahuja, M.M.S. (1990). Reproductive endocrine functions in men with primary hypothyroidism: Effect of thyroxine replacement. *Horm. Res.* 34: 215-218.
35. Latchoumycandane, C.; Gupta, S.K. and Mathur, P.P. (1997). Inhibitory effects of hypothyroidism on the testicular functions of postnatal rats. *Biomed. Lett.*, 56 : 171-177.
36. Leonhard-Marek, S. (2001). Influence of drugs, pollution and trace elements on male fertility. In: Busch, W. and Holzmann, A. Editors, *Andrology in veterinary medicine*, Stuttgart, Schattauer, pp. 474-481.
37. Mathur, P.P. and Chattopadhyay, S. (1982). Involvement of lysosomal enzymes in flutamide-induced stimulation of rat testis. *Andrologia*, 14 : 171-176.
38. Mollenhauer, H.H.; Morre, D.J. and Rowe, L.D. (1990). Alteration of intracellular traffic by monensin : mechanism, specificity and relationship to toxicity. *Biochem. Biophys. Acta*, 1031 : 225-246.
39. Moss, D. W. and Handerson, A.R. (1994). *Lactate dehydrogenase 2nd Ed.*, Textbook of clinical chemistry, chapter 20, Enzymes, pp. 812-818
40. Moustafa, G.G.; Ibrahim, Z.S.; Hashimoto Y; Alkelch A.M.; Sakamoto K.Q.; Ishizuka M. and Fujita S. (2007). Testicular toxicity of profenofos in matured male rats. *Arch Toxicol.*
41. Pandey, V.K.; Parmeshwaran, M. and Soman, S.D. (1983). Concentrations of morphologically normal, motile spermatozoa: Mg, Ca and Zn in the semen of infertile men, *Sci Total Environ* 27: 49-52.
42. Pesch, S.; Bergmann, M. and Bostedt, H. (2006). Determination of some enzymes and macro-and microelements in stallion seminal plasma and their correlations to semen quality. *Theriogenology.* 66: 307-313.
43. Rao, M.V. and Chinoy, N.J. (1983). Effect of estradiol benzoate on reproductive organs and fertility in the male rat. *Eur. J. Obstet. Gynecol. Reprod. Biol.*, 15 (3) : 189-198.
44. Reuber, M.D. (1981). The role of toxicity in the carcinogenicity of endosulfan. *Sci. Total. Environ.*, 20 : 23-47.
45. Salem, H.A.; Younis, M.; El-Tohamy, M.; El-Herrawie, M.; Soliman, M. and Khalaf, A. (1989). Thyrotrophic and thyroid hormones concentration and some testicular biochemical parameters as affected by oral administration

- of methamidophs (Organophosphorus) into adult male rats. *J. Egypt. Vet. Med. Ass.* 49: 667-675.
46. Sharma, Y.; Bashir, S.; Irshad, M.; Nag, T.C. and Dogra, T.D. (2005). Dimethoate-induced effects on antioxidant status of liver and brain of rats following subchronic exposure. *Toxicology*, 215 : 173-181.
47. Shivanandappa, T. and Krishnakumari, M.K. (1981). Histochemical and biochemical changes in rats fed dietary Benzene hexachloride. *Indian J. Exp.*, 19 : 1163-1168.
48. Singh, S.K. and Pandey, R.S. (1989). Differential effects of chronic endosulfan exposure to male rats in relation to hepatic drug metabolism and androgen biotransformation. *Indian J. Biochem. Biophys.*, 26 : 262-267.
49. Sinha, N.; Narayan, R. and Saxena, D.K. (1997). Effect of endosulfan on the testes of growing rats. *Bull. Environ. Contam. Toxicol.*, 58 : 79-86.
50. Sinha, N.; Narayan, R.; Shanker, R. and Saxena, D.K. (1995). Endosulfan-induced biochemical changes in the testis of rats. *Vet. Hum. Toxicol.*, 37 (6) : 547-549.
51. Snedecor, G.W. and Cochran, W.G. (1980). *Statistical methods* (7th ed). Iowa State University Press. Ames.
52. Stanwell-Smith, R.; Thompson, S.G.; Haines, A.P.; Ward, R.J. Cashmore, G. and Stedronska, J. (1983). A comparative study of zinc, copper, cadmium and lead levels in fertile and infertile men, *Fertile Steril.* 40: 670-677.
53. Sujatha, R.; Chitra, K.C.; Latchoumycandane, C. and Mathur, P.P. (2001). Effect of lindane on testicular antioxidant system and steroidogenic enzymes in adult rats. *Asian J. Androl.*, 3 : 135-138.
54. Sultatos, L.G.(1994). Mammalian toxicity of organophosphorus pesticides. *J. Toxicol. Environ. Health* 43, 271-289.
55. Takizawa, S. and Horii, I. (2002). Endocrinological assessment of toxic effects on the male reproductive system in rats treated with 5-fluorouracil for 2 or 4 weeks. *J. Toxicol. Sci.*, 27 (1) : 49-56.
56. Turner, R.M. and McDonnell, S.M. (2003). Alkaline phosphatase in stallion semen : characterization and clinical applications. *Theriogenology*, 60 : 1-10.
57. Turner, R.M. and Sertich, P.L. (2001). Use of alkaline phosphatase activity as a diagnostic tool in stallions with a zoospermia and oligospermia. *Anim. Reprod. Sci.*, 68 : 315-316.
58. Weil, C.S. (1952). Tables for convenient calculation of medium effective (LD50 or EC50) and instruction in their use. *Biometrics*, 8 : 249-263.
59. Yousef, G.M.; Diamandis, M.; Jung, K. and Eleftherios, P. (2001). Molecular cloning of a novel human acid phosphatase gene that is highly expressed in the testes. *Genomics*, 74 (3) : 385-395.

Research Article

Effect of Duckweed Meal on The Rate of Mold Infestation In Stored Pelleted Fish Feed

¹B.N. Effiong, ²A. Sanni,

¹Dept of Fisheries Technology, Federal College of Freshwater Fisheries Technology
New Bussa, Nigeria.

²Dept of Microbiology, University of Ilorin, Nigeria.

ABSTRACT: The effect of duckweed (*Lemna pauciscostata*) meal on the rate of mould infestation in stored pelleted fish feed was carried out. Freshly harvested duckweed was dried and thoroughly ground into powder using a milling machine. Five dry fish feeds were then prepared using duckweed as a replacement for fishmeal at 0%, 10%, 20% and 30% respectively at 40% crude protein, a diet for catfishes. The resultant pelleted feeds were sun dried for 24hrs and stored in airtight polyethylene bags at room temperature. Quantitative mold count using direct colony counts on pour plate technique with 24hr old culture was carried out bi-weekly until profuse growth were recorded within 24hrs in all experimental feeds. Results showed that mold count from experimental feeds decreased with increasing concentration of duckweed. Ethanolic extracts also showed higher inhibitory properties on radial mycelial growth of all the isolates. Isolates identified were *Fusarium oxysporium*, *Penicillium digitatum*, *Aspergillus niger*, *A.fumigatus*, *A..flavus*, *Rhizopus stolonifer* and *R..oryzae*. [Journal of American Science 2009: 5(1), 29-34] (ISSN: 1545-1003)

Key words: Polyethylene, *Fusarium oxysporium*

1. INTRODUCTION

Feeds are a major cost input into the aquaculture industry and their insufficiency is prominent among the factors responsible for inadequate aquacultural production of fish.

Compounded feeds are prepared with biologically decomposable materials. These materials decompose while in storage due to environmental factors such as temperature and humidity. Change in temperature and humidity affects the moisture content of compounded feed as well as the rate at which chemical changes takes place thereby enhancing invasion and growth of fungi in the feed (Sena and Anderson, 1995; Effiong and Eyo, 1999). Recontamination of feedstuffs by adventitious microorganisms during storage is of primary concern to the feed processor.

Moulds are the principal spoilers of feedstuff in storage (Chow, 1980). Moulds infestation reduces the nutritional value of feeds through loss of dietary lipids and amino acids (Jones, 1987). They also produce mycotoxins, which cause staleness of feed. He also stated that there is no effective way of eliminating fungal growth in stored pelleted feed. Their growth can only be controlled. Research work on the problems of storage of feedstuff \feed has been rather scanty

despite the enormous harmful effect it poses on the development of aquaculture in Nigeria (Effiong and Eyo, 2001). Duckweed meal has been reported to resist attacks by mould for more than 5 years (Skillicorn et al., 1993). Duckweed meal is the compounded form of the group of aquatic macrophytes from the family Lemnaceae. The dried powdered and directly pelleted forms of this plant have been observed in storage for 13 years without any signs of fungal growth or physical damage, retaining its nutrient content (Mbagwu, 2001). This study is therefore aimed at determining the effect of duckweed meal on the rate of mould infestation in stored pelleted fish feeds.

2. MATERIALS AND METHODS

Freshly harvested duckweed was thoroughly rinsed with clean water and evenly spread on a mosquito net-size mesh outside to sundry and thereafter dried in a forced air oven at 165 °c for 48 hours and ground to powder with a milling machine according to Mbagwu and Adeniji (1987). Five dry diets were prepared in which fish meal was replaced with duckweed at 0%, 10%, 20% and 30% levels using the method of Akegbejo Samson (1999) at 40% crude protein, a diet for catfishes. The various feed ingredients were thoroughly

ground into fine meal and mixed together with vitamin premix and salt using hot water.

The resultant mixture was pelleted with Moulineuse HV6 model pelleting machine and sun dried for 24 hours. The diets were stored in airtight containers at room temperature for 2 weeks. 1.0g of each feed sample were ground using pestle and mortar, to prepare 10-fold serial dilution. Agar was prepared using sterilized glasswares according to manufacturer's instruction and autoclaved at 121 °c for 15 minutes. It was allowed to cool to about 37 °c before 1% streptomycin was added to prevent bacterial contamination (Nwachukwu, 1988). A 48hour old culture of the isolates were subcultured and incubated at room temperature to produce pure cultures from which stock were prepared and stored. A bi-weekly mould count from each experimental diet was carried out quantitatively using direct colony count on pour plate technique (Miles and Misra, 1938) with 24-hour-old culture. Enumeration continued until profuse growth was recorded within 24 hours in all the experimental diets. Mould isolates were characterized during sporulation on the basis of cultural and morphological characteristics as well as microscopic examination (Samson and Reenen-Hoekstra, 1988). Sample of duckweed meal was ground using an Automatic Weed Grinder after it was thoroughly washed and air-dried. 5g of this each was measured and blended with 25ml of sterile distilled water (Oyagade, 1994). After thoroughly blending for 7 minutes, the slurry was filtered through a four-layered muslin cloth. The filtrate was passed through a 0.48 millimicron Millipore filter and transferred into sterile bottle. In order to compare the efficiency of the extraction process, 95 % alcohol was used as the comparative solvent using the same method.

Radial mycelial growth inhibition tests were carried out on the isolates (Van-Etten, 1973; Oloke et al., 1988). The extracts were separately incorporated into molten PDA at 18ml of media to 2ml of extract. Control plates had either sterile water or ethanol without extract.

Agar- extract mixtures were poured into sterile glass petri dishes and allowed to set (Adedayo, 1994). Mycelial plugs of the test organisms of 5.0mm diameter were cut using sterile cork-borer from the advancing margin of the fungal colonies. These were placed at the center of PDA containing concentrations of 5% sterile distilled water or ethanol. All plates were incubated at 25 °c and radial mycelial growth recorded for 72 hours at 24 hours interval

3. RESULTS AND DISCUSSION.

The bi-weekly fungal count (cfu) from the experimental feed at varying concentrations of duckweed showed decrease in fungal growth with increasing concentration of duckweed (Table 1). This observation could be attributed to the antifungal properties of duckweed acting against the growth of fungal species in the feed. Skillicorn et al., (1993) attributed the long storage characteristic of duckweed meal to the presence of high levels of wax. It could be possible that wax presents physical barriers to the growth of molds, which might impair their utilization of nutrients in the feeds. The molds isolates from the experimental feed samples were *Fusarium oxysporium*, *Penicillium digitatum*, *Aspergillus niger*, *A. fumigatus*, *A. flavus*, *Rhizopus stolonifer* and *R. oryzae*. Chow (1980) reported that the most common molds involved in the spoilage of feedstuffs belong to the *Aspergillus* and *Penicillium* species among others. The presence of *Aspergillus flavus* from the feed indicates the possibility of mycotoxins, compounds produced by this species that are toxic to both humans and fish. Feedstuffs known to be contaminated by *A. flavus* include groundnut cake, maize, sorghum, cottonseed cake, copra and cassava (Chow, 1980). The same author however reported that for aflatoxins to be produced, *A. flavus* must be present alone in a practically pure culture and that the presence of other molds, yeast or even bacteria seems to interfere with aflatoxin production. These findings have also been reported by Abdulhamid (2008).

The effect of duckweed extracts on the radial mycelial growth of fungal isolates from the experimental feeds is shown in Table 2. Differential efficacy on the test organisms was observed between the aqueous and ethanolic extracts of duckweed meal. Ethanol appeared better as an extractant judging from the wider activity spectrum and the resultant effect on the isolates. This observation perhaps suggests the possibility of the occurrence of bioactive substances that are not only soluble in water but also in organic solvent in the plant material. Majekodunmi et al., (1996), and Martinez et al., (1996) reported that a higher activity of extractable natural products were obtained in ethanol compared with aqueous extracts. Odemena and Essien (1995) also reported that the bacterial activity of alcoholic extracts of the roots of fluted pumpkin, *Telfaria occidentalis* was better than that of aqueous extracts. Natarajan et al., (2005) reported the antifungal properties of three

medicinal plant extracts against *Cercospora arachidicola*. They reported that fungal growth was gradually suppressed with increasing extract concentration. Similar findings have been reported by Lucia et al., (2002), Silva et al., (2001) and Costa et al., (2000). These reports are similar to the findings of this study. Olafimihan (2003) working on the antibacterial properties of aqueous and ethanolic extracts of Neem plant reported that the antibacterial activity of the concentrated extract increased with increase in its concentration. This report is similar to the findings from this study with the observation that increasing concentration of duckweed meal in experimental feed resulted in decreasing fungal growth.

The environmental conditions of temperature and relative humidity during the period of the study were high and fell within the ranges that support luxuriant growth of molds in the experimental feed sample. The temperature range varied between 27.2 and 30.6 °C while

relative humidity remained constant between 79 and 80%. According to Chow (1980), growth of fungi is only possible at temperature above 25°C and relative humidity values at 65%. There any reduction in fungal growth in the experimental feeds could not be attributed to directly affect the rate of fungal infestation of compounded feed in storage.

4. CONCLUSION

The results obtained from this study indicate reduced growth performance in the fungal species isolated from the experimental feed which also signified low infestation rate. Fungal growth decreased generally with increase in concentration of duckweed meal in feed samples.

The result of this experiment have shown that duckweed has the potential of being a beneficial agent for the control of fungal growth in compounded feed in storage.

Table 1
 Percentage composition of experimental feed with different inclusion levels of duckweed meal

| Ingredients (g) | 0% | 10% | 20% | 30% |
|------------------------|-----------|------------|------------|------------|
| Duckweed | 0 | 2.6 | 5.2 | 7.8 |
| Fish meal | 26 | 33.4 | 20.8 | 18.2 |
| Yellow maize | 48 | 48 | 48 | 48 |
| Soya Bean meal | 15 | 15 | 15 | 15 |
| Groundnut cake | 6 | 6 | 6 | 6 |
| Vitamin premix | 2 | 2 | 2 | 2 |
| Bone meal | 2.5 | 2.5 | 2.5 | 2.5 |
| Salt | 0.5 | 0.5 | 0.5 | 0.5 |
| Total | 100 | 100 | 100 | 100 |

Table 2
 Bi- weekly fungal counts at varying concentrations
 of duckweed in experimental feed.

| Concentration of Duckweed (%). | Fungal count (cfu/ml)(x 10 ⁷) | | | | | | | |
|---|---|----|----|----|----|---------|---------|---------|
| | Time (wk) | | | | | | | |
| | 2 | 4 | 6 | 8 | 10 | 12 | 14 | 16 |
| 0 | 12 | 20 | 31 | 43 | 72 | Profuse | Profuse | Profuse |
| 10 | 5 | 9 | 21 | 35 | 52 | 108 | Profuse | Profuse |
| 20 | 3 | 11 | 18 | 27 | 48 | 90 | Profuse | Profuse |
| 30 | - | - | 9 | 16 | 21 | 54 | 76 | Profuse |

Table 3
 Effect of duckweed extracts on the radial mycelial growth of fungal isolates

| Test Organism | Mycelial growth (mm) | | | | | |
|------------------------------|----------------------|----|-----|--------------------|----|-----|
| | Aqueous Extract | | | Ethanollic Extract | | |
| | 0% | 5% | 10% | 0% | 5% | 10% |
| <i>Fusarium oxysporium</i> | 46 | 21 | 10 | 10 | - | - |
| <i>Penicillium digitatum</i> | 50 | 35 | 24 | 9 | 5 | - |
| <i>Aspergillus niger</i> | 47 | 27 | 18 | 16 | 7 | 2 |
| <i>Aspergillus fumigatus</i> | 38 | 18 | 12 | 4 | - | - |
| <i>Aspergillus flavus</i> | 50 | 38 | 20 | 16 | - | - |
| <i>Rhizopus oryzae</i> | 36 | 29 | 16 | 14 | - | - |
| <i>Rhizopus stolonifer</i> | 42 | 21 | 13 | 22 | 10 | 4 |

Table 4
Proximate composition of experimental feed with different inclusion level of duckweed

| Feed Sample | % Crude protein | %Ether extract | %Ash content | %Moisture content | %Crude fibre |
|-------------|-----------------|----------------|--------------|-------------------|--------------|
| 0% | 43.35 | 14.02 | 12.30 | 1.00 | 6.50 |
| 10% | 42.56 | 14.29 | 12.00 | 1.00 | 4.46 |
| 20% | 41.87 | 12.83 | 11.90 | 2.00 | 5.13 |
| 30% | 45.06 | 11.76 | 13.29 | 2.00 | 4.90 |

REFERENCES

1. Abdulhamid, A.M (2008). Mycotoxicoses in fish with special emphasis on the Egyptian Situation.E:\nicotoxins in feeds.htm.
2. Akegbejo-Samson,Y (1999). Growth response and nutrient digestibility by *Clarias gariepinus* fed varying levels of dietary periwinkles flesh as replacement for fishmeal in low cost diets. Journal of Applied Trop.Agriculture.Vol.4 (1) 37-41.
3. Adedayo, O and Kolawale, P.O (1994). Resistance of mouse-virulent encapsulated nasal isolates of *Staphylococcus aureus* to disinfectant and antiseptics. Biomedical Letters. (50) 151-156.
4. Chow, K.W (1980). Storage problems of feedstuffs. Fish Feed Technology.ADCP/REFP\80\11,UNDP/FAO, Rome 215-224.
5. Costa, T.R; Fernandes, O.F.L; Santos,S.C; Oliveira, C.MA; Liao,L.M; Ferri,P.H; Paula,J.R.P; Ferreira,H.D; Sales,H.N and Silva,M.R.R (2000). Antifungal activity of volatile constituents of *Eugenia dysenterica* leaf oil. J. of Ethnopharmacol.72:11-117.
6. Effiong, B.N and Eyo, A.A (2001). Quality deterioration of feeds and feedstuff in storage-A review. Fish nutrition and Fish Feed Technology.ISBN 978-177-046-5 Pp113-121.
7. Effiong, B.N and Eyo,A.A (1999).Control of mould infestation in stored pelleted feeds. Proceedings of the 12th Annual Conference of Biotechnology Society of Nigeria.Pp111-114.
8. Jones, F. (1987). Controlling mould growth in feeds. Feeds International.8: 20-29.
9. Lucia,K.H.S;Cecilia, A.Pedro, N.Suzana,C.S, Judasio,G.DO; Andre,T.B.M; Luciano,M.L and Maria,R.R Silva (2002). Antifungal properties of Brazilian Cerrado plant. Braz. J. Microbiology. Vol.33 (3) 102-107.
10. Mbagwu,I.G and Adeniji,H.A(1988).The nutritional content of duckweed (*Lemna pauciscostata* Hegelm) in the Kainji Lake area, Nigeria. Aquatic Botany. (29) 357-366.
11. Mbagwu, I.G (2001). The effect of long-term storage on the nutrient characteristics of Duckweed (*Lemna pauciscostata* Hegelm). J.Arid Agric. (11) 147-149.
12. Miles, A.A and Misra, S.S (1938). Estimation of bactericidal power of blood. J. Hyg (38) 732-749.
13. Nwachukwu, C.O (1988). Microbiology of Pepper (*C.annum*) and the efficacy of some local methods of preservation. M.Sc Thesis. Biological Sciences.UniIlorin.
14. Natajaran,D; Srinivasan,K; Mohanasundari,C; Perumal,G; Dheen, M.A.N;Ganapathi,G.A and Rajarajan,T. (2005).Antifungal properties of three medicinal plant extracts against *cercospora arachidicola*. Advances in plant Sciences Vol.18 (1) 45-47.

15. Odemena, C.S and Essien, J.P (1995). Antibacterial activity of the root extract of *Telfera occidentalis* (Fluted Pumpkin). West African Journal of Biological and Applied Chemistry 40(1-4): 29-32.
16. Oloke, J.K; Kolawole, D.O and Erhun, W.O (1988). The antimicrobial and antifungal activities of certain components of *Aframonium meleguets* fruits. Fitoterapia 59(5)384-388.
17. Oyagade, J.O (1994) Antimicrobial efficacy of stem bark extracts of two Nigerian medicinal plants, *Terminalia glaucescens* (Planch) and *Entada africana* (Guill and Perr.) Ph.D Thesis, Biological Sciences, UniIlorin, Nigeria.
18. Olafimihan, C.A (2003). Studies on the antibacterial properties of aqueous and alcoholic extracts of the neem plant (*Azadirachta indica*. A.Juss) Ph.D Thesis. UniIlorin, Nigeria.
19. Sena, S.S and Anderson, T.A (1995). Fish Nutrition in Aquaculture. Chapman and Hall Aquaculture Series. 1st Edition. Chapman and Hall, 2-6 Boundary Row, London SE118HN.
20. Skillicorn, P; Spirar, W; and Journey, W (1993). Duckweed Aquaculture. A New Aquatic Farming System for developing countries. A World Bank Publication. National Agricultural Research Project (NARP), Nigeria. 309Pp.
21. Van-Etten, H.D (1973). Differential Sensitivity of fungi to Pistat and Phaseolin. Phytochemistry (63) 1477-1482.

Research Article

Distribution and Sources of Organochlorine Pesticides (OCPs) in Karst Cave, Guilin, China

*Annette Sylvie Muhayimana, *Qi Shihua, Wang Yinghui

Kong Xiangsheng¹, Odhiambo Joshua Owago, Zhang Junpeng

Department of Environmental Engineering, Faculty of Environmental Studies,

Key Laboratory of Bio and Environmental Geology of Ministry of Education, China University of Geosciences, Wuhan, Hubei 430074, China

E-mail: teteli2001@yahoo.com

ABSTRACT: Despite the numerous researches done on Organochlorine pesticides (OCPs) in China and in the world, information regarding emissions and concentrations of OCPs in Karst caves is extremely limited. Karst areas have much higher ecological vulnerability and are so easy to be contaminated. This paper presents results of a monitoring program conducted in Dayan cave, Guilin, China that was designed to characterize levels, trends and sources of pesticides in soil (sediment) samples. Thirteen soil samples were collected and OCPs were analysed. Inside the cave a total concentration of OCPs (Σ OCPs) detected was 29.659 ng/g with a mean value of 3.295 ng/g and Σ OCPs detected outside the cave was 74.108 ng/g with a mean value of 18.527ng/g. Σ OCPs outside the cave was higher than Σ OCPs inside the cave. The concentration of Chlordane in OCPs was highest among all the OCPs detected with range of 0.12–13.253ng/g and mean value of 3.93 ng/g. The next compound with high level of concentration was Heptachlor which ranged from Non-detected (ND) to 2.465 ng/g with a mean value of 1.4 ng/g. The pollution of OCPs in soil comparing with other countries and other areas in China was light. The analysis of Dichlorodiphenyltrichloroethane (DDT) and Hexachlorocyclohexane (HCH) isomers showed that there was fresh input of Dicofol and Lindane in the study area. By calculating the ratios of Dichlorodiphenyldichloroethane (DDD) to Dichlorodiphenyldichloroethylene (DDE), it was found that the degradation of DDT outside the cave was aerobic and the degradation of DDT inside the cave was anaerobic. [Journal of American Science 2009: 5(1), 35-43] (ISSN: 1545-1003)

Key words: Organochlorine Pesticides, Karst Cave

1. INTRODUCTION

Organochlorine pesticides are a group of persistent organic pollutants (POPs) which are to be eliminated or reduced on their release into the environment in many countries. Because of their persistence in the environment, and biological accumulation through the food web, OCPs can cause environmental damage, and affect human health (Colborn et al, 1996). Due to their volatility and persistence in the air; OCPs are subjected to long-range atmospheric transport (LRAT). Therefore, OCPs released in the tropical and subtropical environments could be dispersed rapidly through air and water, and tend to be redistributed on a global scale (Tanabe, 1991). The origin and fate of OCPs in soils with different land use have been extensively studied in many countries. Although the usage of OCPs was phased out for decades, the elevated concentrations were still observed in many agricultural soils (Harris et al., 2000) and the relationship between sites of

greatest application and current residue levels was found strong (Shivaramaiah et al., 2002). The release of OCPs from soils continues to be a source of OCPs pollution to the environment (Meijer et al., 2001).

China is a large producer and consumer of Pesticides in the world (Rongbing et al., 2006). Large amount of OCPs were used in past decades to sustain over population in China. HCH and DDT were widely used in China from 1952-1983. Although their use had been discontinued in China since 1983, their persistence has left residual amounts in the soil in many areas (Zhao Ling and Ma Yongjun, 2001). At present the use of DDT is still allowed to control mosquitoes, particularly in the malarial transmission zones in China (Zhang et al., 2005). Accordingly, China still produces a small amount of DDT and China is also allowed to export DDT to other countries for the same

purpose. This paper presents the current status of OCPs residues in Dayan cave (Karst cave).

2. MATERIALS AND METHODS

2.1 Study Area

Region of research was in Guilin located in Guangxi Zhuang Autonomous Region in southeast China. Guangxi province (Southeast of China). The Geographical coordinates are 25° 40' 25" North, 108° 44' 0" East and has an altitude of 150m. It is bounded to the north-east by Hunan province, to the south-east by Hezhou town and it is next to Guangdong province. It has a surface area of 27, 800 square kilometers and a population of 4.76 million.

Dayan is an intermediate upper layer cave of Guilin Maomoatou cave system, located in the

middle part of Guangming Mountain at right side of Taohua River in the north-west of Guilin. Guangming Mountain is a large peak cluster in Fenglin Plain, with an area of 0.92km², the highest peak altitude of 404.4m and the plain altitude of 151 m. The outcrop is a thick limestone layer of the Devonian system with a high intensity of Karst process. Dayan is a noncommercial karst cave located northeast to Ludiyan cave. The map of Guangxi showing Guilin and plane diagram of Dayan cave are shown in Fig 1 and Fig 2 respectively.



Fig 1: Map of Guangxi province showing Guilin

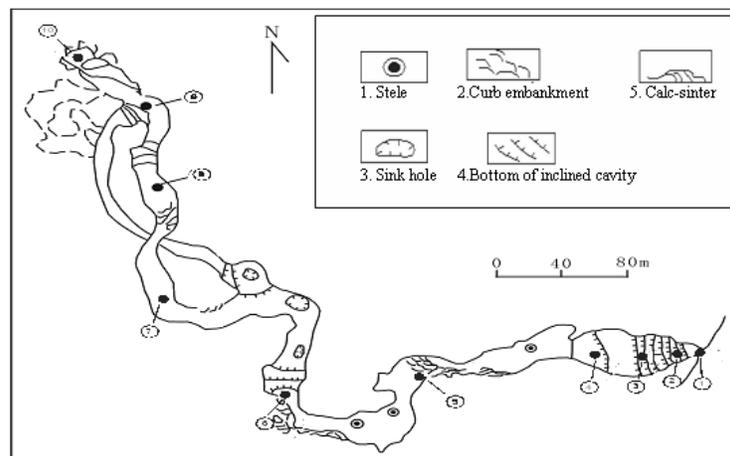

Fig 2: Map of Dayan Cave showing sampling locations (1 to 10) are sampling locations

2.2 Soil sampling

Ten sampling locations were chosen inside the cave that followed the horizontal section from the east gate as shown in Fig 2. Sampling location 1 was at the east gate (outside the cave) and the serial number was from 1 to 10. Three samples (1', 2', and 3') were also taken outside the east gate. Nine samples were obtained inside the cave (2 to 10) and 4 samples outside the cave (1, 1', 2', and 3'). Sampling was done with the use of a hand shovel. The weight of each sample collected was 500g. After the collection of samples, they were kept frozen prior to the commencement of the laboratory analysis.

2.3 Analysis

2.3.1 Experimental procedures

Before analysing the samples (before experiment) all glass wares were acid washed and cleansed with distilled water before they were dried in the oven at 200°C for about four hours. Reagents used for the experiment included: dichloromethane (DCM), hexane, acetone, sodium sulfate, alumina gel (100-200 mesh), silica gel (100-200 mesh), mesh hydrochloric acid and vitriol. Filter paper, aluminium foil, absorbent cotton and active copper were also used as materials.

Mixed standard sample of OCPs [2,4,5,6-tetrachloro-m-xylene (TCMX) and decachlorobiphenyl (PCB 209)] were used as surrogate standards and were added to all the samples before the extraction. The whole process of pretreatment was based on US EPA SW-8080A method as reference. 20 g of the sample were weighed with electronic balance and injected with the surrogate (using a syringe) before the sample was Soxhlet-extracted for 48 hours with redistilled Dichloromethane (DCM). Active copper slices were added to the conical flask containing DCM to eliminate the influence of sulphur contained in the sample. After 48 hrs in the Soxhlet extractor, the extracted samples were added with Sodium sulphate (Na_2SO_4) to remove unwanted water. After that, the solvents were concentrated to about 5 ml and then passed through a mixture of silica gel and alumina gel (10/3, V/V) for purification and it was rinsed by a mixture of DCM and hexane (2/3, V/V). The solvent was then condensed with high purity Nitrogen. 4 ml of the hexamethyl-benzene and PCNB (5ppb) were added as internal standards to help in quantifying the amount of OCPs present in the samples. Finally samples were stored and kept

in the refrigerator until next analysis (Analysis by HP 6890 GC).

2.3.2 Analysis by HP 6890 GC

HP 6890 GC (Gas Chromatography) was equipped with a ^{63}Ni electron capture detector and a 30 m x 0.32 mm i.d (0.25 μm film thickness) DB-5 fused silica capillary column. Nitrogen was added as a carrier gas at 1.2ml/min. the oven temperature was kept at 40°C for 5 minutes and increased to 290°C at a rate of 4°C/min. Injector and detector temperatures were maintained at 250 and 300°C respectively. 2 Microliters (μl) of each sample was injected for analysis.

2.3.3 Quality control and Quality assurance (QC/QA)

Quality control and Quality assurance was made by the use of the US EPA method in the process of the experiment. Method blanks (solvents), duplicate samples, and spiked blanks (standards spiked into solvent) were analyzed. In addition, surrogate standards were added to each of the samples to monitor procedural performance and matrix effects. The concentrations of OCPs were corrected for the recovery ratios for the surrogates. The recovery ratios for the surrogates in the samples conform to the reported ranges by US EPA. The recovery rates and standard deviation of OCPs during separation and testing are within the limiting value of the US EPA 610 method. Recovery rates of TCMX and PCB209 are 69±6% and 76±7% respectively.

3. RESULTS AND DISCUSSIONS

3.1 Concentration and distribution of OCPs

A summary of concentrations of OCPs detected in soil samples of Dayan cave is shown in Table 1. Inside the cave $\sum\text{OCPs}$ detected was 29.659 ng /g with a mean value of 3.295 ng /g and $\sum\text{OCPs}$ detected outside the cave was 74.108 ng /g with a mean value of 18.527ng/g. $\sum\text{OCPs}$ outside the cave is higher than the total concentration outside the cave (Fig 3).

The levels of OCPs outside the cave compared to the levels inside indicated that despite the relatively closed environmental system of the cave and less human interference inside the cave, it still had OCPs contamination due to air transfer, rain water filtration and other processes, but the degree of contamination was not high.

Table 1
Levels of OCPs in soil samples of Dayan Cave

| | OCPs overall level range | OCPs level range inside the | OCPs level range outside |
|----------------------------|--------------------------|--|--|
| | Min—Max(mean value) | cave Min—Max(mean value) (2 to 10 samples) | the cave Min—Max(mean value) (1, 1', 2', 3' samples) |
| α -HCH | 0.014—0.170 (0.087) | 0.014—0.126(0.043) | 0.095—0.170(0.130) |
| β -HCH | 0.026—0.219 (0.102) | 0.026—0.219(0.087) | 0.100—0.138(0.117) |
| γ -HCH | 0.015—0.285 (0.092) | 0.015-0.180(0.044) | 0.075—0.285(0.140) |
| δ -HCH | 0.009—0.072 (0.034) | 0.009—0.045(0.024) | 0.020—0.072(0.044) |
| TC | 0.021—6.119 (1.841) | 0.021—1.674(0.279) | 3.226—6.119(3.403) |
| CC | 0.085—7.134 (2.221) | 0.101—3.111(0.849) | 3.899—7.134(4.198) |
| Hep | ND—2.465 (1.399) | ND—1.087(0.139) | 1.871—2.465(1.632) |
| Hep-Epo | ND—1.908 (0.911) | ND—1.022(0.379) | 1.000—1.908(1.185) |
| EndoI | ND—0.230 (0.067) | ND—0.040(0.021) | 0.103—0.230(0.122) |
| EndoII | ND—0.161 (0.046) | ND—0.057(0.021) | 0.026—0.161(0.080) |
| Endosulfate | 0.030—0.500 (0.175) | 0.030—0.180(0.086) | 0.200—0.500(0.294) |
| <i>p,p'</i> -DDE | 0.011—0.342 (0.108) | 0.011—0.109(0.041) | 0.115—0.342(0.174) |
| <i>p,p'</i> -DDD | ND—0.121 (0.079) | ND—0.077(0.038) | 0.011—0.121(0.059) |
| <i>o,p'</i> -DDT | 0.049—0.467 (0.212) | 0.049—0.226(0.113) | 0.302—0.467(0.310) |
| <i>p,p'</i> -DDT | ND—0.090 (0.031) | ND—0.039(0.011) | 0.046—0.090(0.050) |
| Σ DDTs ^b | 0.094—0.875 (0.371) | 0.094—0.384(0.162) | 0.532—0.875(0.434) |
| Σ HCHs ^a | 0.100—0.665(0.269) | 0.100—0.453(0.197) | 0.313—0.665 (0.430) |
| Σ OCPs ^c | 1.159—23.625(10.911) | 1.159—11.180(3.295) | 13.250—23.625(18.527) |

ND=Non- detected

Σ HCHs^a= α -HCH + β -HCH + δ -HCH + γ -HCH.

Σ DDTs^b= *p, p'*-DDE + *p, p'*-DDD + *o, p'*-DDT + *p, p'*-DDT.

Σ OCPs^c = Σ HCHs+ Σ DDTs+ Σ other OCPs.

Σ other OCPs = Heptachlor (Hep) + Heptachlor epoxide (Hep-Epo) + TC (Trans-Chlordane) + CC (Cis-Chlordane) +EndoI (α - Endosulfan) +EndoII (β -Endosulfan) +Endosulfate.

The concentration of Chlordane (TC+CC) in OCPs was highest among all the OCPs detected inside and outside the cave with a total concentration of 39.689ng/g and mean value of 9.92 ng /g inside the cave and a total concentration of 4.52 ng/g outside the cave with a mean value of 1.13 ng /g. This is because South china have been using Chlordane to kill termites, so the high concentration of Chlordane observed may be predominantly due to the use of technical Chlordane as a termiticide in this area in previous years . In China, technical chlordane is still being extensively used against termites in buildings, with an estimated amount of over 200 tons year⁻¹ in recent years (Xu et al., 2004).

The next compounds with highest levels of concentration were Heptachlor (Hep) and Heptachlor epoxide (Hep-Epo.) Heptachlor (Hep) was also used and produced in large quantity in China. From 1967 to 1969 the amount of Heptachlor produced was 17 tons, to kill the termites and other insects in the soil. It is shown in Fig 4 that the majors parts of OCPs (HCHs and DDTs) at the cave's innermost sampling locations 9 and 10 did not show the lowest values, but rather slightly greater than the values of sampling locations 7 and 8 at the middle of the cave. This

suggests that there may be a fracture pore near the north mouth that allows some air to come in.

Fig 4 shows that the total concentration of DDTs (Σ DDTs) in soil samples was higher than the total concentration of HCHs (Σ HCHs). This trend is consistent with the previous observations on the contamination of OCPs in soil in China (Zhou et al., 2001). A most likely explanation for the current low concentration of HCHs in soil is due to the difference in the physicochemical and biochemical properties, wherein HCHs have higher water solubility, vapor pressure and biodegradability, and lower lipophilicity and particle affinity compared to the DDTs (Rui et al., 2005). DDTs tend to remain in the particulate phase longer than HCHs. (Nhan et al., 2001).

In comparison with recent research reports, the concentrations of Σ DDTs and Σ HCHs measured in the study area were in the same low range with other pristine areas such as Tibet plateau where the concentration of Σ DDTs ranged from ND to 2.83 ng/g and Σ HCHs ranged from 0.18 to 5.38 ng/g (Fu et al., 2001), and European high altitude mountains that had Σ DDTs and Σ HCHs residual level in the range of 1.7-13 ng/g and 0.08-0.49 ng/g respectively (Grimalt et al., 2004).

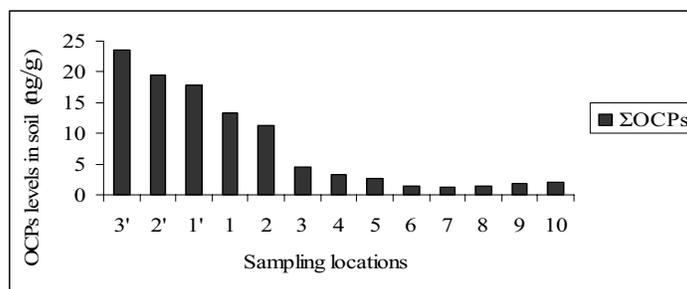

Fig 3: Distribution of ΣOCPs in soil of Dayan cave

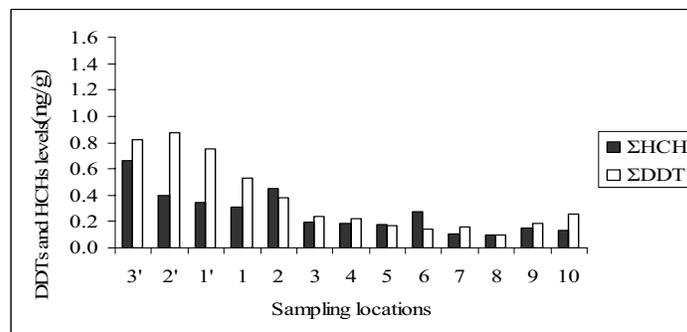

Fig 4: Distribution of ΣHCHs and ΣDDTs in soil of Dayan cave

The average concentration outside the cave and inside the cave of ΣDDTs and ΣHCHs was lower than the average concentration of ΣDDTs and ΣHCHs in Hong Kong soils which was 0.52 ng/g and 6.19ng/g respectively (Zhang et al, 2006), and they were much lower than the average concentrations of ΣDDTs (37.6 ng/g) and ΣHCHs (12.2 ng/g) found in soils of Pearl River Delta Region (Fu et al., 2003). Some other studies reported around China, had higher residual levels of OCPs such as Beijing (Zhu et al, 2005), Tianjin (Tao et al., 2005), Nanjing (An et al., 2005). In Europe, ΣDDTs and ΣHCHs levels were in the range of 4.3-2400 ng/g and 0.36-110 ng/g in Poland soils (Falandysz et al., 2001). In comparison with similar research the levels of OCPs in Guilin were low and the reason is because there are mainly rice farms in the vicinity of Guilin city in which small amounts of OCPs were used with the rotary method of planting rice. The existence of alternating wet and dry conditions was beneficial to the aerobic and anaerobic degradation of OCPs, leading to a reduced amount of soil OCPs.

3.1.1 Distribution and degradation of HCH isomers

It has been widely recognized that HCH is available in two formulations: technical HCH and lindane. Technical HCH contains isomers in the following percentages: α , 55–80%; β , 5–14%; γ , 8–15%; δ , 2–16%; ϵ , 3–5% (Qiu et al., 2004), and Lindane contains > 90% of γ -HCH. The ratio of α -

to γ -HCH has been used to identify the possible HCH source. If the source of HCH comes from fresh input of technical HCH, the ratio of α - to γ - HCH is between 3 and 7 (Yang et al., 2008). However, a lindane source will reduce the ratio to close or <1 (Willet et al., 1998). A higher ratio of α - to γ -HCH than 7 can be explained by long-range transport or re-cycling of technical HCH, because α -HCH has a longer atmospheric lifetime than γ isomer by about 25% (Willet et al., 1998). As shown in Fig 6, the ratios of α -HCH/ γ -HCH in all soil sampling locations were lower than 3. Accordingly, the contamination of HCHs in this region probably came from local use of lindane and also indicated Lindane inputs in the past several years. By analyzing the individual HCH isomers (Fig 5), it was found that β -HCH had the highest level of concentration among all the samples and it accounted from 20.03-79.13 %, especially in sample 3 to 7 where it accounted from 23-79% of the total HCHs detected. The β -HCH was higher because of its persistence in soil. The persistence of β -HCH in soils is mainly due to the higher K_{ow} ($\log K_{ow} = 3.78$) and lower vapor pressure value (3.6×10^{-7} mmHg, 20°C) (Zhang et al., 2006). These will make β -HCH easier to be absorbed to the soil organic matter and less evaporative loss from soils (Mackay et al., 1997). Furthermore, the spatial arrangement of Chlorine atoms in the molecular structure of β -HCH was supposed to be more resistant to microbial degradation in soils (Middeldorp et al., 1996).

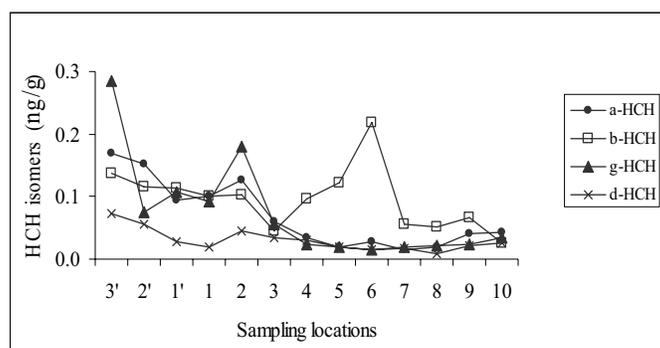

Fig 5: HCH isomers in soil of Dayan cave

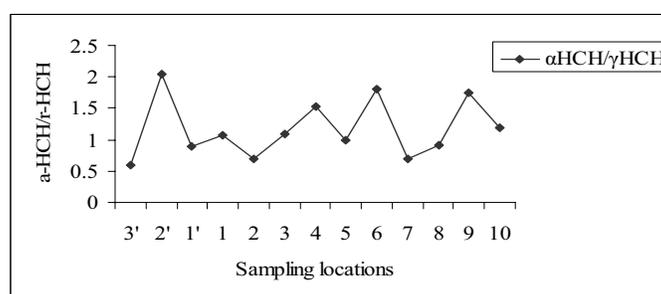

Fig 6: Ratios of α -HCH to γ -HCH in soil of Dayan cave

3.1.2 Distribution and degradation of DDT isomers
Commercial DDT generally contains 75% *p,p'*-DDT, 15% *o,p'*-DDT, 5% *p,p'*-DDE, <0.5% *p,p'*-DDD, <0.5 *o,p'*-DDE and <0.5% of unidentified compounds (WHO, 1979), but in Dicofol, the concentration of *o,p'*-DDT is more than *p,p'*-DDT (Qiu et al., 2005). DDTs isomers have a long persistence in the environment and their levels of concentrations in this study are shown in Fig.7. DDT can be biodegraded under aerobic conditions to DDE and under anaerobic conditions to DDD (Bossi et al., 1992). The ratio of DDD/DDE greater than 1 indicates that the soil was dominated by DDD, the product of anaerobic degradation of DDT, and the ratio lesser than 1 indicates that the soil was dominated by DDE, the product of aerobic degradation of DDT (Zhou et al., 2006). DDE and DDD Changes in the ratio of DDE and DDD to Σ DDTs has been regarded as an indication of either no or decreasing inputs to the environment. The ratio of (DDE+DDD)/ Σ DDTs

greater than 0.5 can be thought to be subjected to a long term weathering (Dong et al, 2002) and More *o, p'*-DDT than *p, p'*-DDT in the environment can demonstrate the Dicofol type DDT usage (Qiu et al., 2004).

The ratios of (DDE+DDD)/ Σ DDTs are shown in Fig.9. The ratios were in the range of 0.26-0.61 with most values being less than 0.5 (mean value is 0.4) and in Fig.7 it is shown that the concentration of *o,p'*-DDT was more than the concentration of *p,p'*-DDT as in Dicofol, this suggests that there was fresh input of Dicofol in the study area. Also, most values of DDD/DDE ratios as shown in Fig. 8 were greater than 1 inside the cave and ranged from 0.092 to 7 with an average value of 2.31, and the ratios of DDD/DDE outside the cave ranged from 0.052 to 0.53 with an average value of 0.35.

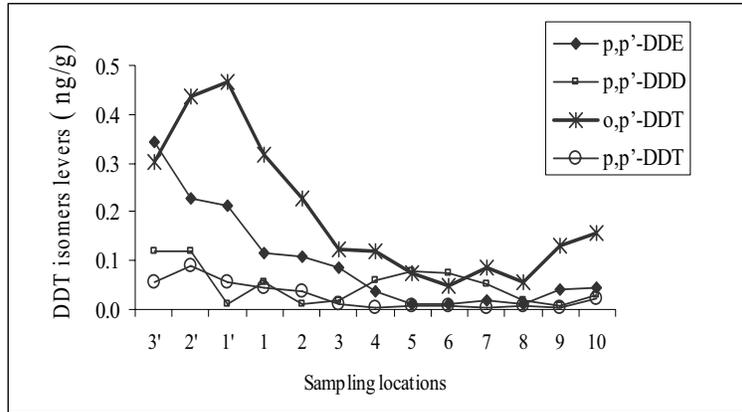

Fig 7: Distribution of DDT isomers in soil of Dayan Cave

The results obtained clearly indicated that DDT in soil inside and outside of the Dayan cave may be derived from Dicofol and DDT was retained under anaerobic conditions inside the cave and under aerobic condition outside the cave.

The use of Dicofol in China is mainly in the southern and eastern provinces, mostly on litchi, longan, citrus crops and cotton (Yang et al., 2008).

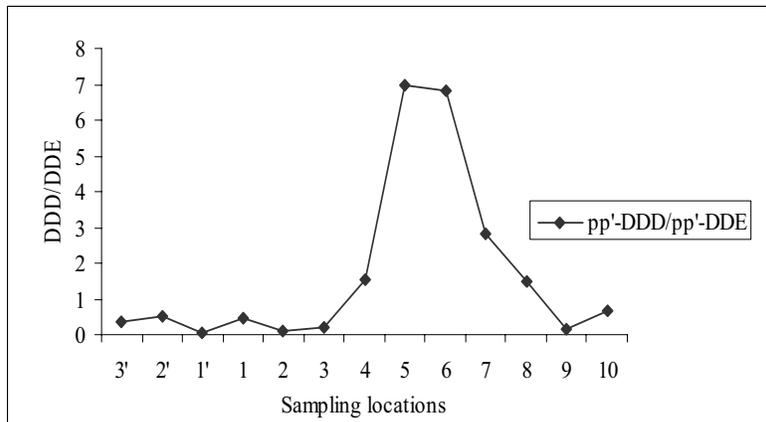

Fig 8: Ratios of DDD/DDE in soil of Dayan Cave

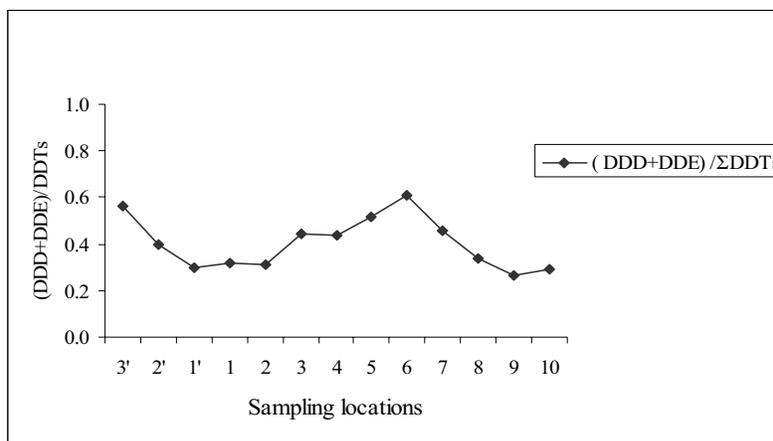

Fig 9: Ratios of (DDD + DDE)/ ΣDDTs in soil of Dayan cave

4. CONCLUSION

The use of HCHs and DDTs in China has been banned for 20 years and this sanction resulted in a tremendous decrease of OCPs concentrations in soils of Dayan cave. The residual levels of OCPs in soils outside Dayan cave were less than corresponding national values and among all the OCPs detected the concentration of chlordane and heptachlor were highest because they have been used in the study area.

ΣDDTs and ΣHCHs in soil inside the cave were low in comparison with worldwide background mountains and polar regions. As conclusion the pollution of OCPs in the soils inside and outside Dayan cave was light.

The analysis of isomers of DDTs and HCHs showed that there is fresh use of Dicofol and Lindane respectively in the study area. DDT degradation outside the cave was aerobic while inside the cave the degradation of DDT was anaerobic.

ACKNOWLEDGEMENT

The authors wish to pay tribute to the referenced authors. This study discusses their work, but the views expressed are those of authors and do not represent those of the referenced authors.

Corresponding to:

Annette Sylvie Muhayimana
Department of Environmental Engineering
Faculty of Environmental Studies,
Key Laboratory of Bio and Environmental
Geology of Ministry of Education,
China University of Geosciences, Wuhan, Hubei
430074, China

E-mail: teteli2001@yahoo.com

Qi Shihua

Department of Environmental Engineering
Faculty of Environmental Studies,
Key Laboratory of Bio and Environmental
Geology of Ministry of Education,
China University of Geosciences, Wuhan, Hubei
430074, China

E-mail: shihuaqi@cug.edu.cn

REFERENCES

1. An, Q., Dong, Y.H., Wang, H., 2005. Residues and distribution character of organochlorine pesticides in soils in Nanjing area. *Acta Scientiae Circumstantiae*, 25, 470-474.
2. Bossi, R., Laesen, B., Premazze, G., 1992. Polychlorinated biphenyl congeners and other chlorinated hydrocarbons in bottom sediment cores of lake Garden (Italy). *Sci. Total Environ.*, 121, 77-93.
3. Colborn, T., Dumanoski, D., Myers, J.P., 1996. *Our Stolen Future*. Dutton, New York, USA.
4. Doong, R.A., Peng, C.K., Sun, Y.C., Liao, P.L., 2002. Composition and distribution of organochlorine pesticide residues in surface sediments from the Wu-Shi River estuary, Taiwan. *Mar. Pollut. Bull.*, 45, 246-253.
5. Falandysz, J., Brudnowska, B., Kawano M., 2001. Polychlorinated Bi-phenyls and Organochlorine Pesticides in Soils from the Southern Part of Poland. *Arch. Environ. Contam. Toxicol.*, 40:173-178
6. Fu, J.M., Mai, B.X., Sheng, G.Y., Zhang, G., Wang, X.M., Peng, P.A., Xiao, X.M., Ran, R., Cheng, F.Z., Peng, C.Z., Wang, Z.S., Tang, U.W., 2003. Persistent organic pollutants in environment of the Pearl River

- Delta, China: an overview. *Chemosphere*, 52, 1411-1422.
7. Fu, S., Chu, S.G., Xu, X.B., 2001. Organochlorine pesticide residue in soils from Tibet, China. *Bull. Environ. Contam. Toxicol.*, 66, 171-177
 8. Grimalt, J.O., Drooge, B.L., Ribes, A., Vilanova, R.M., Fernandez, P., Appleby, P., 2004. Persistent organochlorine compounds in soils and sediments of European high altitude mountain lakes. *Chemosphere*, 54 (10): 1549
 9. Harris, M.L., Wilson, L.K., Elliott, J.E., Bishop, C.A., Tomlin, A.D., Henning, K.V., 2000. Transfer of DDT and metabolites from fruit orchard soils to American Robins (*Turdus migratorius*) twenty years after agricultural use of DDT in Canada. *Arch. Environ. Contam. Toxicol.*, 39, 205-220.
 10. Mackay, D., Shiu, W.Y., Ma, K.C., 1997. *Illustrated Handbook of Physical-Chemical properties of Environmental Fate of Organic Chemicals*, vol.V. Lewis Publishers, Boca Raton, FL.
 11. Meijer, S.N., Halsall, C.J., Harner, T., Peters, A.J., Ockenden, W.A., Johnston, A.E., Jones, K.C., 2001. Organochlorine pesticides residues in archived UK soil. *Environ. Sci. Technol.*, 35, 1989-1995.
 12. Middeldorp, P.J.M., Jaspers, M., Zehnder, A.J.B., Schraa, G., 1996. Biotransformation of α -, β -, γ -, and δ - hexachlorocyclohexane under methanogenic conditions. *Environ. Sci. Technol.*, 30, 2345-2349.
 13. Negoita, T.G., Covaci, A., Gheorghe, A., Schepens, P., 2003. Distribution of polychlorinated biphenyls (PCBs) and organochlorine pesticides in soils from the East Antarctic coast. *Journal of Environmental Monitoring*, 5 (2):281-286.
 14. Nhan, D.D., Carvalho, F.P., Am N.M., Tuan, N.Q., Yen, N.T.H., Villeneuve, J.P., 2001. Chlorinated pesticides and PCBs in sediments and molluscs from fresh water canals in the Hanoi region. *Environ. Pollut.*, 112, 311-20.
 15. Qiu, X.H., Zhu, T., Li, J., Pan, H.S., Li, Q.L., Miao, G.F., Gong, J.C., 2004. Organochlorine pesticides in the air around the Taihu Lake, China. *Environ. Sci. Technol.*, 38, 1368-1374.
 16. Qiu, X.H., Zhu, T., Yao, B., Hu, S.W., 2005. Contribution of Dicofol to current DDT pollution in China. *Environ. Sci. Technol.*, 39, 4385-4390.
 17. Rui, Q.Y., Gui, B.J., Qun, F.Z., Chun, G.Y., Jian, J.B.S., 2005. Occurrence and distribution of Organochlorine pesticides in Sediments collected from East China Sea. *Environmental international*, 31, 799-804.
 18. Shivaramaiah, H.M., Odeh, I.O.A., Kennedy, I.R., Skerritt, J.H., 2002. Mapping the distribution of DDT residues as DDE in the soils of the irrigated regions of Northern New South Wales, Australia using ELISA and GIS. *J. Agric. Food Chem.*, 50, 5360-5367
 19. Tanabe, S., 1991. Fate of toxic-chemicals in the tropics. *Marine Pollution Bulletin*, 22, 259-260.
 20. Tao, S., Xu, F.L., Wang, J., Liu, W.X., Gong, Z.M., Fang, J.Y., Zhu, L.Z., Y.M. Luo, Y.M., 2005. Organochlorine pesticides in agriculture soil and vegetables from Tianjin, China. *Environ. Sci. Technol.*, 39, 2494-2499.
 21. Willett, K.L., Ulrich, E.M., Hites, S.A., 1998. Differential toxicity and environmental fates of Hexachlorocyclohexane isomers. *Environ. Sci. Technol.*, 32(15): 2197-207
 22. World Health Organization (WHO), 1979. DDTs and its derivations. WHO, New York.
 23. Xu, D., Deng, L., Chai, Z., Mao, X., 2004. Organohalogenated compounds in pine needles from Beijing city, China. *Chemosphere*, 57, 1343-1353.
 24. Yang, Y., Li, D., Mu, D., 2008. Levels seasonal Variations and sources of OCPs in ambient air of Guangzhou, China. *Atmospheric Environment*, 42, 677-687.
 25. Zhang, H.B., Luo, Y.M., Zhao, Q.Z., Wong, M.H., Zhang, G.L., 2006. Residues of Organochlorine pesticides in Hong Kong soils. *Chemosphere*, 63, 633-641.
 26. Zhang, H., Lu, Y., Dawson, R.W., Shi, Y., Wang, T., 2005. Classification and ordination of DDT and HCH in soil samples from the Guanting Reservoir, China. *Chemosphere*, 60, 762-769.
 27. Zhao, L., Ma, Y., 2001. Effect of organic residues on soil environment. *Soils*, 33, 309-311.
 28. Zhou, J.L., Maskaoui, K., Qiu, Y.W., Hong, H.S., Wang, Z.D., 2001. Polychlorinated biphenyl congeners and Organochlorine insecticides in the water column and sediments of Daya Bay, China. *Environ. Pollut.*, 113: 373-84
 29. Zhou, R., Zhu, L., Yang, K., Chen, Y., 2006. Distribution of OCP's in surface water and Sediments from Qiantang River, East China. Department of Environmental Science, Zhejiang University.
 30. Zhu, Y., Liu, H., L., Xi, Z., Cheng, H., Xu, X., 2005. Organochlorine pesticides (DDTs and HCHs) in soils from outskirts of Beijing, China. *Chemosphere*, 60, 700-778.

An Incidence of Substratum Discolouration in a Tropical West African Lagoon.

Onyema, I.C. and Nwankwo, D.I.

Department of Marine Sciences, University of Lagos, Nigeria.

iconyema@gmail.com

ABSTRACT: A greenish discolouration of the lagoon floor at the Bayeku area of the Lagos lagoon was observed in January 2006. We report here an investigation of the area between December, 2005 and February, 2006 as part of a larger study. A total of 19 species from 13 genera were reported. *Oscillatoria tenuis* (95,800 trichomes per ml) was implicated as the causative organism for the substratum discolouration. Increased insolation, especially reaching the lagoon floor, low salinity, absence of flood conditions, suitable sediment type (fine – medium sand) and high nutrient ($\text{PO}_4 - \text{P} > 0.24 \text{ mg/L}$; $\text{NO}_3 - \text{N} > 4.40 \text{ mg/L}$) levels possibly encouraged the algal proliferation and subsequent substratum discoloration. It is suggested that improving water quality indices and salinity after January caused the disappearance of the discolouration on the substratum. [Journal of American Science 2009: 5(1), 44-48] (ISSN: 1545-1003)

Key words: algae, water quality indices, substratum.

1. INTRODUCTION

Coastal algal blooms respond to nutrient load from anthropogenic sources (Lee, 1999; Onyema, 2007). South-western Nigeria is endowed with an intricate network of rivers, creeks and lagoons, that serve as conduits transferring highly nutrified waters from hinterland to coastal areas. Bloom conditions have been reported in some of these waters (Nwankwo *et al.*, 2003a; Nwankwo *et al.*, 2008). Blooms of *Microcystis aureginosa*, *M. flos-aquae* and *M. wesenbergii* were reported in the Lagos lagoon (Nwankwo, 1993), Ogun river at Iju (Nwankwo, 1993) causing bluish colouration, anoxia, odour, impacting taste to the water (Nwankwo *et al.*, 2003a) and kuramo lagoon (Nwankwo *et al.*, 2008). Blooms of *Trichodesmium thiebautii* have also been reported off the Lagos coast (Nwankwo, 1993) during thermocline conditions and more recently a bloom of *Bellerochea malleus* that caused brownish discolouration off the Light house beach, Lagos (Nwankwo *et al.*, 2004) was documented. Blooms of *Anabaena flos-aquae*, *A. spiroides* (cyanobacteria), *Cerataulina bergoni*, *Chaetoceros convolutus*, *Coscinodiscus centralis* (diatoms) and *Ceratium furca*, *C. fusus*, *C. tripos* and *Noctiluca scintillans* (dinoflagellates) are known to induce harmful effects in waters of south-western Nigeria (Nwankwo, 1993; Nwankwo *et al.*, 2003a, b, Onyema, 2008). There is at present a report of substratum discolouration in the Lagos lagoon system (Onyema and Nwankwo, 2006) implicating *Beggiatoa alba* and *Oscillatoria* spp as causative species.

Between December, 2005 and February, 2006, a greenish discolouration of the substratum at Bayeku was observed and thoroughly investigated. We report here the composition of the organisms before, during the bloom

period and after the collapse. Water quality indices before, during and after the substratum discolouration were also estimated and investigated. This report is part of a larger study that was already ongoing at the time of the occurrence.

2. MATERIALS AND METHODS

Description of study area:

The Lagos lagoon opens into the sea via the Lagos harbour all through the year. The tidal height is low (<1.5m) and the tidal exchange weak. It is shallow (<2m) and connected to the Epe lagoon to the east. The area investigated was (Fig 1) the Bayeku area of the Lagos lagoon (Latitudes $6^{\circ} 32' \text{N}$ and $6^{\circ} 31' \text{N}$ and Longitudes $3^{\circ} 31' \text{E}$ and $3^{\circ} 32' \text{E}$). A greenish, slimy covering of suspected algae on the lagoon floor was observed for the very first time in this area. Nutrient rich water is known to flow from eutrophic creeks and creeklets systems in the area. Furthermore, poor sewerage systems are the common state of the rural dwellers of the immediate area. Hence direct dumping of domestic wastes is carried out in the closet water body.

Collection of samples

Water samples for determining water quality characteristics were collected at the site before substratum sample collection. The boat was anchored throughout sample collections. Water samples were collected in 1L plastic bottles with screw cap from 0.5m depth from the water surface. This was labeled and transported to the laboratory for chemical analysis.

Substratum samples (top 5cm) were collected within a 5cm² quadrat carefully placed on the greenish material / lagoon floor. A spatula was gently used underwater to scrape the topmost part. After carefully scooping up the greenish scum, it was gently spooned into a plastic bag while still underwater. Duplicate samples

were collected on each occasion. Out of water and in the boat, samples were transferred to 75cl screw capped plastic containers. Samples were fixed with formalin (4% unbuffered) and labeled appropriately on the field before onward transportation to the laboratory. This process was carried out on each sampling occasion.

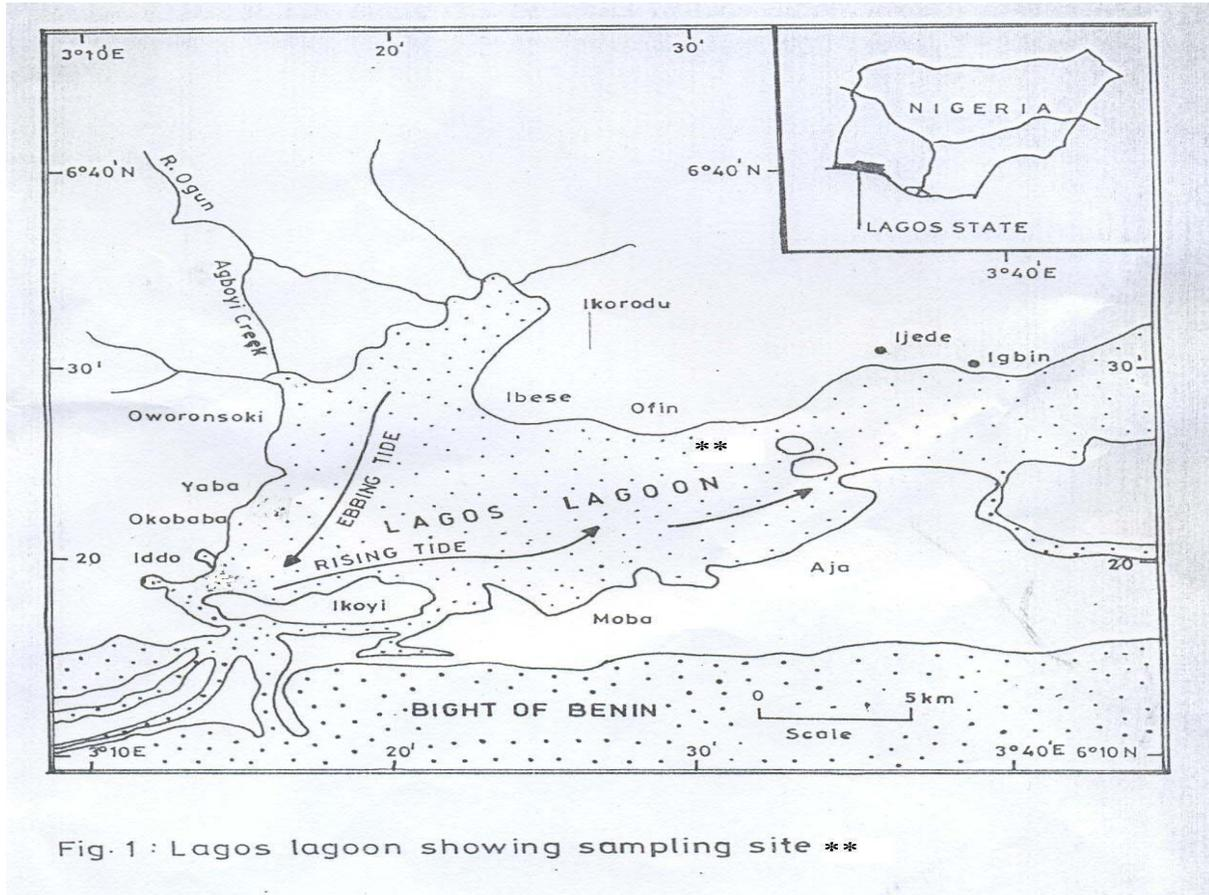

Fig. 1 : Lagos lagoon showing sampling site **

Physico-chemical analysis

Air and surface water temperatures were measured in-situ using a mercury thermometer while water depth was estimated with a calibrated pole. Total dissolved solids was determined by evaporating 100ml aliquot at 105°C and total suspended solids estimated by filtering 100ml of sample through a pre-weighed filter paper, dried to constant weight and reweigh. Conductivity was measured using the HANNA instrument while salinity was determined using the silver-nitrate chromate method. The surface water pH was determined with a Griffin pH meter (Model 80) while dissolved oxygen was measured using a Griffin oxygen meter (Model 40). Biological and chemical oxygen demands were measured using methods described in APHA (1998) for water analysis. Calorimetric methods using a Lovibond Nesslerier were adopted for the direct determination of phosphate-phosphorus and nitrate-

nitrogen values while sulphate levels were measured using the gravimetric method. Calcium and magnesium ions were determined using a 400 single channel, low flame photometer. Concentrations of copper, iron and zinc were determined with an atomic absorption spectrophotometer (A.A.S.) Uni cam 99model.

Biological Analyses

In the laboratory, the drop count microscope analysis method described by Onyema (2007) was used to estimate the substratum algal flora. Microscope analysis was carried out on samples within 48hours of collection. Identification materials were used to assist and confirm identification of species (Smith 1950; Hendey, 1958, 1964; Desikachary, 1959; Wimpenny, 1966; Patrick and Reimer, 1966, 1975; Whitford and Schmacher, 1973;

Vanlandingham, 1982; Nwankwo, 1990, 2004a; Bettrons and Castrejon, 1999; Siver, 2003; Rosowski, 2003).

3. RESULTS

Physico-chemical

Air (31 - 32 °C) and water (30 - 31 °C) temperatures were high through out the sampling period while the sampling depth was averagely 1.31m. The water remained slightly alkaline throughout the study (7.01 – 7.10). The total dissolved solids (20 - 33 mg/L), salinity (2.30 - 20.60 ‰), chloride content (770.0 – 6930 mg/L), conductivity (2335 – 12,500 µS/cm), acidity (3.0 - 8.8 mg/L), alkalinity (28.5 - 100.3 mg/L), total hardness (562.5 - 4687.0 mg/L), sulphate (6.1 – 60 mg/L) and cation content (Calcium 111- 500, Magnesium 35.6- 859 mg/L) increased as the dry season progressed, while there was a corresponding decrease in total suspended solids (1590 – 8260 mg/L), nitrate (2.5 - 4.8 mg/L), biological (5

- 11mg/L) and chemical oxygen demands (10 – 49 mg/L) and heavy metals levels (Iron 0.14 - 0.35, Zinc 0.003 - 0.006mg/L) (Table 1).

With regard to the algae, just one species each was recorded for December 2005 (*Microcystis aureginosa* Kutzing) and January 2006 (*Oscillatoria tenuis* Agardh), However, 17 species were recorded in February (Table 2). Although, total biomass in terms of cell numbers was high in January (95,800 trichomes per ml) it was for a sole species. This organism (*Oscillatoria tenuis* Agardh) is the implicated microalgae responsible for the greenish discolouration of the lagoon floor at Bayeku. Furthermore, February recorded 3 cyanobacteria, 8 centric diatoms and 6 pennate diatoms species. *Actinophycus splendens* Ralfs and *Biddulphia laevis* Ehrenberg were important diatoms and *Oscillatoria limnosa* Agardh for the cyanobacteria in terms of numbers in February.

Table 1
Monthly variation in water quality characteristics
at Bayeku area of the Lagos lagoon (Dec., 2005 – Feb., 2006).

| Physico-chemical parameters | Dec., 2005 | Jan., 2006 | Feb., 2006 |
|---------------------------------|------------|------------|------------|
| Air temperature (°C) | 32 | 31 | 31 |
| Water temperature (°C) | 30 | 31 | 30 |
| Depth (m) | 1.42 | 1.24 | 1.41 |
| Total Suspended Solids (mg/L) | 33 | 27 | 20 |
| Total dissolved Solids (mg/L) | 1590 | 5120 | 8260 |
| Salinity (‰) | 2.30 | 9.20 | 20.60 |
| Chloride (mg/L) | 770.0 | 3086.0 | 6930 |
| Conductivity (µS/cm) | 2335 | 7877 | 12500 |
| pH | 7.05 | 7.01 | 7.10 |
| Acidity (mg/L) | 3.0 | 8.8 | 8.1 |
| Alkalinity (mg/L) | 28.5 | 30.4 | 100.3 |
| Total Hardness (mg/L) | 562.5 | 360.0 | 4687.0 |
| Nitrate- Nitrogen (mg/L) | 4.4 | 4.8 | 2.5 |
| Sulphate (mg/L) | 6.1 | 10.8 | 60 |
| Phosphate- Phosphorus (mg/L) | 0.24 | 0.26 | 0.04 |
| Silica (SiO ₂ mg/L) | 1.9 | 2.6 | 2.1 |
| Dissolved Oxygen (mg/L) | 5.5 | 4.2 | 4.3 |
| Biological Oxygen Demand (mg/L) | 11 | 9 | 5 |
| Chemical Oxygen Demand (mg/L) | 49 | 27 | 10 |
| Calcium (mg/L) | 165 | 111 | 500 |
| Magnesium (mg/L) | 35.6 | 50 | 859 |
| Copper (mg/L) | 0.002 | 0.002 | 0.002 |
| Iron (mg/L) | 0.35 | 0.22 | 0.14 |
| Zinc (mg/L) | 0.005 | 0.006 | 0.003 |

Table 2
 Substratum algal composition (before, during and post bloom) at Bayeku (per ml).

| Algal Taxa | Dec., 2005 | (Bloom) Jan., 2006 | Feb., 2006 |
|---|------------|-----------------------|------------|
| Class – Cyanophyceae | | | |
| Order I – Chroococcales | | | |
| <i>Microcystis aureginosa</i> Kutzing | 170 | - | - |
| Order II – Hormogonales | | | |
| <i>Lyngbya limnetica</i> Lemm | - | - | 5 |
| <i>Oscillatoria curviceps</i> C.A. Agardh | - | - | 10 |
| <i>Oscillatoria limnosa</i> Agardh | - | - | 60 |
| <i>Oscillatoria tenuis</i> Agardh | - | 95,800 | - |
| Class – Bacillariophyta | | | |
| Order I - Centrales | | | |
| <i>Actinophycus splendens</i> (Sch adbolt) Ralfs | - | - | 205 |
| <i>Biddulphia laevis</i> Ehrenberg | - | - | 125 |
| <i>Coscinodiscus centralis</i> Ehrenberg | - | - | 10 |
| <i>Coscinodiscus eccentricus</i> Ehrenberg | - | - | 10 |
| <i>Coscinodiscus radiatus</i> Ehrenberg | - | - | 5 |
| <i>Cyclotella meneghiniana</i> Kutzing | - | - | 15 |
| <i>Melosira moniliformis</i> (O.F. Muller) Agardh | - | - | 10 |
| <i>Melosira nummuloides</i> Agardh | - | - | 35 |
| Order II – Pennales | | | |
| <i>Cymbella affinis</i> Kutzing | - | - | 15 |
| <i>Navicula mutica</i> Kutzing | - | - | 5 |
| <i>Nitzschia palea</i> (Kutzing) Wm Smith | - | - | 5 |
| <i>Pleurosigma angulatum</i> (Quekett) Wm Smith | - | - | 55 |
| <i>Pleurosigma elongatum</i> Wm Smith | - | - | 15 |
| <i>Synedra crystallina</i> Kutzing | - | - | 20 |
| Number of species (S) | 1 | 1 | 17 |
| Species abundance (N) | 170 | 95,800 | 605 |

4. DISCUSSION

The water quality status at the site ranged between low and high brackish water conditions. Low brackish condition (S=2.30‰) was experienced in December while high brackish condition (>9.20‰) reflected the dry months. As the rain ceased, turbidity reduced while transparency increased. Furthermore, insolation increased probably reaching the lagoon floor. This coupled with high nutrient levels ($PO_3^{2-} > 0.24\text{mg/L}$, $NO_3^- > 4.4\text{mg/L}$, $SO_4^{2-} > 6.1\text{mg/L}$), low brackish condition ($<9.2^0/_{00}$) and low depth (<1.42m), favorable sediment type (fine – medium sand) and absence of flood conditions probably encouraged the proliferation of the epipellic algal population in January. According to Valangdiham (1982), *Oscillatoria tenuis*, the causative cyanobacterium, in the substratum discolouration, is a saprobiont which can exist either as plankton or as an attached form. Palmer (1969) reported that *Oscillatoria tenuis* is the second most tolerant *Oscillatoria* species to organically induced stress. It's important to note that both sole species in December and January are known pollution tolerant cyanobacteria forms for the region (Nwankwo, 2004b). Importantly, the highest level of nitrate (4.8 mg/L) recorded for this study was in January at the time of the greenish occurrence. *Oscillatoria* spp are reported in literature to have wide tolerance limits to pH, salts and organically enriched environments (Valangdiham, 1982; Lee, 1999; Nwankwo,

2004b; Onyema, 2008). In Nigeria, Onyema *et al.*, (2003) has reported *Oscillatoria tenuis* in organically polluted parts of Lagos lagoon. Similarly, Chindah and Pudo (1991) have reported *Oscillatoria tenuis* from the Bonny river associated with oil related effluent. According to Valangdiham (1982) *Oscillatoria* species are heavily favoured in organically nutrified waters. The existence of high BOD levels in excess of 9mg/L at this site may be pointer to the probably stressed water quality status. According to Hynes (1960), BOD above 8.0mg/L may indicate severe organic pollution. The disappearance of the bloom in February may be associated with increased salinity ($\geq 20.6^0/_{00}$) and reduced nutrient load ($PO_4 - P = 0.04\text{mg/L}$; $NO_3-N = 2.05\text{mg/L}$). Onyema and Nwankwo (2006) reported a high abundance of epipellic algal forms in the dry months at some organically polluted sites of an estuarine creek in Lagos. This investigation highlights the bane of increasing levels of pollutants from anthropogenic sources in the Lagos lagoon and the role of algal indicators in capturing changes in water quality.

Corresponding author:

Onyema, I.C.

Department of Marine Sciences,
 University of Lagos, Nigeria.

iconyema@gmail.com

REFERENCES

1. American Public Health Association. (1998). *Standard Methods for the Examination of Water and Waste Water*. 20th ed. APHA New York. 1270pp.
2. Bettrons, D.A.S. and Castrejon, E.S. (1999). Structure of benthic diatom assemblages from a mangrove environment in a Mexican subtropical lagoon. *Biotropica*. **31**(1): 48 – 70.
3. Chinda, A.C and Pudo, J. (1991). A preliminary checklist of algae found in plankton of Bonny River in Niger Delta, Nigeria. *Fragm flor. Geobot.***36** (1): 112-126
4. Desikachary, T.V. (1959). *Cyanophyta*. Indian Council of Agric. Research, New Delhi. 686pp.
5. Hendey, N.I. (1958). Marine diatoms from West African Ports. *Journal of Royal Microscopic Society*. **77**: 28-88. Hendey, N.I. (1964). An introductory account of the smaller algae of British coastal waters. Part 5. Bacillariophyceae (diatoms) London. N.M.S.O. 317pp.
6. Hynes, H.B. (1960). The biology of polluted waters. Liverpool University Press, Liverpool, 1-202 pp
7. Lee, R.E. (1999). *Phycology*. Cambridge University Press, New York. 614pp.
8. Nwankwo, D.I. (1993). Cyanobacteria bloom species in coastal waters of South-Western Nigeria. *Archiv Hydrobiologie Supplement*. **90**: 553-542.
9. Nwankwo, D.I. (1990). Contribution to the Diatom flora of Nigeria. Diatoms of Lagos lagoon and the adjacent sea. *Nigerian Journal of Botany*. **3**: 53-70.
10. Nwankwo, D.I. (2004a). *A Practical Guide to the study of algae*. JAS Publishers, Lagos, Nigeria. 84pp.
11. Nwankwo, D.I. (2004b). The Microalgae: Our indispensable allies in aquatic monitoring and biodiversity sustainability. University of Lagos Press. Inaugural lecture seris. 44pp.
12. Nwankwo, D.I., Onyema, I.C. and Adesalu, T.A.(2003a). A survey of harmful algae in coastal waters of south-western Nigeria. *Journal of Nigerian Environmental Society*. **1**(2). 241 – 246.
13. Nwankwo, D.I., Onyema, I.C., Adesalu, T.A., Olabode, R.J., Osiegbu, G.O. and Owoseni, T.I. (2003b). Additions to a Preliminary Checklist of Planktonic Algae in Lagos lagoon, Nigeria. *Journal of Science Technology and Environment*. **3**(1): 8 – 12.
14. Nwankwo, D.I., Onyema, I.C., Labiran, C.O., Otuorumo, O.A.; Onadipe, E.I.; Ebulu, M.O. and Emubaiye, N. (2004). Notes on the observations of brown water discolouration off the light house beach, Lagos, Nigeria. *Discovery and Innovation*. **16** (3). 111 – 116.
15. Nwankwo, D.I., Owoseni, T.I., Usilo, D.A., Obinyan I., Uche, A.C. and Onyema, I.C. (2008). Hydrochemistry and plankton dynamics of Kuramo lagoon. *Life Science Journal*. **5** (3): 50 – 55.
16. Onyema, I.C. (2007). Mudflat microalgae of a tropical bay in Lagos, Nigeria. *Asian Journal of Microbiology, Biotechnology and Environmental Sciences*. **9** (4): 877 – 883.
17. Onyema, I.C. (2008). Phytoplankton biomass and diversity at the Iyagbe lagoon Lagos, Nigeria. University of Lagos, Akoka. Department of Marine Sciences. 266pp
18. Onyema, I.C. and Nwankwo, D.I. (2006). The epipellic assemblage of a polluted estuarine creek in Lagos, Nigeria. *Pollution Research*. **25**(3): 459 - 468.
19. Onyema, I.C., Otudeko, O.G. and Nwankwo, D.I. (2003). The distribution and composition of plankton around a sewage disposal site at Iddo, Nigeria. *Journal of Scientific Research Development*. **7**: 11-24.
20. Smith, G.M. (1950). *The fresh-water algae of the United States*. McGraw-Hill, London.719pp
21. Siver, P.A. (2003). Synurophyte algae. **In: Freshwater Algae of North America**. Ecology and Classification. Wehr, J.D. and Sheath, R.G. (Eds). Academic Press, New York. pp 523 – 558
22. Palmer, C.M. (1969). A composite rating of algae tolerating organic pollution. *Journal of Phycology*. **5**(1): 78 – 82.
23. Patrick, R. and Reimer, C.W. (1966). The diatoms of the United States exclusive of Alaska and Hawaii (Vol. 1). *Monogr. Acad. Nat. Sci.* Philadelphia. 686pp.
24. Patrick, R. and Reimer, C.W. (1975). The diatoms of the United States exclusive of Alaska and Hawaii (Vol. 2, part 1). *Monogr. Acad. Nat. Sci.* Philadelphia. 213pp.
25. Rosowski, J.R. (2003). Photosynthetic Euglenoids. **In: Freshwater Algae of North America**. Ecology and Classification, Wehr, J.D. and Sheath, R.G. (Eds). Academic Press, New York. pp 383 – 422.
26. Round, F.E. (1953). An investigation of two benthic algal communities in Malham Tarn, Yorkshire. *J. Ecol.* **41**: 174-187.
27. Vanlandingham, S.L. (1982). Guide to the identification and environmental requirements and pollution tolerance of freshwater blue-green algae (cyanophyta). U.S. Environmental Protection Agency, EPA – 60.
28. Whitford, L.A. and Schmacher, G.H. (1973). *A manual of freshwater algae*. Sparks press Raeigh. 324pp.
29. Wimpenny, R.S. (1966). *The plankton of the sea*. Faber and Faber Limited, London. 426pp.

Research Article

The Influences of Extremely Low Frequency AC Magnetic Fields At 60Hz on Mung Beans Growth

Pai-Tsun Tien and Show-Ran Wang

Department of Electronic Engineering, National Taiwan University of Science and Technology, Taipei
106, Taiwan, ROC
E-mail: tyanbt@cht.com.tw

ABSTRACT: There are many reports about the biological effects of extremely low frequency magnetic fields (ELF MFs), but few of them investigate how different intensity MFs act upon the growth of living organisms. This study aims to assess the influences of the different intensity of ELF MFs on the early growth of living organisms using mung beans as test materials. We used 60Hz 110Vrms AC electric power as the source and made a toroidal magnetic coil by self for this experiment. The ELF MF is induced using a magnetic circuit with a toroidal magnetic coil and a 60W lamp in series, which is driven by 60Hz 110V AC electric power, the maximum intensity of ELF MF is 950mG. To utilize the magnetic field intensity decay when distance increase, to choose the three kinds different magnetic field intensity (such as 875mG, 155mG and 1.8mG rms value). We used three groups of mung beans (each group is 50 beans) were exposed to the three kinds different magnetic field intensity separately, and observed the lengths of stems and leaves of mung beans after five days growth. The results indicate that the magnetic field intensity is 875mG and 155mG have an enhancing effect on the early growth of mung beans. [Journal of American Science 2009: 5(1), 49-54] (ISSN: 1545-1003)

Key words: ELF MF; biological effect, AC electric power, mung bean

1. INTRODUCTION

Because popularization of electricity and modernization of life, to place in the electric power line generally and use home electrical appliances frequently on the human inhabitancy space, there are ELF MFs produced also exists around the living space. We used a magnetic meter (TES-1390 ELF Magnetic Field Meter, Bandwidth: 50~300Hz, TES Electrical Electronic Corp. made in Taiwan) to measure the root mean square value of ELF MF intensity of home electrical appliances such as hairdryer, desk lamp, razor, etc. We can get magnetic field intensity greater than 100mG (rms value), when to measure home electrical appliances closely (5cm

to 10cm away). Because most countries adopt the reference levels which were announced by ICNIRP in 1998 for general public exposure to time-varying electric and magnetic fields as the standard. The formula of reference level for general public is $50/f$ (f is the frequency, unit: KHz), the reference level is 833mG when f is 60Hz. For understanding the biological effect of different kinds magnetic field intensity, we made a toroidal magnetic coil by self, the coil produced the maximum ELF MF intensity is 950mG. To utilize the magnetic field intensity decay when distance increase, to choose the three kinds different magnetic field intensity (such as 875mG, 155mG and 1.8mG rms value). We exposed

test materials (mung beans) in the three kinds different magnetic field intensity, and observed different magnetic field intensities act upon the early growth of test materials.

2. MATERIALS AND METHODS

2.1 Plant material

Mung beans were used as the test subject in this study. We selected 150 mung beans of almost the same weight (0.09 g) and similar appearance, so that the sample error can be greatly reduced, and divided into three groups of 50 mung beans. Two groups of them are grown in a magnetic field (exposed group 1 under higher magnetic intensity and exposed group 2 under lower magnetic field intensity), and the other group is placed in an ambient weak magnetic field (control group). We used a rectangular culture plate (dimension is 47×27× 3.5cm) which was spread the fine sand of depth 3cm to grow three groups of mung beans together. The environmental parameters of

three groups that were maintained in the test room were almost the same, and the light was supplied by white fluorescent lamps .The close environmental parameters of three groups can be achieved so that the growth difference between them only comes from the magnetic field variable. The environmental parameters such as temperature is 28±2°C, humidity is 60±6% ,illumination is 1120±50LUX(day) and 563LUX(night).

2.2 Exposure System

The purpose of this study is mainly to assess the influence on the early growth of mung beans exposed to the different magnetic field intensities. The equipment needed in this experiment included a 60-Watts incandescent lamp, a toroidal magnetic coil, an oscilloscope/ frequency analyzer, etc. In order to produce the environment of higher magnetic intensity, we made a toroidal magnetic coil with air gap by self is shown in Figure 1.

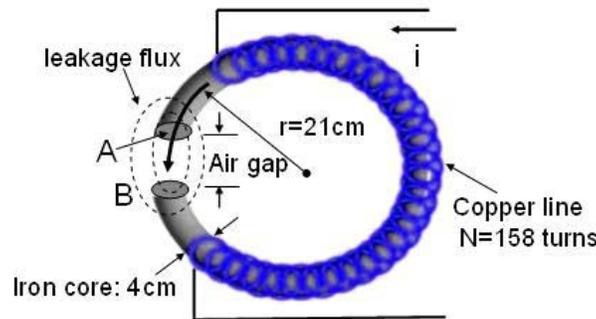

Fig 1: The toroidal magnetic coil with air gap

We entwined Iron wire (cross-section diameter =2mm) to become a toroidal iron core with diameter of 21cm and a 9 cm air gap (cross-section diameter=4cm). The core was wound 158 turns with copper wire (cross-section diameter =2mm) to become a toroidal magnetic coil. The magnetic flux density (B) circulating in the coil and air gap can be theoretically expressed in the following equations:

$$B = \frac{Ni}{RA}, \quad R = \frac{l_c}{\mu A} + \frac{l_g}{\mu_0 A}$$

where R is total magnetic reluctance of the core and air gap, μ and μ_0 are the magnetic permeability of the core and air respectively ($\mu \sim 5000 \mu_0$), A is the cross-section area of the toroidal iron core, N is the

number of turns of coil, i is the current flowing through the coil, l_c and l_g are the core circumference and air gap distance, respectively. The exposure system is shown in Figure 2. We used 60Hz 110Vrms AC electric power as the source and a 60-Watts incandescent lamp as the load, and covered on lamp with an iron bucket to hide the light of lamp, to avoid other interference for mung beans growth.

We measured the highest magnetic field intensity of the air gap of coil is 950mG. The air gap of coil was to be placed the mung beans of exposed

group one. In order to get more experimental data for statistics, we used 50 mung beans of each group which were put on culture plate will take larger area. Because the magnetic field intensity decay when distance increase, we measured the magnetic field intensity of the relative position of each group on culture plate is shown in Figure 2. We got more accurate data were the magnetic field intensity of exposed group one is 875 ± 75 mG, exposed group two is 155 ± 55 mG, control group is 1.8 ± 0.8 mG.

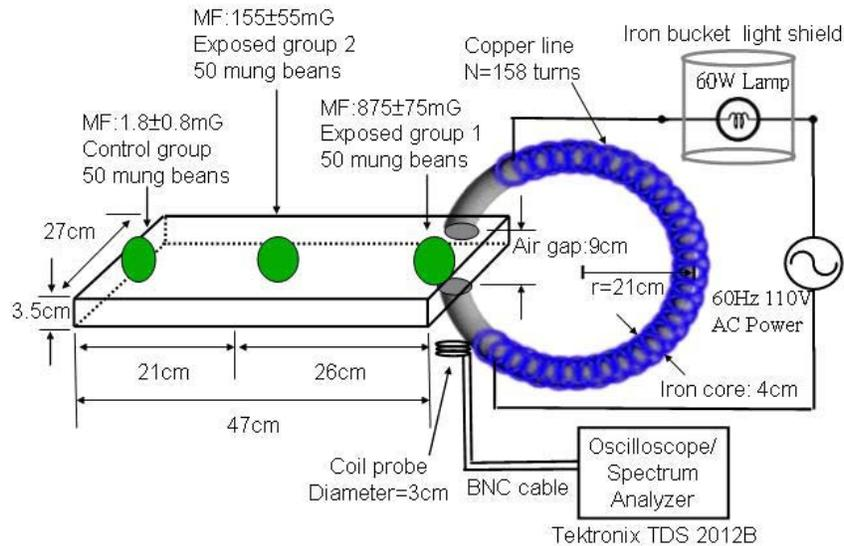

Fig 2: The exposure system of this experiment

The MF source came from the toroidal magnetic coil that was driven by the 60Hz 110V AC electric power. To measure the waveform and spectrum of the ELF MF, we used a little probe coil of diameter 3cm (Misakian, 1993) to induce an electromagnetic force close to the coil. The probe was connected to an oscilloscope/frequency analyzer (Tektronix TDS2012B, Bandwidth:100MHz) to obtain the components of 60Hz 110V AC electric power magnetic field in time and frequency domain are shown in Figure 3 a and b. We found the waveform of 60Hz 110V AC electric power is distortion and the frequency spectrum with harmonics.

2.3 Methods

We prepared three cylindrical containers with diameters of 5cm and poured into 50ml distilled water, then put three groups of mung beans in the cylindrical container, respectively. We moved three cylindrical containers in the positions of rectangular culture plate be shown in Figure 2. After the three groups of mung beans have been imbibing water for 8 hours, so dehydrated beans were simply rehydrated to allow enzyme reactivation, they

were taken out. The three cylindrical containers were removed and three groups of beans were put back in their original positions of culture plate to continue growing, and then were sprayed into appropriate distilled water by a sprinkler every 12 hours. Because three groups of mung beans grew on culture plate together, so the environmental parameters of three groups were almost the same. After mung beans have been growing for 5 days are shown in Figure 4, three groups of mung bean sprouts were taken out, in general mung bean sprout have two leaves, and the stem length and leaves length of each mung bean sprout was measured.

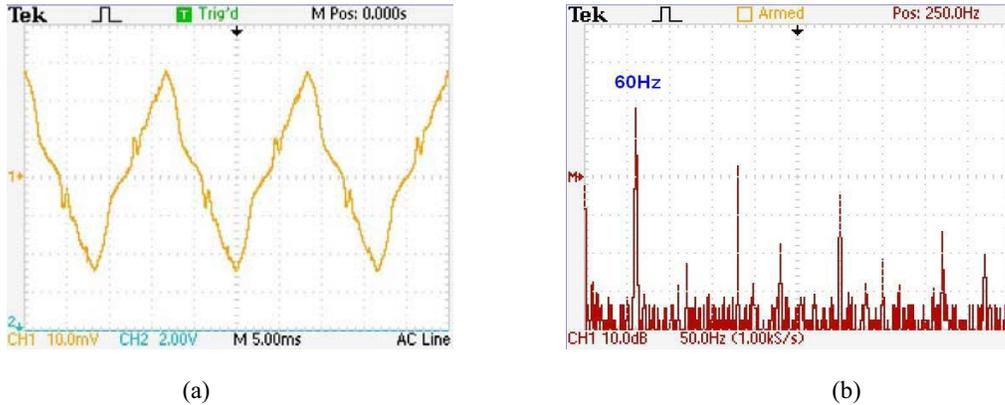

Fig 3: (a) The waveform of 60Hz 100V AC electric power magnetic field is distorted sine wave. (b) The frequency spectrum of 60Hz 100V AC electric power have harmonics, the measured bandwidth of analyzer is 500Hz.

3. RESULT

We observed the growth of two exposed groups was faster than the growth of control group during 5 days. The average stem lengths and average leaf lengths of each group mung bean sprouts were recorded are shown in Figure 5. We analyzed experimental data by statistical method are shown in Table 1. The average stem lengths of mung bean sprouts exposed to 875±75mG and 155±55mG ELF MF were great than those of control mung bean sprouts

($P < 0.01$, one-tailed paired sample t-test). The average leaf lengths of mung bean sprouts exposed to 875±75mG and 155±55mG ELF MF were great than those of control mung bean sprouts ($P < 0.01$, one-tailed paired sample t-test), too. We can find an enhancing effect on the growth of mung bean is exposed under 875±75mG and 155±55mG ELF MF. Otherwise, there is no significant different between the exposed group one and exposed group two mung beans ($P \gg 0.05$, one-tailed paired sample t-test).



Fig 4: The early growth of exposed 1, exposed 2 and control group mung beans after five days

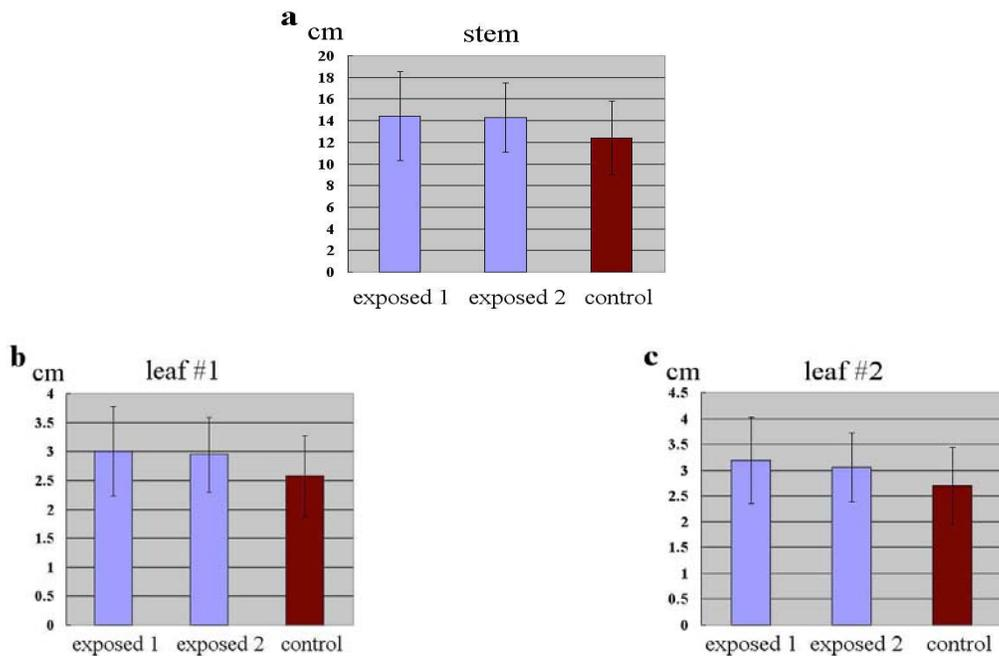

Fig 5 a: The average stem lengths of each group mung beans. b: The average lengths of first leaf of each group mung beans. c: The average lengths of second leaf of each group mung beans.

Table 1
 The statistical analysis of three groups mung beans growth

| statistics | analyze exposed 1 and control group | analyze exposed 2 and control group | analyze exposed 1 and exposed2 group |
|--------------------|-------------------------------------|-------------------------------------|--------------------------------------|
| P value for stem | 0.0054 | 0.0043 | 0.4213 |
| P value for leaf#1 | 0.0025 | 0.0039 | 0.3709 |
| P value for leaf#2 | 0.0017 | 0.0088 | 0.2156 |

4. DISCUSSION

According to the reference levels which were announced by ICNIRP in 1998 is 833mG (f=60Hz) for general public exposure to time-varying electric and magnetic fields, to prevent the influence that may cause to the nervous function of human. However, the experiment results show that the magnetic field intensity is 875±75mG and 155±55mG have an enhancing effect on the growth of mung beans

(Smith,1993;Davies,1993; Soja,2003 ;Huang,2007). So, the growth of plant would be modified when plant exposed ELF MF intensity above 100 mG for a long time. The enhancing influence is abnormal phenomenon for growth of plant, because the motion of Ca^{++} ion on the cells of plant is changed (Lednev,1991;Smith,1993). Therefore, we worry about body health would be influenced when human exposed ELF MF intensity above 100 mG for a long

time. We can get magnetic field intensity greater than 100mG (rms value), when to measure home electrical appliances closely (5cm to 10cm away). To use home electrical appliances closely then we would expose higher magnetic field intensity, maybe influence the health of human body. So should avoid exposing ELF MF intensity above 100 mG for a long time in order to reduce the biological effect of extremely low frequency magnetic fields. For electrical appliances and high-voltage line can induce higher magnetic field, we should keep the appropriate distance to protect the health of human body.

Corresponding to:

Pai-Tsun Tien

Department of Electronic Engineering

National Taiwan University of Science and Technology

43 Keelung Road, Da-an District

Taipei 106, R.O.C.

Telephone: (886) 2-23443021

Fax: (886) 2-23955184

E-mail: tyanbt@cht.com.tw

REFERENCES

1. Lednev VV. Possible mechanism for the influence of weak magnetic fields on biological Systems, *Bioelectromagnetics* 12(1991): 71-75.
2. Liboff AR. The cyclotron resonance hypothesis: Experimental evidence and theoretical constraints. In: Norden B. Ramel C. editors. *Interaction mechanisms of low-level electromagnetic fields in living systems*, New York. Oxford University Press (1992) :130-147.
3. Smith SD, McLeos BR, Liboff AR. effects of CR-tuned 60Hz magnetic fields on sprouting and early growth of *Raphanus sativus*, *Bioelectrochem Bioenerg* 32(1993): 67-76.
4. Davies MS. Effects of 60Hz electromagnetic fields on early growth in three plant species and a replication of previous results, *Bioelectromagnetics* 17(1996): 154-161.
5. Soja G, Kunsch B, Gerzabek M, Reichenauer T, Soja AM, Rippar G., Bolh ar-Nordenkampf HR. Growth and yield of winter wheat (*Triticum aestivum* L.) and corn (*Zea mays* L.) near a high voltage transmission line, *Bioelectromagnetics* 24(2003):91-102
6. Yano A., Ohashi Y., Hirasaki T and Fujiwara K. Effectsof a 60 Hz Magnetic Field on Photosynthetic CO₂ Uptake and Early Growth of Radish Seedlings, *Bioelectromagnetics* 25(2004): 572-581
7. Effects of Weak 162/3Hz Magnetic Fields on Growth Parameters of Young Sunflower and Wheat Seedlings, Fischer G, Tausz M, Kock M, Grill D, *Bioelectromagnetics* 25(2004):638-641
8. ICNIRP Guidelines, Guidelines for limiting exposure to time-varying electric, magnetic, and electromagnetic fields (up to 300 GHz) . (1998):17-18
9. IEEE Standard for Safety Levels with Respect to Human Exposure to Electromagnetic Fields, 0-3 kHz C95.6, IEEE International Committee on Electromagnetic Safety on Non-Ionizing Radiation ,(2002):10-15
10. Misakian M. 1993. ELF electric and magnetic field measurement methods. 1993 IEEE International Symposium on Electromagnetic Compatibility. Dallas, TX, Aug 9-13: Symposium Record. pp. 150-155.
11. Huang HH, Wang SR. 2007. The effects of 60 Hz magnetic fields on plant growth, *Nature and Science* 5(1):60-68.
12. Huang HH, Wang SR. 2008 The Effects of Inverter Magnetic Fields on Early Seed Germination of Mung Beans, *Bioelectromagnetic early view* 2008

Letter

The Inflation Dynamics of the ASEAN-4: A Case Study of the Phillips Curve Relationship

Klarizze Anne M. Puzon

University of the Philippines, Quezon City, Philippines

Email: kmpuzon@gmail.com

ABSTRACT: The conventional Phillips curve argues that there is a trade-off or negative relationship between unemployment and inflation. The aim of this study is to investigate the validity of the Phillips curve for the ASEAN-4 countries: Philippines, Thailand, Indonesia, and Malaysia from 1980 to 2005. Besides unemployment, the relationship of interest rate, exchange rate, and supply shocks to inflation, were also investigated. Using various econometric techniques like Ordinary Least Squares and Instrumental Variables, it was found out that for the ASEAN-4, there seems to be no stable one-to-one trade-off between unemployment and inflation. Variables that could help control inflation were also different for the four countries. For Thailand, the inflation lag, unemployment and oil dummy were significant. As for Indonesia, the interest rate, 1997 East Asian Financial Crisis dummy, and oil dummy were significant in affecting inflation. The OLS regression gave the best linear unbiased estimate for both countries. For the Philippines, serial correlation was detected. Thus, Prais-Winsten method was employed. It was then shown that the unemployment lag, interest rate, and exchange rate lag were significant at the 10% level of significance. [Journal of American Science 2009: 5(1), 55-57](ISSN: 1545-1003)

Key words: Phillips curve; inflation; unemployment; ASEAN

1. INTRODUCTION

The empirical studies on the Phillips curve analyzing the relationship of unemployment rate to the inflation rate are the results of the search for a tool for forecasting inflation and implementing monetary policy. The conventional Phillips curve argues that there is a trade-off or negative relationship between unemployment and inflation (Dornbusch, *et al.* 2005). Economists soon modified the Phillips curve theory to focus on inflation in relation to unemployment. The aim of this paper is to investigate the validity of the Phillips curve for the ASEAN-4 countries: Philippines, Thailand, Indonesia, and Malaysia from 1980 to 2005. Some variables that could affect inflation are also analyzed. Thus, this paper will explore some tools that could aid in the inflation targeting strategies of the ASEAN-4 economies.

2. EMPIRICAL MODEL

I used annual Consumer Price Index, exchange rate (domestic currency per dollar), and money market interest rate data sets supplied by the United Nations Statistical Database (UNSD). For each country, the inflation rate was computed as the percentage change in the Consumer Price Index. That is, inflation rate = $(CPI_t - CPI_{t-1}) / CPI_{t-1} * 100$. All CPI and inflation rates data would have 2000 as the base year ($CPI = 100$). In addition, since the UNSD only have survey data for unemployment, we acquired more reliable unemployment rates from the National Economic Development Authority of the Philippines website. All of the annual data sets covered the period from 1977 to 2005.

For the empirical model, I modified the equations by Gordon (1997), Dua (2006), Stiglitz (1997), Staiger, Stock, and Watson (1997), and Smith (2000). In the formulation of a simple augmented Phillips curve, I also utilized Wan's (2001) linear model involving lagged inflation and cyclical unemployment as explanatory variables.

For Equation 1, I use the augmented version of Stiglitz's model to capture inflationary expectations by including the lagged inflation rate as a measure of the expected inflation rate. In addition, I include an unemployment lag to determine if such would provide a better fit. I also have additional explanatory

variables: interest rate, lagged exchange rate, 1997 East Asian financial crisis binary dummy, and oil shock dummy variable for oil price fluctuations.

$$\pi_t = \beta_0 + \beta_1 \text{unemp}_t + \beta_2 \pi_{t-1} + \beta_3 \text{unemp}_{t-1} + \beta_4 \text{intrate}_t + \beta_5 \text{xr}_{t-1} + \delta_0 97 + \delta_1 \text{oil} + v_t \quad (1)$$

The following are the hypotheses for the signs of the explanatory variables:

- Unemployment, unemp, and unemployment lag, unemp_{t-1}, as stated by the Phillips curve, is negatively related to inflation. That is, if the demand for labor increases due to an expansionary monetary expansion, the unemployment rate would fall causing wages/ prices to rise. Thus, creating a trade-off between inflation and unemployment.
- The inflation lag, π_{t-1} , the assumed expected inflation, is positively related to inflation. I assume this using the adaptive expectations theory.
- The interest rate, intrate, is positively correlated to inflation. Increasing interest rates results to higher costs for businesses, which causes prices to rise.
- Due to policy lags, the current exchange rate may be endogenous. Thus, I assume that the exchange rate lag is exogenous and use it in the model. The exchange rate I use is in the form: domestic currency per dollar. I use xr_1 to account for trade prices. I hypothesize that an increase in xr_1 , a depreciation of the local currency, would increase inflation because of a higher import prices.
- Binary dummies, 97 and oil, were added to account for price shocks brought by the 1997 financial crisis and oil crises. Such control variables are expected to have a positive sign because they serve as supply shocks. To account for East Asian financial crisis, the years 1997 and 1998 have their 97 dummy equal to one. Meanwhile, the oil dummy for 1980, 1990, and 2005 is equal to unity since oil price fluctuations occurred during those years.

For Equation 2, I use first differencing. This model will only be used if the equation experiences unit root problems. Such unit root behavior was tested using the Phillips-Perron test.

$$\Delta\pi_t = \alpha_0 + \Delta\beta_1\text{unemp}_t + \Delta\beta_2\pi_{t-1} + \Delta\beta_3\text{unemp}_{t-1} + \Delta\beta_4\text{intrate}_t + \Delta\beta_5\text{xr}_{t-1} + \delta_0\text{97} + \delta_0\text{oil} + \upsilon_t \quad (2)$$

To have more efficient estimates, I tested Equations 1 or 2 for heteroskedasticity and serial correlation. If either problem exists, corrections are employed to ensure consistent estimates. As will be discussed later, I also used Instrumental Variable method for Malaysia. More specifically, since unit root behavior occurs in the inflation variable, I used an instrument, the inflation lag of Singapore, for the inflation lag of Malaysia.

3. Discussion of Regression Results

Using t-test, with an $H_0: B_j=0$, and a two-sided alternative of $H_1: B_j \neq 0$, the results for Equation 1 can be summarized as follows:

Table 1. Fully-corrected regression results for Equation 1

Dependent variable: Inflation
 Significance level: 10%

| Explanatory Variable | Indonesia | Malaysia | Thailand | Philippines |
|----------------------|-------------------------|-------------------------|-------------------------|-------------------------|
| Infla_1 | -.0488733 (.1096472) | .3483649 (.2066877) | .3773198 (.1637375) | -.0074889 (.1133733) |
| Unemp | 0.2920096 (.7119024) | -.4904054 (.5649236) | -.9443959 (.4813811) | 1.164838 (1.157631) |
| Unemp_1 | .0188285 (.8245843) | .3516186 (.5329042) | -.389395 (.5979983) | -2.008291 (.7032352) |
| Mmintrate | 1.200941 (.1402781) | -.060483 (.1525026) | -3.699473 (.3366451) | 2.594078 (.2925591) |
| Xr_1 | .0001955 (.0008092) | -1.265882 (1.38491) | -.1813196 (.1655893) | .8965375 (.3458095) |
| D97 | -14.92133 (5.921631) | 1.656048 (1.073852) | 4.670027 (2.812547) | -3.558471 (3.915062) |
| Doil | 4.907661 (2.690442) | 1.596374 (1.078417) | 5.304789 (1.658721) | 4.543862 (4.269187) |
| Constant | .5815264 (.9750957) | .07467 (.830654) | -.9713239 (.566889) | -.2621564 (.9492679) |
| R ² | 0.8855 | 0.4730 | 0.6918 | 0.8244 |
| Adj R ² | 0.8409 | 0.2680 | 0.5720 | 0.7561 |
| n | 26 | 26 | 26 | 26 |

For Thailand and Indonesia, the OLS regression gave the best linear unbiased estimate (BLUE). For both countries, the error terms have constant variance and have no autoregressive conditional heteroskedasticity (ARCH). There were also no random walk and serial correlation problems. For Thailand, using the adjusted R² value, 57.20% of the inflation variation was explained by the model. This is an improvement compared to Equation 1's adjusted R² value of 23.44%. Moreover, the inflation lag, current unemployment rate, and oil dummy were significant at the 10% level. The significance of the inflation lag is consistent to the findings of Dua (2006). This may signal that inflation is inertial (Smith, 2000). For Thailand, past inflation influences people's expectations on future inflation. Meanwhile, it was also estimated that a one percentage increase in unemployment, decreases inflation by .94439 percentage points. Such value is very near to one. Thus, I could say that the Phillips curve is present in Thailand using 1980-2005 data. Unemployment and inflation have a trade-off. This finding is similar to that found by Bhanthumnavin (2002). Oil price shocks also influenced Thai inflation values immensely. It was implied that, controlling for all other variables, when there is an oil price shock, predicted inflation is about 5.30 points higher than for a year without an oil price shock (i.e. inflation= doil + constant). That is, when there are oil price fluctuations, inflation increases by about 5.30 + (-.917)= 4.329 percentage points. From these, I could see that as the price of energy rises, the inflation rate will increase as production

becomes more expensive. For Indonesia, the significant variables at the 10% significance level were the interest rate, oil and 1997 financial crisis dummies. The dummy for the 1997 East Asian financial crisis, surprisingly, depresses predicted inflation by about 14.92 percentage points. More specifically, ceteris paribus, during the 1997 East Asian financial crisis, inflation decreases by approximately .581- 14.92= |-14.339| percentage points. Such result, most probably, was due to lower productivity growth and aggregate demand in the economy. This finding was similar to that of Vong (2001) in his study of Macau's Phillips curve. Meanwhile, the oil dummy indicated that, in the presence of oil price shocks, ceteris paribus, predicted inflation for Indonesia, is 4.9076 percentage points higher than usual. That is, when there are oil price shocks, inflation increases by .581 + 4.9076= 5.4886 percentage points. In addition to these, it was seen that unemployment and its lag were not statistically significant. The unemployment variables also had positive signs which could indicate that there maybe no trade-off between inflation and unemployment. Being a developing country, it seems to be that Indonesia suffers from both persistent high inflation and high unemployment rates.

For the Philippines, using OLS, it was found out that the unemployment lag, interest rate, and exchange rate lag were significant at the 10% level. For a one percentage point increase in the unemployment lag, inflation decreases by 2.0367 percentage points. Such supports the trade-off between unemployment and inflation as indicated by the Phillips curve. That is, if the demand for labor increased due to an expansionary monetary policy, the unemployment rate would fall. Then, wages and consumer prices will tend to rise. Moreover, the significance of the unemployment lag could indicate that fiscal policies relating to inflation might not have an immediate effect. There could be policy lags. Meanwhile, a percentage point increase in interest rates increases inflation by 2.613 percentage points. In addition, when the exchange rate lag increases by one percentage point, inflation increases by 0.8893 percentage points. This supports our hypothesis that depreciation in the domestic currency makes local goods more competitive. Such increases aggregate supply and results to an increase in the price level. However, even though the Philippines' OLS model gave significant results, it is not BLUE. Using Durbin's alternative test for autocorrelation, with a p-value of 0.0167, at the 10% significance level, there was evidence that the Philippines' Equation 1 regression suffers from serial correlation. Generally, when corrected for serial correlation, I have seen that the standard errors decreased. Although they are characterized by lower coefficients, unemployment lag, interest rate, and exchange rate remain significant. For a one percentage point increase in the unemployment lag, inflation decreases by 2.0082 percentage points. On the other hand, a percentage point increase in interest rates increases inflation by 2.594 percentage points. In addition, a one point percentage increase in the exchange rate lag increases inflation by 0.8965 percentage points.

For Malaysia, the OLS model explains 43.15% of the variation in inflation. Only unemployment was significant at the 10% level. A one percentage point increase in unemployment decreases inflation by 1.543 percentage point. Such finding is still consistent with the OLS estimates of Tang and Lean (2007): that there exists a trade-off between unemployment and inflation in Malaysia. However, while this might support the Phillips curve hypothesis, we should be careful with the interpretation of results. This is because, when tested for unit root behavior using the Phillips-Perron test, with a p-value of 0.1298, it was found out that the past values of inflation were correlated. In addition, the inflation lag might be endogenous. It might be correlated with the

error term. To solve for this problem, I use the inflation lag of Singapore as an instrumental variable for Malaysia's inflation lag. I use Singapore data since I thought that its price levels might be highly correlated with that of Malaysia. Such may be a result of their geographical proximity and trading relations. The simple correlation of Malaysia's inflation lag with Singapore's inflation lag was 0.7162. In addition, when Malaysian inflation lag was regressed with all other exogenous variables and the Singaporean inflation lag, it was found out that Singapore's inflation lag, with a p-value of 0.079, was significant. This supports one of the assumptions for an instrument. The covariance of our instrument, Singapore's inflation lag, and our x_i , Malaysia's inflation lag, is not zero. Meanwhile, I assume that $\text{Cov}(\text{Singapore_inflation_1}, u) = 0$. When I used `Singapore_inflation_1` as an instrument for `infla_1` in our Malaysian OLS model, the inflation lag and unemployment were significant at the 10% level. The inflation lag fulfilled our expected sign. However, again, we could not be sure as to the reliability of these results. Using the Phillip-Perron test, there was an evidence of a highly persistent time series. The past values of inflation are still correlated. Thus, I use Equation 2, the first-differenced model, for our analysis. The regression with Equation 2 showed that there seems to be no significant variables which could affect inflation. Such results might be consistent but not efficient. This is because of the presence of large standard errors caused by either heteroskedasticity or serial correlation. When tested for both stationary and autoregressive conditional heteroskedasticity, the first-differenced model was characterized by homoskedasticity. However, when tested for serial correlation of order 1, AR(1), and higher order correlation using the Breusch-Godfrey LM test for autocorrelation, it was evident that the Equation 2 for Malaysia suffers from serial correlation. With these, we have seen that although differencing could eliminate most of the serial correlation, it has not done so for our model. Most probably, our model suffers from higher order serial correlation. To correct for serial correlation, I use Prais-Winsten estimation. When corrected for serial correlation, the first-differenced equation, Equation 2, had lower standard errors. This shows that the existence of serial correlation produced large standard errors. For the fully-corrected model, it was only the inflation lag, with a p-value of 0.109, which is nearly significant at the 10% level. From the regression results, it can be seen that as the instrumented inflation lag increases by one percentage point, inflation increases by .3483 percentage points. The nearly significant value might have been the result higher order autocorrelation. The model might not have been fully-corrected because I also used Prais-Winsten method—a method which only employs feasible GLS estimation of AR(1). In addition, we should also take note that the FGLS is not unbiased and therefore, is not BLUE. Moreover, although it may be asymptotically more efficient than the OLS estimator in the presence of serial correlation, we cannot fully assume weak dependence because of a small sample size of 26. Another possible reason for our findings is that `Singapore_inflation_1` might not be a completely exogenous instrument for Malaysia's inflation lag. Our IV, Singapore's inflation lag might be correlated with the error term. This could happen because Malaysia and Singapore are closely-linked economies. For example, there is a possibility that the exchange rate between the currencies of the two countries is correlated to our IV. Thus, Singapore's inflation lag might not be the best IV for Malaysia's inflation lag. With this, it is recommended, that in future studies, the exchange rate lag, the interest rate lag, and others be tested as possible instrumental variables.

I will now focus our discussion on the theorized Phillips curve relationship: trade-off between unemployment and inflation. I will analyze the signs of the unemployment rate for the four countries without emphasizing their significance at the 10% level. Using the fully-corrected models, it was found out that for Thailand and Malaysia, there exist a trade-off between unemployment and inflation. The negative coefficients for unemployment are the evidences for this. The trade-off is approximately one-to-one for the two countries. Such relationship supports the Keynesian view on the Phillips curve. That is, at least for the short-run, unemployment and inflation have a negative relationship. In contrast, the unemployment coefficients for Indonesia and the Philippines were positive. The findings for the Philippines are consistent with Dua's findings (2007). The positive relationship between unemployment and inflation is supported by Rational Expectations Theory. There may be no trade-off between unemployment and inflation because markets respond quickly to changes in prices and wages.

4. Conclusions and Recommendations

For the ASEAN-4, significant or not, there seems to be no stable one-to-one trade-off between unemployment and inflation. I also found out that the variables which could help control inflation were different for the four countries. Meanwhile, to have more conclusive results and achieve normality, I suggest obtaining a bigger sample size, e.g. usage of quarterly data. In conducting tests, such would give us higher degrees of freedom. In addition, for serial correlation problems, error terms such CPI minus unit labor cost can be used (Smith, 2000). I also suggest a lag for interest rates. There maybe a possibility that the previous year's monetary policy regarding interest rates might have a significant effect on the inflation rate. In addition, to better explain inflation dynamics, stock prices, energy/ petroleum prices, and other functional forms (e.g. quadratic or logarithmic form) can be utilized in future studies. Furthermore, panel data analysis could be utilized. Lastly, cointegration tests may be employed to explore the feedback dynamics of employment- inflation relationship.

Correspondence to:

Klarizze Puzon
Email: kmpuzon@gmail.com

REFERENCES

- [1] Bhanthumnavin, K. (2002). The Phillips curve in Thailand. St. Antony's College, University of Oxford Working Paper.
- [2] Dornbusch, R., Fisher, S. & Startz, R. (2005). *Macroeconomics, Ninth Edition*. U.S.A.: McGraw-Hill Education.
- [3] Dua, P. (2006). Inflation- Unemployment Trade-off in Asia. United Nation's Project LINK Meeting. University of Delhi.
- [4] Gordon, R. (1997). The Time-Varying NAIRU and Its Implications for Economic Policy. *Journal of Economic Perspectives, American Economic Association*, vol. 11(1), pages 11-32, Winter.
- [5] National Economic and Development Authority, Republic of the Philippines. (2007). <http://www.neda.gov.ph/>.
- [6] Smith, H. (2000). The Phillips Curve in the 1990s. *University Avenue Undergraduate Journal of Economics*, Year 2000 Issue.
- [7] Staiger, Douglas, James Stock, and Mark Watson. (1997). The NAIRU, Unemployment and Monetary Policy. *Journal of Economic Perspectives* (Winter) pp. 33-49.
- [8] Stiglitz, J. (1997). Reflections on the Natural Rate Hypothesis. *Journal of Economic Perspectives*, Winter, Vol. 11(1), 3-10.
- [9] United Nations. United Nations Statistics Division. (2007). <http://unstats.un.org/unsd/default.htm>.
- [10] Vong, T. (2001). The Phillips Curve in Macau and Its Implications for Macroeconomic Policy. *Monetary Authority of Macau Publication*.
- [11] Wan, Y. (2001). A Case of the Phillips Curve in the Formation of a Monetary Union: A Glimpse at High Inflation Countries of the Monetary Union. *University Avenue Undergraduate Journal of Economics*, Year 2001 Issue.

Estimating Soil Loss Using Universal Soil Loss Equation (USLE) for Soil Conservation planning at Medego Watershed, Northern Ethiopia

Gebreyesus Brhane and Kirubel Mekonen

Center for Development Research (ZEF), University of Bonn, Walter-Flex-Str. 3,

D-53113 Bonn, Germany

E-mail: gebre042001@yahoo.com

ABSTRACT: Water erosion is a major part of land degradation that affects the physical and chemical properties of soils and resulting in on-site nutrient loss and off-site sedimentation of water resources in arid and semi-arid areas of Ethiopia. The heavy reliance of some 85 percent of Ethiopia's growing population on an exploitative kind of subsistence agriculture is a major reason behind the current state of land and soil degradation. Tackling on-site effects of soil erosion requires understanding of the rates of soil loss as well as identification of the major controlling factors that enhance or retard these processes. Therefore, the objective of this study was to predict the amount of soil loss in different landforms and land uses using USLE which is modified and adapted to Ethiopian conditions, at Medego watershed, northern Ethiopia. This study was conducted after massive SWC practices have been implemented in the past 15-year in the study watershed. Primary data and secondary data were collected related to the factors that influence soil loss estimated by USLE and for area description. The land surfaces in the watershed is mainly a reflection of past erosion processes as indicated by many researchers. In this study, the lowest soil loss is estimated on flat plains (< 2% slope) about 1.59 tons ha⁻¹ y⁻¹, which is less than the minimum tolerable soil loss (2 tons ha⁻¹ y⁻¹) for the country. However, the highest soil loss is from steep slopes (30-50%) which is 35.43 tons ha⁻¹ y⁻¹, about twice the maximum tolerable soil loss (18 tons ha⁻¹ y⁻¹). The average soil loss rate at watershed level is 9.63 tons ha⁻¹ y⁻¹ about half of the maximum tolerable soil loss. The implication is the contribution of the implemented SWC measures in decreasing the rate of soil erosion is encourageable as compared to the results related to high soil loss estimated in the past studies i.e., before massive SWC implementation. However, the present value indicates still a need for wise SWC planning that decreases the amount of soil loss in the watershed at least below the maximum tolerable soil loss rate of the country. Therefore, to maximize the available resources in targeting the effect of water erosion on soil loss, those landforms and land uses having large rate of erosion should be given first priority during the introduction of intensive and well designed SWC interventions at Medego watershed, northern Ethiopia. [Journal of American Science 2009: 5(1), 58-69] (ISSN: 1545-1003)

Key words: Medego watershed, northern Ethiopia, soil loss, tolerable soil loss.

Abbreviations: SWC- soil and water conservation, USLE-Universal Soil Loss Equation.

1. INTRODUCTION

Growing degradation and loss of soil means that the expanding population in many parts of the world is pushing this resource to its frontier. In its absence, the biospheric environment of humans would collapse with devastating effects on humanity. Judson (1965) was one of the first geologists to assess the world soil erosion. He estimated that the amount of river-borne soil carried into the oceans had increased from 9.9 billion tons a year before the introduction of agriculture, grazing and related activities, to the present rate of 26.5 billion tons a year. Hydrologists estimated that one-fourth of the soil

lost through erosion in a watershed actually makes it to the ocean as sediment (FAO/UNEP, 1978). The remaining three-fourths are deposited on foothill slopes, in reservoirs, in river plains and other low-lying areas or in the river-bed itself, which often causes channel shifts. In an overview of global erosion and sedimentation, Pimental (1995) stated that more than 50% of the world's pastureland and about 80% of agricultural land suffer from significant erosion.

The causes of land degradation are complex and have diverse nature and dimensions, depending on peculiarities of different countries,

influenced as it is by a combination of natural and socio-economic-cultural factors. In Ethiopia, the heavy reliance of some 85 percent of Ethiopia's growing population on an exploitative kind of subsistence agriculture is a major reason behind the current state of land degradation. Moreover, land degradation is a long-term process in which the effect and steady expansion is hardly noticed until it manifests itself with disastrous drought and famine. Most studies indicate that sheet and rill erosion by water and burning of dung and crop residue are the major components of land degradation that affects on-site land productivity (Hurni, 1993; Zeleke et al., 2001).

Water erosion is a major part of land degradation that affects the physical and chemical properties of soils and resulting in on-site nutrient loss and off-site sedimentation of water resources in arid and semi-arid areas like Ethiopia (Boardman, 1998; Lal, 1999; Bartsch et al., 2002; Emrah et al., 2007). The off-site effects of erosion such as reservoir sedimentation and water resources pollution are usually more costly and severe than the on-site effects on land resources (Phillips, 1989). Therefore, proper management of on-site effect of soil erosion could reduce the risks and negative impacts of down stream water resources due to water erosion. Tackling the on-site effects of soil erosion requires an understanding of the rates of erosion processes as well as identification of the major controlling factors that enhance or retard these processes. The knowledge of "what are the factors and where" may help to distinguish the potential causes and the associated reasons behind the respective causes even though this may not be enough to design site-specific management, as the factors playing a major role in erosion may be widely distributed within watersheds (Ferro et al., 1998; Mirco et al., 2003).

Soil erosion by water and its associated effects are recognized to be severe threats to the national economy of Ethiopia (Hurni, 1993; Sutcliffe, 1993, Tamene, 2005). Since more than 85% of the country's population depends on agriculture for living, physical soil and nutrient losses lead to food insecurity. Hurni (1990, 1993) estimates that soil loss due to erosion in Ethiopia amounts to 1493 million tons per year, of which about 42 tons ha⁻¹ y⁻¹ is estimated to have come from cultivated fields. This is far greater than the tolerable soil loss as well as the annual rate of soil formation in the country. According to an estimate

by FAO (1986), some 50% of the highlands of Ethiopia are already 'significantly eroded,' and erosion causes a decline in land productivity at the rate of 2.2% per year. The study also predicted that by the year 2010, erosion could reduce per capita incomes of the highland population by 30%. Hence, soil and water conservation measures have been implemented to alleviate both problems of erosion and drought, which are symptoms of two different extremes of rainfall conditions since the 1980s in the country. However, so far, little or no sufficient documented information has been available on the contribution of the different SWC measures implemented on soil loss reduction since the last 15-years at the study watershed in the semiarid areas of Ethiopia as compared to the tolerable soil loss determined by Hurni (1985) to Ethiopia condition. Such information is vital to take additional measures and soil conservation planning at the watershed and other similar areas in the semiarid areas. Therefore, the purpose of this study was to estimate the amount of soil loss in different landforms and land uses using USLE at Medego watershed, northern Ethiopia.

2. MATERIALS AND METHODS

2.1. Study Area Description

The study was carried out at Medego watershed in the administrative unit of Lalay-maychew district in Tigray region, northern Ethiopia (Figure 1), from August 2007 to July 2008. Its altitude ranges from 2000 to 2720 m above sea level. The study area is bounded by latitudes N14°05.955' and 14°05.937', and longitudes E038°42.352' and 038°42.333'. The total area of the watershed is about 1091.5 ha as delineated using Geographical Positioning System (GPS) during the field study. The study watershed is characterized by different landforms which are ranged from flat plains, undulating plains and rolling land to steep mountains and very steep escarpments. The description of the topography is adopted the slope capability classification made by (Chekun, 2002), and the slope ranges and area coverage of each landform was recorded at field using clinometers and GPS, as it is presented in Table 1. The geological setup of the watershed is originated from volcanic. However, alluvial deposits at flat lands are also found in the watershed. The soil type at the study watershed is quite different along the slope. At steep slopes, coarse earth materials, gravels and boulder are dominated where as at flat

plain, the largest portion of the study area is covered by clay loam soil and the smaller portion laid on clay and sandy soil textures. The main soil types are cambisols on undulating plains and rolling landforms; lithosols on hilly and steep to very steep lands and vertisols are found on the flat plateau plains of the watershed (BoARD, 2007).

The number of households and total population at Medego watershed is 397 and 1537, respectively. The land holding size of most farmers in the study area is less than 1.3 ha. The watershed has uni-modal and erratic rain fall patterns. The rainy season is very short and extends from June to first week of September. The mean annual amount of rain fall ranges from 600 - 700 mm from historical rainfall data. The mean monthly temperature during the growing season ranges from 15 - 20 ° C (BoARD, 2007). According to the BoARD (2007), the farming system of the study watershed is principally crop oriented. Tef cultivation (*Eragrostic tef*) account for the majority of arable lands and followed by wheat (*Triticum vulgare*) crop. Other crops such as faba bean (*Vicia faba*), field pea (*Pisum sativum*), lentil (*Lens culinaris*), chick pea (*Cicer arietinum*), flax (*Linum usitatissimum*), barley (*Hordeum vulgare*) and maize (*Zea mays*) are also important crops in the farming system. Irrigation is also widely practiced at Medego watershed. In spite of the fact that the high crop diversification in the watershed, it observed that there is still a room to improve the crop productivity. Livestock rearing is also an integral part of the farming system, though the number of livestock in the watershed area is reduced from time to time due to animal feed shortage. According to farmers view, cattle are kept mainly for draught power and milking; goat and sheep are kept for live sale; and equines (donkey, mule, horse, camel) for transportation. The study indicated that 83% of the households in the watershed have some livestock. Of these, 75% are cattle (average of 2 cattle per household), 21% are sheep and goats and the rest is covered by poultry and equines.

It was observed that the vegetation in Medego watershed in general is sparse and has been overexploited for long time and at this time consists of shrubs and bushes of little economic value. The available vegetation species in the study area include seraw (*Acacia etbaica*), chea' (*Acacia abyssinica*), acacha (*Acacia decurrense*) and Awhi (*Cordia africana*) on uncultivated land; and momona (*Acacia albida*), tambock (*Croton machostachys*), keyih bahrizaf (*eucalyptus*

comoldulensis) and some 'seraw (*Acacia etbaica*) on cultivated and marginalized areas. Leuceana (*Leuceana leucecephala*), sesbania (*Sesbania sesban*) and some other grasses are commonly found in the gully of the watershed. Farmers' used such vegetation for the purpose of farm implements, house construction and furniture, fuel wood, soil and water conservation measures and fencing (Table 2). But most farmers have no or little awareness on the function of these tree species for soil and water conservation as compared to the other uses. Hence, awareness creation to farmers in the watershed and other areas should be done in order to the farmers give attention on planting and managing tree species from different perspectives including soil and water conservation, soil fertility improvement.

2.2. Methodology

Primary and secondary data were collected at Medego watershed related to the assessment of SWC measures on soil loss at Medego watershed. Primary data were gathered by topographic transect walk, measuring of input data, informal discussion and observation. The secondary data include climate, demographic and other related data were collected from Bureau of Agriculture and Rural Development (BoARD) at the administrative unit. These data were used to estimate soil loss after tremendous activities of SWC measures have been implemented at Medego watershed, northern Ethiopia. The rapid rural appraisal technique of the topographic transect walk method was employed for its effectiveness in the assessment of the natural resource base and topography of the watershed. In order to obtain as much information as possible, the transect walk was applied in two direction, east to west and south to north. In both directions, the transect walk started at the top edge of the watershed and went all the way across to the other end of the watershed. During the transect walk, observations and estimates of vegetation type and density, and impact of the existing soil and water conservation measures were observed. These were followed by recording land-use types, soil color, soil depth, soil drainage condition, slope gradient and length. The transect walk also provided an opportunity for informal discussions with farmers working on their plots.

Annual soil loss in the form of runoff from different land forms and land uses of the watershed was estimated using the Universal Soil Loss Equation (USLE) (Wischmeier and Smith,

1978) and modified and adapted to Ethiopian conditions by Hurni (1985) and Gebreselassie (1996) as follows.

$$A = R * K * L * S * C * P$$

Where; A = estimated soil loss ($t\ ha^{-1}\ yr^{-1}$), R = Rainfall Erosivity factor, K = Soil Erodibility factor, L = Slope length factor, S = Slope gradient factor, C = Land cover factor, P = Management practice factor

The R-factor is defined as the product of kinetic energy and the maximum 30 minute intensity and shows the erosivity of rainfall events (Wischmeier and Smith, 1978). However, in this study, to determine the value of the R-factor, the average of annual historic rainfall event (10-years) was collected from meteorological station located at 8-Km distance from the watershed. Then the R-value corresponds to the mean annual rainfall of the watershed was found using the R-correlation established in Hurni (1985) to Ethiopia condition. Therefore, the annual R-factor for the average rainfall (650 mm) at the watershed as extrapolated from Hurni (1985) is 357. The soil erodibility (K), slope length (L), slope gradient (S), C, and P-factors of USLE for the entire watershed based on landforms and land use is presented in Table 3.

The K-factor is defined as the rate of soil loss per unit of R-factor on a unit plot (Renard et al., 1997). To determine the value of the K-factor, a systematic observation on soil color of watershed was carried out, based on the approach described in Hurni (1985). This was done by classifying the watershed into similar land uses and land forms (Table 1). For soils having different color in the same land use and landform, the K-factor was taken as their mean value of these colors as it is described on Hurni (1985). As an example, the K-factor for flat plains in Medego watershed is the mean value of the soil color black (0.15) and brown (0.2), which is about 0.18; and the same approach was used in determining the soil color for the other landforms in the watershed (Table 3). SL is the topographic factor expressed as the expected ratio of soil loss per unit area from a field slope to that from a unit plot under otherwise identical conditions. Slope length and slope gradients factors were recorded using meter tape and clinometers, respectively, in the watershed on different landform and land uses. It is taken the weighted value of the slope gradient and slope length range measured at the field for each

landform and land use and so extrapolated based on Hurni (1985) to Ethiopia condition (Table 3 and 4).

The C-factor is defined as the ratio of soil loss from land with specific vegetation to the corresponding soil loss from continuous fallow (Wischmeier and Smith, 1978). Assessment of the type of land use-cover was made separately for each land unit and the corresponding land cover was obtained from Hurni (1985) which was developed to Ethiopia condition. For variations in land cover with specific land unit or landform, the C-factor was obtained using weighted value of the different land cover (Table 3).

The P-factor gives the ratio between the soil loss expected for a certain soil conservation practice to that with up-and down-slope ploughing (Wischmeier and Smith, 1978). Specific cultivation practices affect erosion by modifying the flow pattern and direction of runoff and by reducing the amount of runoff (Renard and Foster, 1983). In areas where there is terracing, runoff speed could be reduced with increased infiltration, ultimately resulting in lower soil loss and sediment delivery. Values for this factor were assigned considering local management practices and based on values suggested in Hurni (1985). Management factors were obtained by assessing the different supporting practices in the study watershed and it was taken the weighted value for similar land forms and land uses types (Table 3). The data related to management practices were collected during the field work. The presence and status of conservation activities were assessed with emphasis on the existing conditions of terraces and protected areas. Most of the areas in the watershed are well-terraced, mainly the upslope parts. However, most of the terraces are broken due to high runoff and/or livestock trampling in many parts of the watershed.

The data were analyzed following the interpolation of the values of USLE in Hurni (1985) and Gebreselassie (1996) to Ethiopia condition. The data was then interpreted qualitatively and using descriptive statistics.

3. RESULTS AND DISCUSSION

3.1. Estimated Soil Loss Using USLE at Medego Watershed, Northern Ethiopia

In spite of the fact that tremendous efforts of SWC have been implemented, their contribution in reducing soil loss due to water erosion demands recent assessment for appropriate future conservation planning. It is understood that heavy rainfall cause severe soil erosion in agricultural fields of the semiarid regions of Ethiopia. Soil erosion in agricultural fields affects not only land productivity but also the water environment in the down stream. Many investigations have been conducted for the development of prediction methods of water-induced soil erosion processes. Among the methods, the empirical Universal Soil Loss Equation (USLE) has been applied broadly for predicting the average annual soil loss from upland fields in Ethiopia (Wischmeier and Smith, 1978; Hurni, 1985) for the reasons described in the discussion part of this paper.

The soil loss estimated using USLE on this study from cultivated land on flat plain land form (< 2% slope) of Medego watershed, northern Ethiopia is the lowest as compared to the other land uses or landforms, which is 1.59 tons ha⁻¹ y⁻¹ (Table 4). This indicates that soil loss due to rill and inter-rill erosion is almost balanced by deposition within the flat landforms of the watershed. Next to the flat land form, the landforms having lower soil erosion are undulating plains (slope 2-8%) and flat- flood prone areas (< 2% slope) which are 3.13 and 4.87 t ha⁻¹ y⁻¹, respectively. The highest soil loss at the study watershed was recorded at the landform -steep mountains (slope 30-50%), which is 35.43 tons ha⁻¹ yr⁻¹. The small soil loss rate of the landforms is related to the factors of the USLE in the watershed (Table 4). Therefore, more attention should be given to slope ranges between 30-50% while SWC measures is planning to implement in the watershed.

The general trends of the finding indicate that soil loss increases as the slope steepness increases in the watershed (Table 4). However, at the landform of very steep mountains (> 50% slope), the annual soil loss is estimated as 7.63 tons ha⁻¹, which is even less than the landforms such as rolling land forms (8-15% slope), hill landforms (15-30% slope) and steep mountains (30-50% slope). This is because these slope ranges are susceptible to daily human interferences such cultivation and grazing as compared to very steep slopes (> 50%) and also slopes having more than 50% in the watershed have land cover of 'Bad Lands Hard' and stone cover which can retain the impact of the kinetic energy of raindrops and at the

same time decrease runoff amount. Moreover, there are rock-out crops, which are difficult to detach or transport by raindrops and water erosion on the very steep escarpment of Medego watershed. Landforms more than 50% slopes are protected areas in the watershed. The C-factor represents resistance of the ground surface to the transport of water-soil mixture on the very steep mountains of the watershed includes badlands hard, and bushes and shrubs which dissipate the force of the raindrops. The P-factor stands for erosion inhibition effect, and reflects partly awareness and control measures implemented to minimize soil erosion more than the other landforms by the community (Table 3). It is also noted that the lower slope landforms are susceptible to daily human interferences where as the steepest landforms are protected areas. This proves that the USLE is useful for assessing the adequacy of conservation measures and management practices in agricultural watersheds.

The average annual soil loss estimated by USLE from the entire Medego watershed is 9.63 tons ha⁻¹. If we interpret the annual soil loss as a proxy to watershed erosion, it is possible to see that the magnitude of annual soil loss reported in Table 4 is generally higher than the tolerable soil loss of 2 – 18 tons ha⁻¹ y⁻¹ estimated for Ethiopia by (Hurni, 1985) except flat landforms of the watershed. The soil loss rate in all the landforms are below the maximum tolerable soil loss for Ethiopia condition, which is 18 tons ha⁻¹ y⁻¹, except the steep mountains (slope 30-50%) landforms that indicate almost double of the maximum soil tolerance value. In general, the average soil loss in the watershed is about half of the maximum tolerable soil loss and five times the minimum soil loss tolerance value given by Hurni (1985). The implication is that there is a need to integrate a sound management practices so that to decrease the amount of soil loss in Medego watershed, northern Ethiopia below the maximum as well as the minimum soil loss tolerable value for the country.

As compared to the soil loss estimated for Ethiopia as 42 tons ha⁻¹ y⁻¹ from cultivated fields by Hurni (1990, 1993); 21 tons ha⁻¹ y⁻¹ (Machado et al. 1995), and 30-80 tons ha⁻¹ y⁻¹ (Tekeste and Paul, 1989) in Tigray region, northern Ethiopia, the soil loss estimated on this study in 2007/08 is by far the smallest. The results of the present study as compare to past findings indicate that the amount of soil loss from a given unit of land is low. This could be due to the contribution of the

different soil conservation interventions implemented for at least the last decades in the country in general and the study watershed in particular. This related to the fact that SWC intervention increases soil moisture, fertility and decrease slope factor and thereby enhance the availability of vegetation covers. The combined effect of such factors will be decreasing the impact of raindrops, detachment and transporting of soils. This was evidenced by the opinion of the respondents which evaluated as less soil erosion after the soil conservation practices were built at the watershed as compared to before the implementation (data not presented here). Therefore, as noted in the above, the soil loss estimated by different scholars has showed discrepancy for the same environment (semi-arid region of Ethiopia). This implies that there is a need to have site specific (watershed level) information on soil erosion in order to support timely information for decision makers so that to plan the correct soil conservation planning. In doing so, it is categorized the severity of erosion in the study watershed's landforms as follows.

According to Singh and Phadke (2006) classes of soil loss range (*very slight, slight, moderate, severe and very severe*), the mean annual soil loss (9.63 tons ha⁻¹) from Medego watershed, northern Ethiopia is categorized under *slight class* of soil erosion (5 – 9.99 tons ha⁻¹ y⁻¹). According to them, the only part of the watershed landforms having *very slight class* of soil loss (0 - 4.99 tons ha⁻¹ y⁻¹) are the flat plains, undulating plains and the flat-flood prone areas; and followed by *slight soil loss* (5 – 9.99 tons ha⁻¹ y⁻¹) for the very steep escarpment of the watershed; and *moderate soil loss class* (10 – 24.99 tons ha⁻¹ y⁻¹) on rolling to hill landforms of the watershed, where as *severe class of soil loss* (25 – 44.99 tons ha⁻¹ y⁻¹) was estimated using USLE on slopes 30-50% (Table 4). This doesn't mean that to give less attention to those landforms with very slight to slight soil loss classes in the study watershed but this is to indicate that parts of the watershed landforms that need high priority for SWC implementation using the available existing resource. This is because; it may be worth noting that nature takes 200–400 years to build up 1 cm of top soil (Pimental 1995) but thousands tons of soil are lost in a season from a watershed. He also reported that each millimeters of cultivated soil loss could cost 10 kg of nitrogen and 2 kg of phosphorus per ha. Hence, this study suggests for effective control of soil erosion at specific area

which would occur under alternative management strategies and practices in order to minimize the costs related to fertilizer and environmental rehabilitation.

4. DISCUSSION

4.1. Soil Erosion Models and Their Potentials and Challenges

Soil erosion is the most serious causes of land degradation have influenced tremendous pressure on productivity and environmental stability of arid and semiarid areas. Serious impacts led the demand for conservation and management measures to reduce the magnitude of soil loss and the extent of its associated impacts in many parts of the arid and semiarid areas. There are many models in existence estimating soil erosion. The USLE has the advantage of being less data demanding than other models. A wide range of models that differ in their data requirement for model calibration, application, complexity and processes considered are available for use in predicting soil loss (Merritt et al., 2003). Physically based spatially distributed soil erosion models can be used to quantitatively determine the amount of soil loss from watersheds and also to identify critical soil loss source areas (De Roo, 1998; Emrah et al., 2007). The successful application of such models, however, depends on the availability and quality of data for calibration and validation (De Roo, 1998; Stefano et al., 1998; Takken et al., 1999). Such problems are more pronounced in developing regions where data availability is scarce, existing data are not easily accessible and data collected and stored are mostly in different formats. In addition, more complex models do not necessarily perform better for watershed-scale management purposes, mainly because input errors can increase with increasing model complexity (Favis-Mortlock, 1998; Mitas and Mitasova, 1998a; Jetten et al., 2003; Merritt, et al., 2003).

Empirical models are frequently used in preference to complex physically based models as they can be implemented in situations with limited data and parameter inputs, particularly as a first step in identifying sources and rate of soil loss (Merritt et al., 2003). However, such models

cannot be directly applied to environments other than those for which they were developed, and extrapolation of results from larger-scale plot-level to small-scale watershed level application is difficult. It is, therefore, necessary to identify models that are not very much simplified and under-represent the physical basis or not too complicated and very expensive to implement. The best example is USLE, which is identified and fit to apply in the case of the study area of Medego watershed, northern Ethiopia. The USLE is an empirically based model developed in the United States by using data on soil erosion rates. This equation has certain limitations but still is the best available method which is used most widely for estimating soil losses as average annual mass per unit area as a function of the major factors affecting sheet and rill erosion in data scarce areas of developing countries. As all landscape positions are not equally sensitive to erosion, one important approach to tackling the problem of erosion could be identifying where the sources of most of the soil loss are in a watershed (Dickinson and Collins, 1998; Kim et al., 2007). Identification of potential areas of erosion for appropriate management interventions to tackle the major causative factors at their specific locations is, therefore, imperative from an economic, management and sustainability point of view. This study was attempted in indicating the areas or landforms of high soil loss in Medego watershed, northern Ethiopia.

4.2. Soil Loss and the Influencing Factors in Medego Watershed

It is a fact that environmental degradation has been a problem in Tigray region, northern Ethiopia. The land surfaces in the region is mainly a reflection of the past erosion processes. The main causes of soil erosion in the area among others were outlined by different researchers ([Hurni, 1985; Gebresilassie, 1996, Tilahun, 1996; Tamene, 2005) and even witnessed by farmers as over-cultivation, deforestation, over grazing, steep topography, high rainfall intensity, unwise land use and management. This is evident by the huge amount of soil loss, by water erosion and very low productivity of the farm lands. Therefore, to rehabilitate the environment and enrich it to a meaningful level, a concerned effort on SWC program has been carried out by the community coordinated by of bureau of agriculture under the umbrella of the Tigray Regional Government, northern Ethiopia. In the name of SWC program, various types of physical and biological SWC measures have been undertaken in the study

watershed. These activities are: watershed treatment as area enclosure, afforestation, trench; reclamation of big gullies using check dams, biological; moisture harvesting techniques on farms and degraded grazing lands like soil, stone and trench bunds; and soil faced stone bund on hillsides.

Soil loss in different landforms of the study watershed is influenced by erosion factors differently. For instance, the soil erodibility (K) factor of the landforms in the watershed is a function of soil texture, drainage condition and soil depth. These sub-factors can influence the soil color, which determined the value of K-factor in USLE, adapted from Hurni (1985). The landforms in the watershed have different in texture, drainage condition, soil depth, soil color, land cover, erosion controlling management practices and slope factors (Table 3). Fine texture soils are dominated on flat land areas where as coarser textural class increases with increasing steepness. The same trend was observed for the soil depth with deeper soil on flat areas and shallow soil on high slope gradient landforms. The drainage condition is extremely high on steeper landforms and poor on flat area of the watershed. Therefore, the principle of Hudson (1992) that describe as fine soil particles resist to detachment by raindrops but they are susceptible to transport easily is soil drainage dependent. This is because if the landform is poor in drainage, so the probability of transporting by waters the fine particles long distance leaving the original area is too low. Transportation and deposition processes are almost balanced in such occasions. Drainage is affected by the slope factor. That is why soil loss estimated on flat landform is below the minimum tolerable soil loss ($2 \text{ ton ha}^{-1} \text{ yr}^{-1}$) determined by Hurni (1985) for Ethiopia condition. This is the lowest soil loss as compared to the other landforms in the watershed (Table 4). Sand dominant soil textures are common on higher slopes of the watershed. Even though they are coarser to transport as compared to clay texture due to high soil drainage condition of steep slopes, they are susceptible to erosion in the watershed.

Of course, the management practices in the watershed also play its own great role in the magnitude of soil loss. Landforms with well land cover indicated less soil loss. Because it dissipates the energy from rain drops and also decreases the volume and velocity of runoff effect. Soil loss estimated from landforms with very steep slope ($> 50\%$) in the study watershed is smaller than slopes

in the range of 15-30% and 30-50%. The reason is cover factors and land managements factor are better in the very steeper slopes of the watershed. This includes less human and livestock interferences, intensive terraces and relatively better vegetation cover of bushes and shrubs. Therefore, the overall implication of this study is that after the implementation of SWC measures the amount of soil loss in a given land unit is decreased in many parts of the landforms by more than 50% in the watershed as compared to the high values indicated in the past studies in northern Ethiopia (e.g., Hurni, 1985; 1990; 1993; Tekeste and Paul, 1989; Gebreselasie, 1996)). However, the present soil loss amount has also a significant influence on the overall productivity of the study watershed unless the correct measures on the targeted landforms are undertaken. This is because as compared to the soil formation in the region which is not more than $2 \text{ ton ha}^{-1} \text{ yr}^{-1}$ (Hurni, 1985); the present soil loss estimated in Medego watershed, northern Ethiopia is not neglected or it is very big. Therefore, base on the landforms identified in this study, soil conservation planning should be undertaken to address the problem of erosion in areas having large soil loss as areas of prioritization in the future.

5. CONCLUSION

The entire watershed area experienced intensive rainfall which coupled with steep gradient slopes, cause highly erosive runoff as in many other arid and semi-arid areas of Ethiopia. It is this high runoff and soil detachment that is responsible for the high rate of soil erosion at Medego watershed, northern Ethiopia that range from $1.59 - 35.43 \text{ tons ha}^{-1} \text{ y}^{-1}$. There is a need to regulate this soil loss by all possible means so as to decrease the existing amount of soil loss and enhancing watershed rehabilitation and productivity. Suggested watershed rehabilitation as long and short-term measures should be included the following: As long-term measures re-vegetation of denuded hill slopes with trees and perennial grasses such as vetiver strips and belts; introduction of an agro-forestry program that is compatible with crop, livestock; and forestry development; where as short-term soil and water conservation measures are given due attention to: cut-off drains which need to construct that intercept runoff; constructing and maintenance stone and soil bund and trenches on proper slopes and soils and integrating with vegetation intensively. This has to include interventions such

as inter-bund management, bund stabilization, buffer zone establishment and re-bank re-vegetation; and gully control by both vegetative and structural measures should be being intensively implemented.

As a result of the implementation of SWC, the hydrological behavior of the watersheds is improved such as base flow in streams and springs increased, sediment load to reservoirs reduced, crop yield improvement due to soil moisture enhancement, vegetation cover improvement and increased availability of forage for livestock were observed. These are some of the indicators of the effectiveness of the implemented soil and water conservation practices in the study watershed. However, maintenance of the existing SWC and introducing additional appropriate land management practices and rules should be given attention by concerned bodies in order to decrease and totally stop the rate of soil loss and then to increase the total biomass production in the watershed, even though the biggest rate ($35.43 \text{ tons ha}^{-1} \text{ yr}^{-1}$) of soil loss is coming from landforms having slopes 30-50% and the lowest soil loss is from slope less than 2%. Therefore, to maximize the available resources in targeting the effect of water erosion on soil loss, those landforms and land uses having large rate of erosion should be given first priority during the introduction of intensive and well designed SWC interventions at Medego watershed, northern Ethiopia.

Acknowledgements

This research was conducted with the financial support provided by Ethiopia Science and Technology Agency Research Support Program and Axum University, Ethiopia. The authors thanks for the financial support of the organizations.

Corresponding author

Gebreyesus Brhane

Center for Development Research (ZEF),
University of Bonn, Walter-Flex-Str. 3,
D-53113 Bonn, Germany
phone: ++49 (0)162 4722826; Fax: ++49 (0)228-73-5097;

e-mail: gebre042001@yahoo.com

REFERENCES

1. Bartsch KP, Van Miegroet H., Boettinger J, Dobrowolski, JP. Using empirical erosion models and GIS to determine erosion risk at Camp Williams. *Journal of Soil and Water Conservation* 2002; 57(1):29–37.
2. Boardman J. An average soil erosion rate for Europe: myth or reality? *Journal of Soil and Water Conservation* 1998; (2)53:46-50.
3. BoARD, Bureau of Agriculture and Rural Development. Annual report. Tigrigna (local language) version. Axum, Ethiopia. 2007: 4-18.
4. Chekun T. Vetiver in the Rehabilitation of the Degraded ZegZeg Watershed in Ethiopia, Addis Ababa, Ethiopia. Report, 2002:131-136.
5. De Roo APJ. Modelling runoff and sediment transport in catchments using GIS. *Hydrological Processes* 1998;12:905-922.
6. Emrah HE, Günay E, İlhami B. Use of USLE/GIS Methodology for Predicting Soil Loss in a Semiarid Agricultural Watershed. *Environmental Monitoring and Assessment* 2007;131(1-3):153–161.
<http://www.springerlink.com/content/rx032v53753w4367/fulltext.pdf>. Accessed 18 Dec. 2008.
7. Favis-Mortlock DT. Validation of field-scale soil erosion models using common datasets. In: Boardman J and Favis-Mortlock DT (Eds.) *Modelling Soil Erosion by Water*, Springer-Verlag NATO-ASI Series I-55, Berlin. 1998: 89-128.
8. Ferro V, Porto P, Tusa G. Testing a distributed approach for modeling sediment delivery. *Hydrological Sciences Journal* 1998; 43(3): 425-442.
9. FAO/UNEP. *Methodology for Assessing Soil Degradation*, FAO/UNEP, New York, 1978:49–55.
10. FAO. *Ethiopian Highland Reclamation Study*. Ethiopia. Final report. FAO. Rome. 1986:37-46.
11. Gebreselasie ED. *Soil erosion hazard assessment for land evaluation*. Soil Conservation Research Program, University of Bern, Switzerland and the Ministry of Agriculture, Ethiopia. MSc Thesis, 1996:68-82.
12. Hudson N. *Land Husbandry*. B T Batsford Limited, London. 1992:172-190.
13. Hurni H. Soil erosion and soil formation in agricultural ecosystems in Ethiopia and Northern Thailand. *Mountain research and development* 1983; 3(2):131-142.
14. Hurni H. Erosion - Productivity - Conservation Systems in Ethiopia. *Proceedings 4th International Conference on Soil Conservation*, Maracay, Venezuela 1985: 654-674.
15. Hurni H. Degradation and conservation of soil resources in the Ethiopian highlands. *Mountain and Research Development* 1990;8 (2-3): 123-130.
16. Hurni H. Land degradation, famine, and land resource scenarios in Ethiopia. In: Pimentel D. (Ed.) *World soil erosion and conservation*. Cambridge Univ. Press. 1993:89-97.
17. Jetten V, Govers G, Hessel R. Erosion models: quality of spatial predictions. *Hydrological Processes* 2003;17(5):887 – 900.
18. Judson S. *Physical Geology*, Prentice Hall, NJ, USA, 3rd ed., 1965:143–144
19. Kim M, Flanagan DC, Frankenberger JR, Jung K.. Regional Scale Application of USLE and WEPP for Soil Erosion Assessment in Korea [abstract]. 2007 American Society of Agricultural and Biological Engineers Annual International Meeting. June 17-20, 2007, Minneapolis, MN. Paper No. 072048.
20. Lal R. Erosion Impact on Soil quality in the Tropics. In Lal (Ed.): *Soil Quality and Soil Erosion*. CRC press, Boca Raton, Florida. 1999: 285-317.
21. Machado MJ, Perez-Gonzalez A, and Benito G. Geomorphology and soils. In: Feoli E (Ed.) *Rehabilitation of degrading and degraded areas of Tigray, northern Ethiopia*. Department of Biology, University of Trieste, Trieste, 1996:65-106.
22. Merritt WS, Letcher RA, and Jakemna AJ. A review of erosion and sediment transport models. *Environmental Modelling and Software* 2003;18(8-9): 761-799.
23. Mirco G, Robert JA.J, Ezio R, Luca M. Soil Erosion Risk in Italy: a revised USLE approach. *European Soil Bureau Research Report No.11*, EUR 20677 EN. Office for Official Publications of the European Communities, Luxembourg. 2003:28.
24. Mitas L, Mitasova H. 1998 Distributed soil erosion simulation for effective erosion prevention. *Water Resources Research*. 1998;34(3): 505-516.
25. Phillips JD. Hillslope and channel sediment delivery and impacts of soil erosion on water resources. In Hadley RF and Ongley EO (Eds.) *Sediment and the Environment IAHS Publ.* 1989;23(184):183-190.

26. Pimental DC. Environmental and economic cost of soil erosion and conservation benefits. *Science* 1995;267(5201):1117–1123.
27. Renard KG, Foster GR. Soil conservation: principles of erosion by water. In: Degne HE and Willis WO (Eds.) *Dryland Agriculture*, Agronomy Monogr. 23, Am. Soc., Crop Sci. Soc. Am., and Soil Sci. Am Madison, Wisconsin, 1983:156-176.
28. Renard KG, Foster GR, Weesies GA, McCool DK, Yoder DC. Predicting soil erosion by water: a guide to conservation planning with the Revised Universal Soil Loss Equation (RUSLE). *USDA Agricultural Handbook 703*, 1997:126-131.
29. Singh R, Phadke VS, 2006. Assessing soil loss by water erosion in Jamni River Basin, Bundelkhand region, India, adopting universal soil loss equation using GIS. *Current Science*, 2006; 90(10): 25 –27.
30. Stefano CD, Ferro V, Porto P. Linking Sediment Yield and Caesium-137 Spatial Distribution at Basin Scale. *Journal of Agricultural Engineering Research* 1998;74 (1): 41-62.
31. Sutcliffe JP. Economic assessment of land degradation in the Ethiopian highlands: A case study. National Conservation Strategy Secretariat, Ministry of Planning and Economic Development, Addis Ababa, 1993.
32. Takken I, Beuselinck L, Nachtergaele J, Govers G, Poesen J, Degraer G. Spatial evaluation of a physically-based distributed erosion model (LISEM). *Catena* 1999;37(3-4): 431-447.
33. Tamene L. Reservoir siltation in the drylands of northern Ethiopia: causes, source areas and management options. PhD Thesis, Ecology and Development Series 30, Center for Development Research, University of Bonn. 2005:84-138.
34. Tekeste G, Paul DS. Soil and water conservation in Tigray, Ethiopia. Report of a consultancy visit to Tigray. Univ. Wageningen. 1989:78.
35. Tilahun Y. Impacts of conservation bunds on crop yields in Degua Tembien, northern Ethiopia. MSc Thesis, Agricultural University of Norway (NLH). 1996: 53-82.
36. Wischmeier WH, Smith DD. Predicting rainfall erosion losses – a guide for conservation planning. U.S. Department of Agriculture, *Agriculture Handbook* 537. 1978:20-152.
37. Zeleke G, Humi H. 2001. Implications of land use and land cover dynamics for mountain resourcedegradation in the Northwestern Ethiopian highlands. *Mountain Research and Development* 2001;21(2): 184-191.

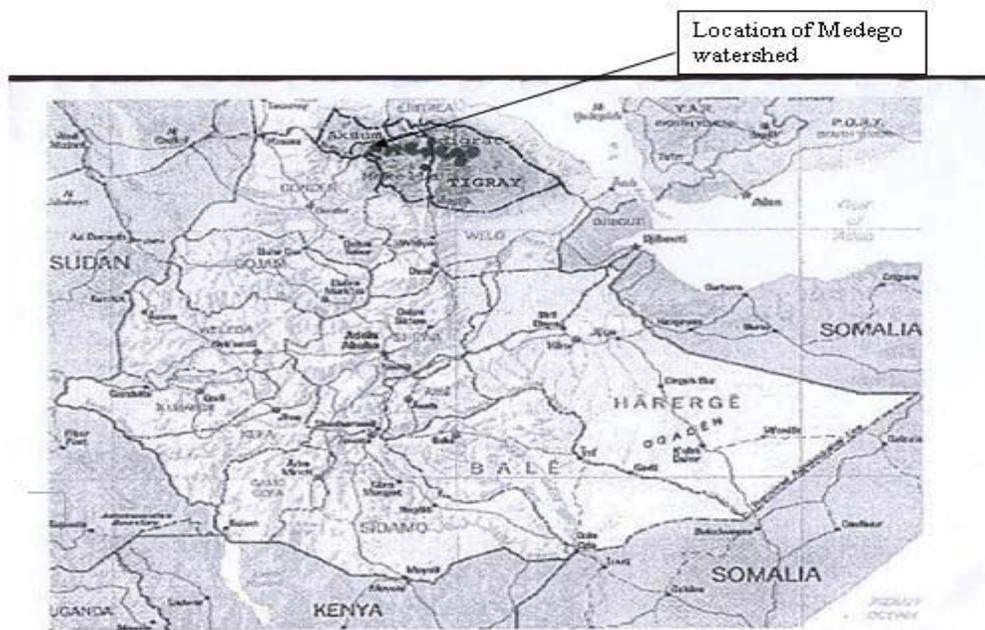

Fig 1: Map of Ethiopia with Tigray region and Medego watershed outlined.

Table 1

Land forms and their area coverage in Medego watershed, Lalay-Maychew district, northern Ethiopia.

| land forms/ features | Slope range (%) | Area coverage (ha) |
|------------------------|-----------------|--------------------|
| Flat plains | < 2 | 200 |
| Undulating plains | 2-8 | 300 |
| Rolling land | 8-15 | 50 |
| Hill to rolling | 15-30 | 290 |
| Steep Mountains | 30-50 | 200 |
| Very steep escarpment | >50 | 50 |
| Flat, flood prone area | < 2 | 15 |
| Total | | 1091.5 |

Table 2.

Farmers own ranking of important tree and shrub in the order of importance at Medego watershed, Lalay-Maychew district, northern Ethiopia.

| Column number* | 1 | 2 | 3 | 4 | 5 | 6 | 7 | 8 | 9 | 10 | 11 | 12 |
|---|------------------|--------|------------|---------|-----------|----------|--------------|------------|-------------------|---------|-------|------------|
| Species use for | Soil improvement | fodder | Bee forage | fencing | Fire wood | charcoal | Construction | Hand tools | Soil conservation | shading | total | Score/rank |
| Che'el/ <i>Acacia abyssinica</i> | 1 | 3 | 4 | 4 | 4 | 2 | 2 | 4 | 3 | 3 | 30 | 4 |
| Seraw/ <i>Acacia etbaica</i> | 3 | 2 | 1 | 2 | 5 | 5 | 1 | 4 | 3 | 3 | 29 | 6 |
| Acacha/ <i>Acacia decurrens</i> | 3 | 5 | 4 | 3 | 4 | 3 | 4 | 1 | 3 | 4 | 34 | 1 |
| Eika/ <i>Agave sisalana</i> | - | 1 | 2 | 5 | - | - | 1 | - | 5 | - | 14 | 11 |
| Ere/Abe bethana | - | 1 | 4 | 4 | - | - | - | - | 5 | - | 14 | 11 |
| Tebeb/ <i>Bacium gradiflorum</i> | 4 | - | 5 | - | 2 | - | 1 | - | 3 | - | 15 | 9 |
| Agam/ <i>Carrissa edulis</i> | 2 | 1 | - | 3 | 3 | 1 | 1 | 1 | 2 | 1 | 15 | 9 |
| Tahsus/ <i>Dodonea angustifolia</i> | 3 | 2 | 3 | 3 | 3 | 4 | 3 | 5 | 4 | 3 | 33 | 3 |
| Bahrizaf/ <i>Eucalyptus comoidulensis</i> | 3 | 5 | 2 | 1 | 4 | 3 | 5 | 3 | 2 | 2 | 30 | 4 |
| Kullual/ <i>Euphorbia abyssinica</i> | - | - | 3 | 5 | 1 | - | 3 | - | 4 | 4 | 20 | 7 |
| Awlie/ <i>Olea europea</i> | 2 | 1 | 2 | 1 | 5 | 5 | 5 | 5 | 3 | 5 | 34 | 1 |
| Beles/ <i>Opuntia ficus indica</i> | - | 5 | 2 | 4 | - | - | - | - | 5 | - | 16 | 8 |

- = no/zero value; *(1-5) = 1 with the lowest value and 5 with the highest value for column 1 up to 10 but it is the reverse of this in column 12 which is the top rank starts with 1 and the last/lowest rank ends with 11. Column 11 is sum of columns 1 up to 10.

Table 3
Selected soil characteristics, average slope length (L) and gradient (S), land cover (C) and management (P) practices collected for different landforms at Medego watershed, northern Ethiopia

| Landform | Soil color | Ave. L (m) | Ave. S (%) | C-factor* | P-factor* | Soil depth | texture | drainage |
|------------------------|------------------|------------|------------|---|---|--------------------------------------|-------------|----------------|
| Flat plains | Black and brown | 25 | 2% | Ethiopian teff (0.25) | Ploughing on contour (0.90)* | deep | Clay loam | poor |
| Undulating plains | Black and red | 22 | 5 | Cereal, Ethiopian teff and degraded grass (0.15) | Ploughing on contour and strip cropping (0.73) | Moderately deep | Sandy loam | moderately |
| Rolling land | Brown and red | 18 | 12 | Badlands soft, pulses and degraded grass (0.2) | Ploughing on contour, stone cover 40% and terraces (0.73) | shallow | Sandy silt | High |
| Hill to rolling | Brown and yellow | 25 | 15 | Scattered forest, degraded grass, badlands soft and bush (0.13) | Stone cover 40%, protected areas and terraces (0.63) | Very shallow | sandy | Extremely high |
| Steep mountains | Red and yellow | 15 | 40 | Scattered forest and badlands soft (0.22) | Stone cover 80%, protected areas and terraces (0.53) | Extremely shallow | sandy | Extremely high |
| Very steep mountains | yellow | 10 | 60 | Badlands hard and bushes/shrub (0.04) | Stone cover 80% and terraces (0.53) | Extremely shallow and rock out crops | Coarse sand | Extremely high |
| Flat, flood prone area | black | 20 | 2 | Dense forest and Ethiopian teff (0.13) | Dense intercropping (0.7) | Very deep | clay | Extremely poor |

* Numbers in parenthesis are the mean values of more than two C or P practices based on interpolation from Humi (1985) and Gebresilassie (1996).

Table 4.
KLSCP factors values adapted based on Humi (1985); Gebresilassie (1996) to land forms and land use at Medego watershed, northern Ethiopia. R factor is 357 for all landforms in the watershed.

| Landform | land use | K-factor | L-factor | S-factor | C-factor | P-factor | tons ha ⁻¹ y ⁻¹ |
|------------------------|---|----------|----------|----------|----------|----------|---------------------------------------|
| Flat plains | cultivated | 0.18 | 1.1 | 0.1 | 0.25 | 0.90 | 1.59 |
| Undulating plains | cultivated; some grazing | 0.20 | 1.0 | 0.4 | 0.15 | 0.73 | 3.13 |
| Rolling land | cultivated; some grazing | 0.23 | 0.9 | 1.0 | 0.20 | 0.73 | 10.88 |
| Hill to rolling | scattered natural forest, reforestation, grazing and area closure, some marginal area | 0.25 | 1.1 | 1.6 | 0.13 | 0.63 | 12.86 |
| Steep mountains | grazing area, some closed area, marginal area | 0.28 | 0.8 | 3.8 | 0.22 | 0.53 | 35.43 |
| Very steep mountains | Protected area with bushes/shrubs | 0.30 | 0.7 | 4.8 | 0.04 | 0.53 | 7.63 |
| Flat, flood prone area | Rain fed and irrigated land, dense eucalyptus trees and check dams and biological measures in gullies | 0.15 | 1.0 | 0.1 | 0.13 | 0.70 | 4.87 |
| Mean soil loss | | | | | | | 9.63 |

Conservation through *in vitro* method: A case of plant regeneration through somatic embryogenesis in *Quercus semecarpifolia* Sm.

¹Sushma Tamta , ²Lok Man S. Palni, ²P. Vyas and ²M.S.Bisht

¹Botany Department, D. S. B. Campus, Kumaun University, Nainital, UA, 263 002, India.

²G.B.Pant Institute of Himalayan Environment and Development, Kosi-Katarmal, Almora, UA, 263 643, India

An efficient and reproducible protocol for *in vitro* propagation via somatic embryogenesis (direct as well as indirect) induced on cotyledon halves (with embryo) taken from seeds of *Quercus semecarpifolia* (Sm.) has been developed. Direct as well as indirect somatic embryogenesis was induced from the cotyledons on Woody plant (WP) medium supplemented with 6-Benzyladenine (BA) + Indole-3-butyric acid (IBA), and, BA + 2,4-Dichlorophenoxyacetic acid (2,4-D), respectively. Somatic embryos thus obtained were multiplied profusely on Schenk and Hildebrandt (SH) + Murashige and Skoog (MS) basal as well as BA supplemented media. Germination and conversion of somatic embryos into plantlets was achieved on SH+MS medium supplemented with BA (0.44- 8.88 μ M). Rooting of *in vitro* produced shoots was achieved on WP (1/2 macro + full concentration of rest of the constituents) medium supplemented with IBA (14.76 μ M). The plants were hardened *ex-vitro* and transferred to earthen pots containing garden soil. [Journal of American Science 2009: 5(1), 70-76] (ISSN: 1545-1003)

Key words: *Quercus semecarpifolia*, brown oak, somatic embryogenesis, micropropagation.

1. INTRODUCTION

The genus *Quercus* has a wide distribution range; mostly trees, either deciduous or evergreen and is of enormous ecological and economical value. One of the species of *Quercus*, i.e., *Quercus semecarpifolia* Sm. (family-Fagaceae); common name-brown or kharsu oak; is the main forest forming evergreen tree species around 2400 m amsl in parts of Indian Himalaya (Singh and Singh, 1987). In view of the general importance of this species and problems associated with its regeneration (Tamta et al. 2008), in the present study attempt has been made for the first time to develop an efficient *in vitro* micropropagation method through somatic embryogenesis.

Micropropagation through somatic embryogenesis offers considerable advantages over other methods of clonal propagation; this route has a high proliferation potential. It has been considered as a very promising method of oak micropropagation (Chalupa, 1995, Wilhelm 2000, Purohit et al.2002), and was found to be highly reproducible in this study on *Q. semecarpifolia*. Efficient protocols on SE induction and plant

regeneration have recently become available for many plant species, including *Arabidopsis thaliana*, a model plant in genetics and embryogenesis (Gaj, 2004).

2. MATERIALS AND METHODS

Plant material and surface sterilization

Seeds of *Quercus semecarpifolia* Sm. were collected from well grown adult tree in the natural forests at Kilbury, Nainital (2100-2400 m amsl; 29° 24' 30" N- 29° 27' N lat. and 79° 25' E- 79° 29' 40" E long.), Uttarakhand, India. Following surface disinfection (Tamta et al. 2008), the seed coat was removed and seeds were divided into two halves; one half containing only one cotyledon while the other half contained the other cotyledon along with the embryo. These seed halves were used as explants for inoculation.

Media and culture establishment

Three basal media, namely MS (Murashige and Skoog, 1962), WP (Lloyd and McCown, 1980) and SH+MS, i.e., a combination of macronutrients

of SH (Schenk and Hilderbrandt, 1972) and the remaining constituents of MS, were used. The basal media were supplemented with various concentrations of auxins, cytokinins and gibberellins. The sucrose concentration was 3.0% (w/v) and the media were solidified with 0.8% agar (w/v). The experiments were done using glass petridishes (10 cm dia, 25 ml medium per petridish) or conical flasks (250 ml volume, 100 ml medium per flask). Incubation of cultures was carried out at 25 ± 1 °C in a 16 h light and 8 h dark cycle, with $42.0 \mu\text{mol m}^{-2}\text{s}^{-1}$ and $60.0 \mu\text{mol m}^{-2}\text{s}^{-1}$ irradiance inside and outside the culture flasks, respectively by cool fluorescent tubes (Philips TI 40 W/54).

Production of somatic embryos

Seed halves turned green when inoculated on WP basal medium. After seven days, cotyledons with or without the zygotic embryo, were transferred on to WP or MS medium supplemented with either BA (0.44 μM) alone or in combination with 2,4-D (4.53 μM) or IBA (4.92 μM) or GA₃ (2.89 μM). Direct as well as indirect somatic embryogenesis with the intervening callus phase was induced within 13 weeks and 18 (10 weeks for callus establishment and proliferation + 8 weeks for induction of somatic embryos) weeks of culture, respectively. In both the cases, the presence of zygotic embryo seems to have some role in the production of somatic embryos. The callus raised from cotyledons without the zygotic embryos did not survive on further subculture and degenerated. For germination of somatic embryos, formed both from the direct as well as indirect pathways, SH+MS medium supplemented with BA (0.44-8.88 μM) was used. The somatic embryos germinated to form well developed shoots, leaves and tap root system.

Adventitious rooting of microshoots

The survival rate of plantlets thus obtained; after transfer to *ex vitro* conditions was very poor (data not shown). Therefore, the main tap root was excised and the shoots were transferred to the rooting medium, i.e., WP (1/2 macro + full concentration of rest of the constituents) or SH + MS (macro of SH + rest of the constituents of MS) media supplemented with different auxins (Table 4), containing sucrose (3.0%; w/v) and phytigel (0.25%; w/v). Well developed adventitious roots were found to form within 4 weeks.

Transfer of plantlets to soil

After 5 weeks, the shoots with well developed roots were taken out from the culture flasks, the roots gently washed with water to remove traces of phytigel and the plantlets were then transferred to small plastic cups (8.0 cm ht; 7.0 cm dia) containing garden soil and the cups were covered with a transparent polythene sheet. Plants were kept inside a polyhouse for acclimatization for 1 month. After that the plants were transferred to the earthen pots (18 cm high; 20 cm dia) containing the same soil.

Statistical analyses

Experiments were conducted using a randomized block design to determine the effect of treatments and were repeated as described in individual experiments. For all the experiments explants were used in triplicates.

3. RESULTS AND DISCUSSION

Direct somatic embryogenesis

Globular structures were found to develop directly on the periphery of cotyledons with attached zygotic embryo, after 13 weeks on WP medium supplemented with BA and IBA (Table 1). These structures were loosely attached to the surface of cotyledons (Fig. 1A). On subculture these globular structures were converted into bipolar somatic embryos (Fig. 1B). This has been reported in some other species of *Quercus* (Chalupa, 1995; Gingas and Lineberger, 1989). Bipolar somatic embryos were also observed in *Q. robur* (Cuenca et al., 1999) and in *Q. suber* (Puigderrajols et al., 1996), which were reported to be translucent or opaque-white in appearance. These somatic embryos were multiplied by secondary embryogenesis (Fig. 1C), and the frequency of secondary embryo formation was found to increase when subcultured on SH+MS medium, without any growth regulators. In *Q. suber* also secondary embryogenic lines were maintained on medium lacking PGRs (Fernandez-Guijarro et al., 1995). Proliferation of secondary embryos was most prolific from the root pole of the somatic embryos. Secondary embryos were produced mostly from the root pole end of the primary embryos as also observed by El Maataouti et al. (1990) and Gingas (1991). Cotyledons without the embryonic axes failed to give rise to direct embryos.

Indirect somatic embryogenesis

Callus was induced from the surface of cotyledons inoculated on both MS or WP media supplemented with BA and 2,4-D or IBA (Table 1). The creamy yellow callus developed on MS medium was slow to proliferate and degenerated on further subcultures. On the other hand friable callus was formed on WP medium after 10 weeks on cotyledonary halves with embryo (Fig. 1D); subsequently this callus was subcultured on MS basal medium (half or full strength) supplemented with CH (0.02%, w/v) and activated charcoal (1.0%, w/v) (Table 2). The friable callus developed on WP medium supplemented with BA (0.44 μ M) and 2,4-D (4.53 μ M) (Table 1) was found to turn embryogenic after 8 weeks (two months) of subculture (Table 2; Fig. 1E) when transferred to the above medium, i.e., MS basal (half or full strength) medium supplemented with CH (0.02%; w/v) + AC (0.1%; w/v). Somatic embryos could be multiplied through secondary embryogenesis on SH + MS medium supplemented with BA (0.44-8.88 μ M) (Table 3). BA, a potent cytokinin, alone or in combination with auxins, particularly IBA or 2,4-D, has been known to induce somatic embryogenesis from the zygotic embryos (Chalupa, 1995; Gingas and Lineberger, 1989; Sasamoto and Hosoi, 1992; Kim et al. 2006). Somatic embryos of all stages (globular, heart and torpedo shaped) could be observed on the same medium.

The rate of multiplication of somatic embryos through secondary embryogenesis varied from 1.66 to 3.14 secondary embryos per somatic embryo, over a period of 5-6 weeks, depending upon the PGR supplements (Table 3). It is often reported in case of *Quercus* that calli turn embryogenic when transferred to the basal medium (Gingas and Lineberger, 1989; Guijarro et al., 1995; Kim et al., 1994).

Germination of somatic embryos

Somatic embryos (produced from the direct as well as indirect pathways) were transferred to BA (0.44-8.88 μ M) supplemented SH+MS medium for germination. Some of the somatic embryos germinated and produced root and shoot in a well coordinated manner (Fig. 1F). In a number of somatic embryos only the root primordia elongated (Fig. 1G); its frequency varied from 4.0-27.0 per cent depending upon the concentration of BA in the medium. The overall conversion frequency of somatic embryos was only around 10 per cent. BA at 2.22 μ M was found to be optimum for germination and conversion of somatic embryos into plantlets (Table 3). The frequency of

conversion of somatic embryos into full plants in oaks is usually quite low (Chalupa, 1995); this is a matter of future investigations. Fig. 1H shows the germination of somatic embryo.

Adventitious rooting of microshoots excised from germinating somatic embryos

Out of various media tried (MS, WP, SH+MS) supplemented with various auxins (IAA, NAA, IBA) in different concentrations (4.92 μ M - 28.55 μ M), WP medium supplemented with IBA (14.76 μ M) was found to be most effective (100.0%) in inducing rooting without any callus formation at the basal end (Table 4). The root initials were observed within 10 days and well developed roots were formed in four weeks (Fig. 1I). The average number of roots was 12.46 with maximum length of 6.97 cm (Fig. 1J). WP medium supplemented with NAA or IAA also induced rooting (16.6% and 50.0%, respectively). However, the average number of roots was 3.0 and 3.02 and the length of the longest roots were 0.2 and 2.2 cm, respectively. When IBA was added to SH+MS medium, this combination also induced rooting (100.0%) but the formation of callus was invariably seen at the base of the explant, and the average number of roots (4.3) and length of the longest root (0.21 cm) were also considerably less. The addition of NAA to SH+MS medium totally failed in inducing rooting, whereas IAA induced rooting in 40.0% shoots with the average number roots being 4.0. However, the roots did not elongate and the length of the longest root never exceeded beyond 0.2 cm. Secondary roots were found to develop only on WP medium supplemented with IBA with profuse adventitious rooting. Addition of IBA to the rooting medium gave better results in comparison to another auxin, NAA, in *Q. suber* (Manzanera and Pardos, 1990) also.

Hardening: Well rooted plants were taken out of the culture vessels and the adhering phytigel was carefully removed; the delicate roots were then gently and thoroughly washed before transferring to plastic cups containing garden soil (Fig. 1K). The survival of these plants was only 20.0 per cent. After one month, these plants were transferred to earthen pots containing same soil and maintained inside the polyhouse until new leaves were found to emerge (Fig. 1L). In conclusion, the present study describes, for the first time, the effective multiplication protocol for *in vitro* propagation of *Q. semecarpifolia*.

Table 1
Effect of treatments on seed halves of *Q. semecarpifolia* in different media

| S. No. | Treatments | MS medium | WP medium |
|--------|---------------------------------------|-----------|-----------|
| 1 | Control | - | - |
| 2 | BA (0.44 µM) | - | - |
| 3 | BA+2,4-D (0.44 µM+4.53 µM) | Callus | Callus* |
| 4 | BA+IBA (0.44 µM+4.92 µM) | Callus | Direct SE |
| 5 | BA+ GA ₃ (0.44 µM+2.89 µM) | - | - |

*embryogenic callus, - nil, SE: somatic embryogenesis, data recorded after 10 weeks of culture for callus formation and after 13 weeks for direct somatic embryo formation

Table 2
Callus proliferation and somatic embryogenesis in *Q. semecarpifolia*

| Medium constituents | Callus Proliferation | Embryogenesis | No. of embryos/ petri dish |
|------------------------------|----------------------|---------------|----------------------------|
| MS | ++ | *** | 125 |
| MS+CH (0.02%) | +++ | ** | 96 |
| MS+CH (0.02%) +AC (0.1%) | + | - | NA |
| 1/2 MS + CH (0.02%) | + | - | NA |
| 1/2MS+CH (0.02%) + AC (0.1%) | ++ | *** | 110 |

The callus was initiated on WP medium supplemented with BA and 2,4-D; MS: Murashige and Skoog medium; CH: Casein hydrolysate, AC: activated charcoal, all concentrations are w/v basis; + poor, ++ medium, +++ prolific; * poor, ** moderate, *** abundant, - nil, NA: not applicable; data recorded after 8 weeks (2 months) of culture; 6 petridishes were used per treatment with 4 callus pieces per petridish; the experiment was repeated twice with similar results

Table 3
Response of somatic embryos of *Q. semecarpifolia* on SH+MS medium supplemented with various concentrations of BA

| BA (μM) | No. of somatic embryos transferred | Germination of somatic embryos (%) | of Secondary embryogenesis* | Frequency of root formation (%) |
|---------|------------------------------------|------------------------------------|-----------------------------|---------------------------------|
| 0.44 | 30 | 0 | 1.66 | 26.60 |
| 0.88 | 97 | 4.50 | 2.28 | 18.40 |
| 1.78 | 44 | 5.20 | 3.14 | 18.18 |
| 2.22 | 49 | 6.90 | 3.00 | 14.00 |
| 4.44 | 68 | 2.90 | 1.85 | 4.40 |
| 8.87 | 90 | 0.89 | 1.76 | 4.10 |

* No. of total somatic embryos after six weeks/no. of somatic embryos initially inoculated per flask; each treatment consisted of 12 flasks, data was recorded 6 weeks after transfer of somatic embryos to the medium. The experiment was repeated twice with similar results.

Table 4
Effect of auxins and media on *in vitro* rooting of SE derived microshoots of *Q. semecarpifolia*

| Medium | PGRs (conc.in μM) | Shoot ht (cm) ±SD | % callusing | % rooting | No. of roots/shoot ±SD | Length of longest root (cm)±SD | Sec. roots |
|--------|-------------------|-------------------|-------------|-----------|------------------------|--------------------------------|------------|
| WP | IBA (14.76) | 2.20 ±1.04 | 0.00 | 100.00 | 12.46 ±4.87 | 6.97 ±1.47 | + |
| | NAA(16.11) | 1.33 ±0.68 | 100.00 | 16.60 | 3.00 ±1.22 | 0.20 ±0.03 | - |
| | IAA (17.13) | 2.17 ±0.69 | 0.00 | 50.00 | 3.02 ±4.24 | 2.20± 0.57 | - |
| SH+MS | IBA (14.76) | 2.56 ±0.42 | 100.00 | 100.00 | 4.30 ±2.07 | 0.21 ±0.13 | - |
| | NAA (16.11) | 1.93 ±0.89 | 48.00 | 0.00 | NA | NA | NA |
| | IAA (17.13) | 2.00 ±1.31 | 0.00 | 40.00 | 4.00 ±2.3 | 0.20 ±0.11 | - |

WP: 1/2 macro + full concentrations of rest of the constituents; SH+MS : macro (SH) + rest of the constituents of MS; SE: somatic embryo, +: occurred; -: did not occur; NA: not applicable; SD: standard deviation, data recorded 5 weeks after transfer to rooting medium, treatments were carried out in triplicate and each flask contain 9 microshoots

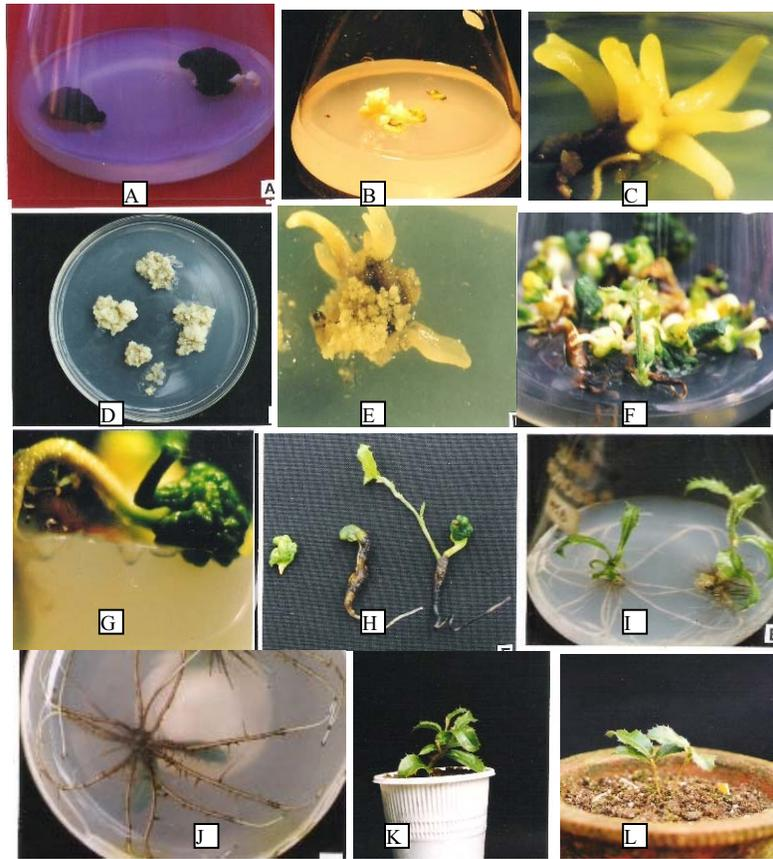

Fig. 1. *In vitro* propagation of *Q. semecarpifolia*

- (A) Globular structures loosely attached to the surface of the cotyledon.
- (B) Bipolar somatic embryos
- (C) Secondary embryogenesis
- (D) Friable embryogenic callus on WP medium
- (E) Indirect somatic embryogenesis
- (F) Germination of somatic embryo
- (G) Elongation of root primordia from the somatic embryo
- (H) Different stages of somatic embryo germination
- (I) Well rooted plantlets after 4 weeks of culture on WP medium supplemented with IBA
- (J) Rooting from basal view
- (K) Well rooted plant 1 month after transfer to plastic cup containing garden soil
- (L) Two –months-old *in vitro* propagated plant in earthen pot

ACKNOWLEDGEMENT

The financial support received from the Department of Biotechnology, Govt. of India, is gratefully acknowledged.

Corresponding Author:

Dr (Mrs) Sushma Tamta,
Lecturer, Botany Department,
D. S. B. Campus, Kumaun University, Nainital,
Uttarakhand, 263 002, India.
Email: sushma_tamta@yahoo.com
Telephone:9412924956

REFERANCES

1. Chalupa V (1995) Somatic embryogenesis in oak (*Quercus* spp.). In: Jain S, Gupta P, Newton R (eds) Somatic embryogenesis in Woody Plants. Angiosperms. Kluwer Academic Publishers, Dordrecht, The Netherlands, vol. 2, pp 67 – 87
2. Cuenca B, San-Jose MC, Martinez MT (1999) Somatic embryogenesis from stem and leaf explants of *Quercus robur* L. Plant Cell Rep. 18: 538-543
3. El Maataoui M, Espagnac H, Michaux-Ferriere N (1990) Histology of callogenesis and somatic embryogenesis induced in stem fragments of cork oak (*Quercus suber*) cultured *in vitro*. Ann. Bot. 66: 183-190
4. Fernandez-Guijarro B, Celestino C, Toribio M (1995) Influence of external factors on secondary embryogenesis and germination in somatic embryos from leaves of *Quercus suber*. Plant Cell Tiss. Org. Cult. 41: 99-106
5. Gaj DM (2004) Factors influencing somatic embryogenesis induction and plant regeneration with particular reference to *Arabidopsis thaliana* (L.) Heynh. Plant Growth Regulation. 43(1): 27-47
6. Gingas VM (1991) Asexual embryogenesis and plant regeneration from male catkins of *Quercus*. Hort. Sci. 26: 1217-1218
7. Gingas VM, Lineberger RD (1989) Asexual embryogenesis and plant regeneration in *Quercus*. Plant Cell Tiss. Org. Cult. 17: 191-203
8. Guijarro FB, Celestino C, Toribio M (1995) Influence of external factors on secondary embryogenesis and germination in somatic embryos from leaves of *Quercus suber*. Plant Cell Tiss.Org. Cult. 41: 99-106
9. Kim YW, Lee BC, Lee SK, Jang SS (1994) Somatic embryogenesis and plant regeneration in *Quercus acutissima*. Plant Cell Rep. 13: 315-318
10. Kim Y, Moon H, Son S (2006) Repetitive somatic embryogenesis and plant regeneration in *Zizyphus jujube* Mill. In Vitro Cell Dev Bio Plant. 42(3): 247-251
11. Lloyd G. and McCown B. (1980) Commercially feasible micropropagation of mountain laurel, *Kalmia latifolia*, by shoot tip culture. Comb. Proc. Intl. Plant Prop. Soc. 30: 421-427.
12. Manzanera J.A. and Pardos J.A. (1990) Micropropagation of juvenile and adult *Quercus suber* L. Plant Cell Tiss. Org. Cult. 21: 1 – 8.
13. Murashige T. and Skoog F. (1962) A revised medium for rapid growth and bioassays with tobacco tissue culture. Physiol. Plant. 15: 473 – 497.
14. Puigderrajols P, Fernandez-Guijarro B, Toribio M, Molinas M (1996) Origin and early development of secondary embryos in *Q. suber* L. Int. J. Plant Sci. 157: 674-684
15. Purohit V.K., Palni L.M.S., Nandi S.K. Vyas P. and Tamta S. (2002) Somatic embryogenesis in *Quercus floribunda*, an important Central Himalayan oak. In: Role of plant tissue culture in biodiversity conservation and economic development. Eds. Nandi S.K., Palni L.M.S. and Kumar A. Gyanodaya Prakashan, Nainital, pp. 41-52.
16. Sasamoto H, Hosoi Y (1992) Callus proliferation from the protoplasts of embryogenic cells of *Quercus serrata*. Plant Cell Tiss. Org. Cult. 29: 241-245
17. Schenk R.U. and Hildebrandt A.C. (1972) Medium and techniques for induction and growth of monocotyledonous and dicotyledonous plant cell cultures. Can. J. Bot. 50: 199-204
18. Singh JS, Singh SP (1987) Forest vegetation of the Himalaya. Bot. Rev. 53 (1): 80-192
19. Tamta S., Palni L.M.S., Purohit V.K, and Nandi S.K. (2008) *In vitro* propagation of brown oak (*Quercus semecarpifolia* Sm.) from seedling explants (accepted: 21 March 2008 for publication in In Vitro Cell.Dev.Biol.-Plant; 44(2):136-141.
20. Wilhelm E (2000) Somatic embryogenesis in oak (*Quercus* spp.). In Vitro Cell Dev Bio Plant. 36: 349-357

Synthesis, characterization and Electroluminescence of BPh₂(2-(benzimidazol-2-yl) pyridinato) compound

Anchi Yeh

Department of Chemical Engineering,
Chengshiu University, Kaohsiung, Taiwan, R.O.C.

E-mail: acyeh@csu.edu.tw
Phone number: 886-7-7247891
Fax number: 886-7-7247891

ABSTRACT: A novel luminescent boron compound, BPh₂(2-(benzimidazol-2-yl) pyridinato) (**B-BIP**), have been synthesized by reactions of triphenylboron with appropriate ligands, 2-(2-pyridyl)benzimidazole (**BIP**). For the three-layer OLED with the structure ITO/NPB/**B-BIP** /Alq₃/Mg-Ag, an emission band covering the whole visible region from 400 to 650 nm with the maximum brightness of 50 cd/m² was observed, indicating a perfect white light OLED (CIE = 0.32, 0.37). [Journal of American Science 2009: 5(1), 77-82](ISSN: 1545-1003)

Keywords: white light; electroluminescence; imidazole; boron;

1. INTRODUCTION

The chemistry of organoboron compounds have attracted much more attention recently because they are of interest for practical applications [1-3]. Since an organic light emitting diode (OLED) was reported by Tang and Vanslyke [4], LEDs based on organic materials have generated considerable interest and enabled the development of low-cost, full-color, flat-panel displays [5-8]. The best-known EL metal complex used in OLED is Alq₃ which is not only a good emitter but also a highly efficient electron-transporting material, where q is the 8-hydroxyquinolinato ligand [9-12]. Via the modification of the ligands of metal complexes, the emission spectra of devices and other properties, such as thermo stability and carrier mobility, can be tuned. The imidazoles have

been known as good chelating ligands [13] and the attachment of the pyridyl group at 2-position of imidazole would allow the new ligand to form stable compounds with the other atoms. In the present work, the syntheses, structures, and electroluminescent properties of two new boron compounds BPh₂(2-(benzimidazol-2-yl) pyridinato)(**B-BIP**) is reported.

2. EXPERIMENTAL METHOD

The synthesis of the title compound was accomplished by following processes, as shown in Scheme 1. The triphenylboron (1.45g, 6.0 mmole) was slowly added to 100 ml of THF solution containing 2-(2-pyridyl)benzimidazole (2.63g, 13.5 mmole) at 0°C under N₂. After the resulting mixture was stirred at room

temperature for 6 hours, 5 ml isopropyl alcohol was added to quench the reaction. The solvents were removed under vacuum condition at 5×10^{-3} Torr, and the residual solid was sublimed to purify the final product. Light green of **B-BIP** was obtained in 90% yield. The organic light emitting device, Fig. 1, using **B-BIP** as the emitting and electron-transporting layer were fabricated on the transparent conductive indium-tin oxide (ITO) glass substrate. The organic layers and the cathode were sequentially deposited by conventional vacuum vapor deposition in the same chamber without breaking the vacuum under 3×10^{-6} Torr. The cathode composed of magnesium silver alloy (Mg:Ag = 10:1) were deposited onto the top layer of organic materials by co-evaporation of Mg and Ag from different source. Before the deposition, all of the organic materials were purified by the train sublimation method. In the

present work, the

N,N' -bis-(1-naphthyl)- N,N' -diphenyl-1,1'-biphenyl-4,4'-diamine (NPB) was used as the hole-transport material (HTM), and tris(8-quinolinolato) aluminum (Alq_3) was employed as the electron-transporting material (ETM). The EL spectrum and the Commission Internationale de l'Eclairage (CIE) co-ordinates were measured by Pro-650 Spectroscanner (step size is 1.0 nm and bandpass is 4nm), the current-voltage (I-V) characteristic was measured by Keithley 2400 Source meter.

Thermogravimetric analysis (TGA) was performed on a Perkin-Elmer thermogravimeter (Pyris 1) under a dry nitrogen gas flow at the heating rate of $20^\circ\text{C}/\text{min}$. Glass transition temperature (T_g) and melting point (T_m) of materials were determined by differential scanning calorimetry of the Perkin-Elmer differential scanning calorimeter (DSC-7).

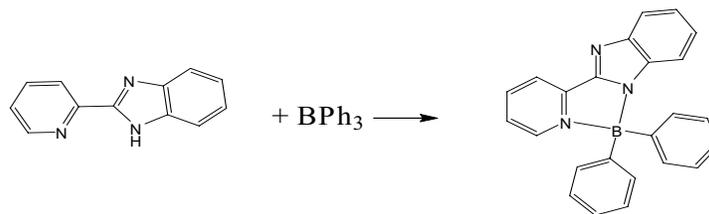

Scheme 1. Synthesis process for the title compound

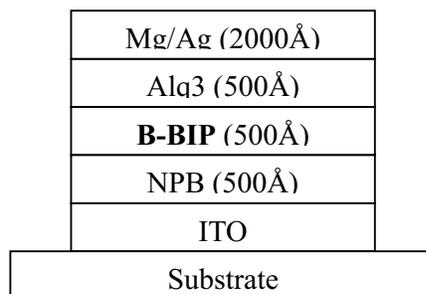

Fig 1: Device structure of organic light emitting device (OLED) fabricated in this work

3. RESULTS AND DISCUSSION

A new boron compound

$\text{BPh}_2(2\text{-}(\text{benzimidazol-2-yl})\text{ pyridinato})$ (**B-BIP**) was prepared by reacting triphenylboron with appropriate imidazole in dry THF (Scheme 1). Both of the compounds are air-stable in the solid state and in solution. The Thermogravimetric analyses (TGA) scans under nitrogen for **B-BIP** powder showed weight loss of 10% at 301 °C, respectively, which reveal that **B-BIP** is quite stable in the atmosphere of nitrogen. The DSC results indicate that the compound **B-BIP** possess a very high melting temperatures, 289°C, respectively, which may serve as an advantage for OLED device fabrication because the materials having high transition temperature could provide the device with greater longevity

[14, 15]. The thin films of **B-BIP** used for the analyses of UV-vis and photoluminescence spectra were obtained by depositing **B-BIP** onto quartz substrates under vacuum condition. At room temperature and low concentration (1×10^{-5} M), the absorption spectral features of **B-BIP** in N,N' -dimethylformamide (DMF) consist of two discrete bands (Fig. 2). The strong absorptions centered at 280 nm for **B-BIP**, respectively, can be assigned to the $\pi\text{-}\pi^*$ transition. The other intense band centered at 348 nm shows a vibrational separation of 1000 cm^{-1} with the $\nu_{0,0}$ transition at $2.94 \times 10^3\text{ cm}^{-1}$. This lower energy band possesses a reasonably high absorptivity ($\epsilon \sim 3 \times 10^4\text{ dm}^3\text{ mol}^{-1}\text{ cm}^{-1}$) and a red shift with increasing polarity of solvent, which is typical for a $\pi\text{-}\pi^*$ transition [16-18].

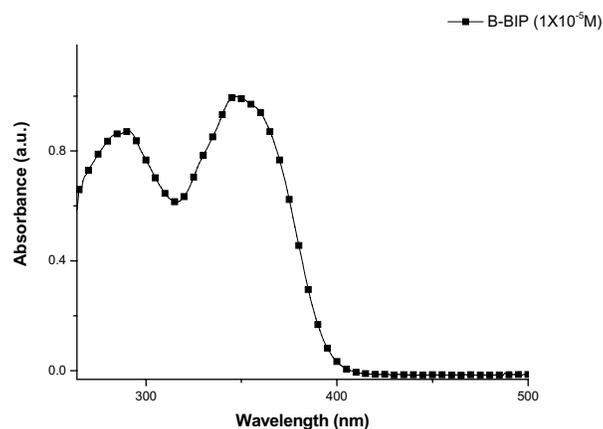

Fig 2: UV-vis spectra of **B-BIP** in N,N' -dimethylformamide

Fig. 3 show the photoluminescence (PL) spectra of the solutions and neat film of **B-BIP** excited with 355 nm laser line. All concentration in DMF, only one emission band was observed with a maximum at 455 nm. Compound **B-BIP** possess the appreciable PL quantum yield, with $\Phi_f = 0.66$ respectively, 10^{-6} M in DMF relative to

3-(2-benzothiazolyl)-7- diethyl-aminocoumarin (C540). To investigate the electroluminescent properties of **B-BIP** typical three-layer device

with the configuration of

ITO/NPB/**B-BIP**/Alq3/MgAg was fabricated by using NPB as the hole-transporting layer and **B-BIP** as the emitter and Alq3 is electron-transporting layer. The EL spectrum of organic light emitting device at the bias voltage of 10 V, Fig. 4, shows the broader emission bands ranging from 400 to 650 nm were observed, indicating that the three-layer LED device emitted white light covering the whole visible light region. The band around 455 nm in

EL spectrum can be attributed to emission of **B-BIP**, because its emission position is almost identical with that in PL spectrum of **B-BIP**. The emission band at 535 is Alq₃ emission position. The emission is almost fixed in the white region in the CIE coordinate of $x = 0.32$ $y = 0.37$. For the small molecular organic materials, to develop the double layer of device with white

emission is very important because this kind of material is very seldom prepared so far, and it is very important for the fabrication of display panels. At the same time important role here may play electron-vibration interactions determining the spectral broadening of the emission lines. So the future strategy of the materials design may be in this way also.

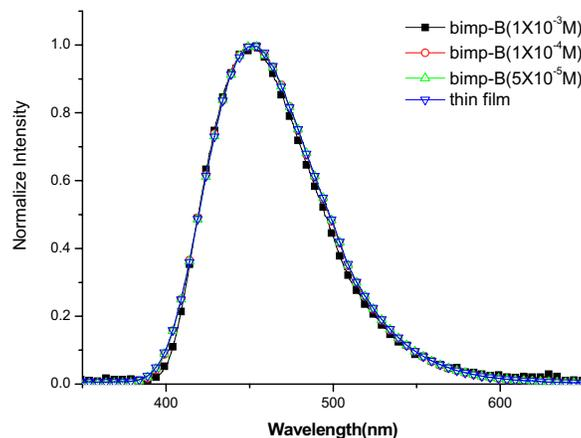

Fig 3: PL spectra of the **B-BIP** in solutions and neat film

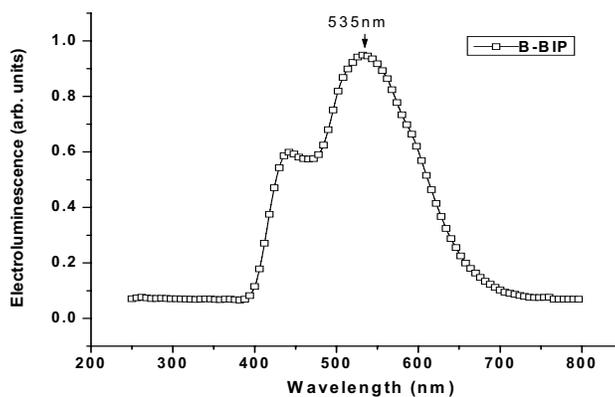

Fig 4: EL spectrum of OLED fabricated in this work.

Figure 5. shows the energy level diagram of the HOMO and LUMO of the different organic materials and the work function of cathode and anode. By using cyclic voltammetry (CV) method obtaining LUMO energy of **B-BIP** is

3.4eV and the optical band gap estimated from the absorption onset, we can determine the HOMO energy at 6.5eV. In Comparison with the energy level of **B-BIP** and NPB, **B-BIP** has much higher hole injection barrier than that of

NPB. As a matter of fact, it is impossible for the hole injection from ITO into **B-BIP** without the assistance of NPB or some HTLs. This diagram pointed out Alq₃ has lower electron injection barrier than that of **B-BIP**. Therefore, the electron injection from the MgAg into **B-BIP** will be enhanced and confines the recombination zone at the interface between NPB and **B-BIP**. Fig.6 shows the current-voltage and luminance-voltage characteristics of this device having a low turn on voltage of about 4.5V for current and luminance. This device shows a brightness of 50 cdm⁻² at the driving voltage of 12V with current density of 390 mA/cm², decaying to 25 cdm⁻² in 100 hours.

4. CONCLUSION

A new compound of emitter for OLED, BPh₂(2-(benzimidazol-2-yl)pyridinato) (**B-BIP**), has been successfully synthesized and investigated. It has been shown that the novel ligands BIP is capable of chelating to B(III) centers and the resulting compounds possess appreciable photoluminescent efficiency and very high thermal stabilities. This study further indicates that the emission band of the devices could be modified by changing the composition of emitting layer and therefore, OLEDs with different colors could be obtained.

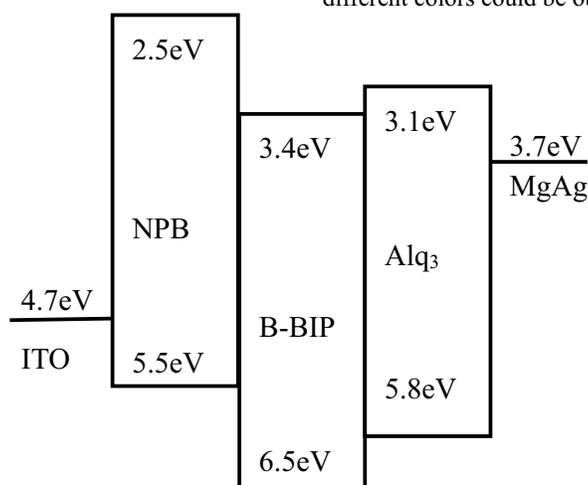

Fig 5: Energy level diagram of OLED materials, ITO, and Mg-Ag alloy

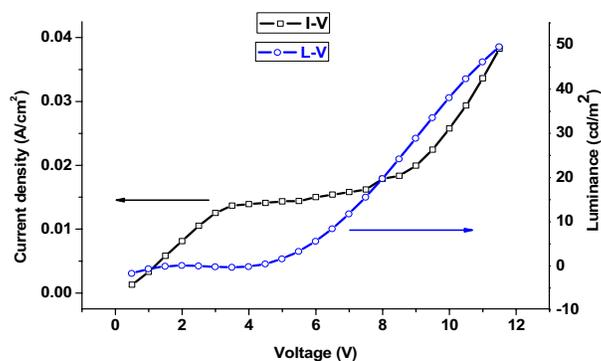

Fig 6: Current-voltage and luminance- voltage characteristics of OLED fabricated in this work

ACKNOWLEDGEMENTS

We wish to thank the National Science Council of the Republic of China for financial support.

REFERENCE

- [1] D. Song, S. F. Liu, R. Y. Wang, S. Wang, *J. Organomet. Chem.* 631 (2001) 175.
- [2] Q. Liu, M. S. Mudadu, H. Schmider, R. Thummel, Y. Tao, S. Wang, *Organometallics* 21 (2002) 4743.
- [3] J. E. Lee, G. C. Choi, B. O. Rim, S. M. Kim, N. G. Park, Y. K. Ha, Y. S. Kim, *Materials Sciencd and Engineering C* 24 (2004) 269.
- [4] C. W. Tang, S.A. VanSlyke, *Appl. Ohys. Lett.*, 51 (1987) 913.
- [5] C. Adachi, S. Tokito, J. Tsutusi, S. Saito, *Jpn. J. Appl. Phys.*, 27 (1988) 713.
- [6] J. H. Burroughes, D. D. C. Bradley, A. R. Brown, R. N. Marks, K. Mackay, R. H. Friend, P. L. Burns, A. B. Homes. *Nature*, 347 (1990) 539.
- [7] J. R. Sheats, H. Antoniadis, M. Hueschen, W. Leonard, J. Miller, R. Moon, D. Roitman, A. Stocking, *Science*, 273 (1996) 884.
- [8] H. Nakada, T. Tohma. *Inorganic and Organic Electroluminescence*, *Wissenschaft-und-Technik-Verlag*, Berlin, (1996) 385.
- [9] S. F. Liu, C. Seward, H. Aziz, N. X. Hu, Z. Popovic, S. Wang, *Organnometallics*, 19 (2000) 5709.
- [10] H. Schmidbaur, J. Lettenbauer, D. L. Wilkinson, G. Muller, O. Z. Kumberger, *Naturforsch*, 46B (1991) 901.
- [11] Anchi Yeh, Shen Cherng, Hsien-Chiao Teng, *The Journal of American Science*, 3 (4) **2007**, 93-94.
- [12] Shen Cherng, Anchi Yeh, Hsien-Chiao Teng, *The Journal of American Science*, 4 (1) **2007**, 95-98.
- [13] R. Balamurugan, M. Palaniandavar, *Inorg. Chem.*, 40 (2001) 2246.
- [14] Z. K. Chen, H. Meng, Y. H. Lai, W. Huang, *Marcromolecules*, 32 (1999) 4351.
- [15] S. Tokito, H. Tanaka, K. Noda, A. Okada, Y. Taga, *Appl. Phys. Lett.*, 70 (1997) 1929.
- [16] Kim, J. H.; Matsuoka, M.; Fukunishi, K, *Dyes and Pigments* 40(1998) 53.
- [17] F. Peral, E. Gallego, *J. Mol. Struct.*, 372 (1995) 101.
- [18] A. Sarkar, S. Chakravorti, *J. Luminescence*, 65 (1995) 163.

Research Article

White Organic Electroluminescence Base on a new Aluminum Complex

¹Anchi Yeh, ²Hsien-Chiao Teng

¹Department of Chemical and materials Engineering,
Chengshiu University, Kaohsiung, Taiwan, R.O.C

²Department of Electrical Engineering

ROC Military Academy, Fengshan, Kaohsiung, Taiwan, R.O.C

E-mail: acyeh@csu.edu.tw ; scteng@nail.cma.edu.tw

ABSTRACT: A bright blue emission material, tris{2-(benzimidazol-2-yl) pyridinato} Aluminum (**AIBIP**) used for white-light of organic light emitting devices has been synthesized. The decomposition temperature was observed at 400 °C and no melting transition (T_m) was observed up to 400°C. For three-layer LED devices with the configuration of ITO/NPB/**AIBIP** /Alq3/MgAg, the white light emission covering the whole visible region from 400 to 700 nm with the maximum brightness of 75 cd/m² and current density of 330 mA/cm² was observed. [Journal of American Science 2009: 5(1), 83-87] (ISSN: 1545-1003)

Keywords: Electroluminescence; white light; device

1. INTRODUCTION

White organic light emitting diodes have attracted much attention, because their potential applications in the backlights of laptop computers and portable panel light sources. In the literatures, several strategies including multi-layer devices have been developed to realize highly efficient white organic electroluminescence [1-5]. Luminescent chelate complexes have been shown to be particularly useful in electroluminescent (EL) displays because of their relatively high stability and volatility. The most well-known example of such chelate compounds is Alq₃, not only a good emitter but also a highly efficient electron-transporting material, where q is the 8-hydroxyquinolinato ligand [6, 7]. Via the modification of the ligand of metal chelate compound, the emission color of a metal chelate compound may be tuned. Other properties, such as thermal stability and carrier mobility, may also be improved upon. In the present work, we report the synthesis and electroluminescent (EL) property of tris{2-(benzimidazol-2-yl) pyridinato} Aluminum (**AIBIP**). The **AIBIP** containing N,N-bidentate ligand instead of N,O-bidentate

one such as 8-hydroxyquinoline. Therefore, the thermal stability, an important character for the practical application in the electronic fields, of this metal complex is investigated by thermogravimetric analysis (TGA) and differential scanning calorimetry (DSC). The organic emitting device using **AIBIP** as emitting layer has been fabricated to study the electroluminescent property of this metal complex.

2. EXPERIMENTAL METHOD

The synthesis of the title compound was accomplished by following processes, as shown in Scheme 1. The triethylaluminum solution (25% w/w in hexane 1.86ml, 2.82×10^{-3} mole) was slowly added to 100 ml of THF solution containing 2-(2-pyridyl)benzimidazole (1.75g, 9.0×10^{-3} mole) at 0°C under N₂. After the resulting mixture was stirred at room temperature for 6 hours, 5 ml isopropyl alcohol was added to quench the reaction. The solvents were removed under vacuum condition at 5×10^{-3} Torr, and the residual solid was sublimed to purify the final product. Light green of **AIBIP** was obtained in 85% yield. The formula of this compound has been determined by ¹H NMR and

elemental analysis. The organic light emitting device, Fig. 1, using **AIBIP** as the emitting and electron-transporting layer were fabricated on the transparent conductive indium-tin oxide (ITO) glass substrate. The organic layers and the cathode were sequentially deposited by conventional vacuum vapor deposition in the same chamber without breaking the vacuum under 3×10^{-6} Torr. The cathode composed of magnesium silver alloy (Mg:Ag = 10:1) were deposited onto the top layer of organic materials by co-evaporation of Mg and Ag from different source. Before the deposition, all of the organic materials were purified by the train sublimation method. In the present work, the N,N'-bis-(1-naphthyl)-N,N'-diphenyl-1,1'-biphenyl-4,4'-diamine (NPB) was used as the

hole-transport material (HTM), and tris (8-quinolinolato) aluminum (Alq_3) was employed as the electron-transporting material (ETM). The EL spectrum and the Commission Internationale de l'Eclairage (CIE) co-ordinates were measured by Pro-650 Spectroscanner (step size is 1.0 nm and bandpass is 4nm), the current-voltage (I-V) characteristic was measured by Keithley 2400 Source meter.

Thermogravimetric analysis (TGA) was performed on a Perkin-Elmer thermogravimeter (Pyris 1) under a dry nitrogen gas flow at the heating rate of 20°C/min. Glass transition temperature (T_g) and melting point (T_m) of materials were determined by differential scanning calorimetry of the Perkin-Elmer differential scanning calorimeter (DSC-7).

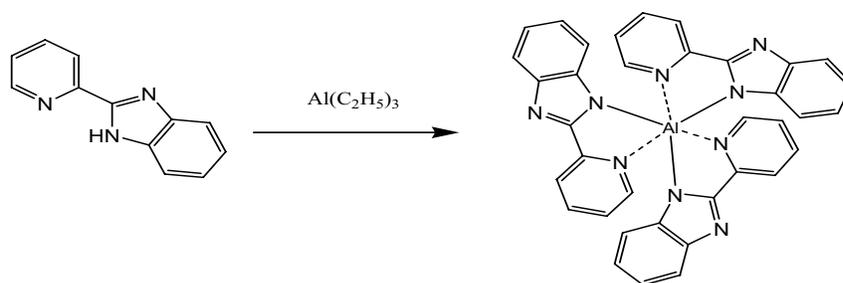

Scheme 1. Synthesis process for the **AIBIP** complex.

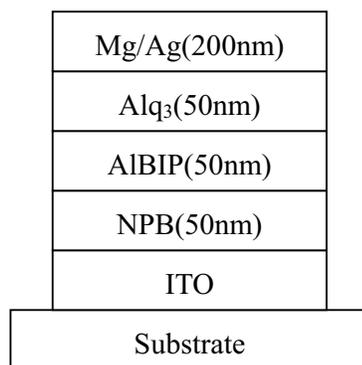

Fig 1: The organic light emitting device (OLED).

3. RESULTS AND DISCUSSION

The TGA of **AIBIP** that possesses a maximum rate of weight loss occurring at 400 °C and no weight loss was observed at the temperature lower than 350 °C. Above 600 °C, there is about 14 wt % of residue composed of aluminum ash. This aluminum complex is reasonably stable upon exposure to air and exhibited a high thermal stability in nitrogen. The melting temperature (T_m) of **AIBIP** was not observed up to 400 °C with DSC curve. The DSC and TGA results indicate that the **AIBIP** possesses a high thermal stability, which may serve as an advantage for the fabrication of organic light emitting device because the use of the materials with high thermal stability as the active emissive layer or carrier transporting layer may provide the device with greater longevity [11, 12].

The Photoluminescent (PL) spectra of the **AIBIP** solutions and neat film, excited with 350 nm laser line, were illustrated in Figure 2. At low concentration, 1×10^{-5} M in DMF, only one emission band is observed with maximum at 450 nm, corresponding to the relaxation of **AIBIP** from the excited state of a single molecule into ground state. There is red shift emission band that a maximum at 460 nm is

observed in the spectrum of the **AIBIP** neat film. To investigate the electroluminescent properties of **AIBIP** typical three-layer device with the configuration of ITO/NPB/**AIBIP**/Alq3/MgAg was fabricated by using NPB as the hole-transporting layer and **AIBIP** as the emitter and Alq3 is electron-transporting layer. The EL spectrum of organic light emitting device at the bias voltage of 10 V, Fig. 3, shows the broader emission bands ranging from 400 to 700 nm were observed, indicating that the three-layer LED device emitted white light covering the whole visible light region. The band around 465 nm in EL spectrum can be attributed to emission of **AIBIP**, because its emission position is almost identical with that in PL spectrum of **AIBIP**. The emission band at 525 nm is Alq3 emission position and 565 nm can be attributed to the exciplex emission originated from the interface between NPB and **AIBIP**. The emission is almost fixed in the white region in the CIE coordinate of $x = 0.32$ $y = 0.37$. For the small molecular organic materials, to develop the double layer of device with white emission is very important because this kind of material is very seldom prepared so far, and it is very important for the fabrication of display panels.

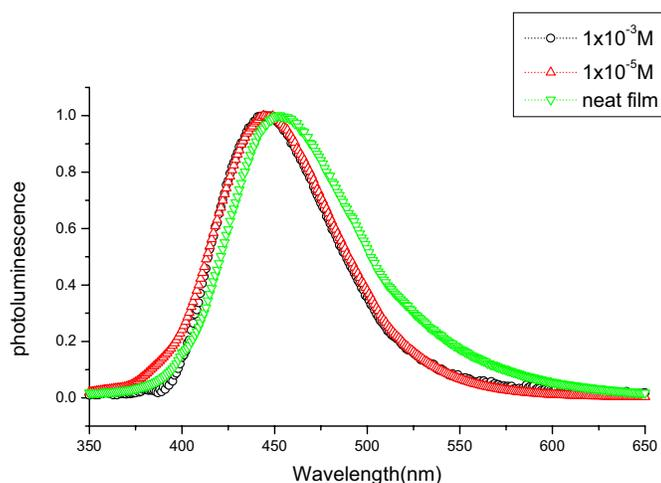

Fig 2: Photoluminescent spectra of the **AIBIP** in solutions and neat film

The change of the spectral wavelength may be achieved also by general conception of search and design of modified materials for wide band emission consists in substitution of the backside groups by electron acceptors like halogens etc. and different kind of donors [13,

14]. At the same time important role here may play electron-vibration interactions determining the spectral broadening of the emission lines. So the future strategy of the materials design may be in this way also.

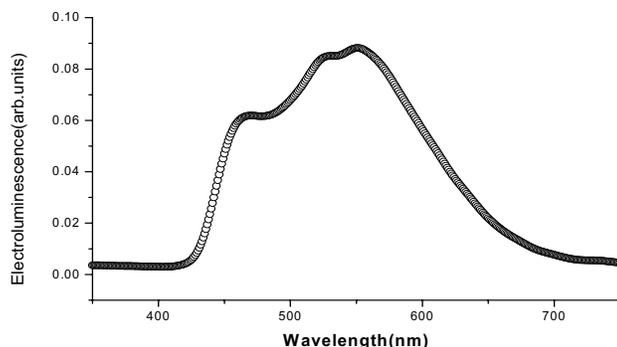

Fig 3: EL spectrum of OLED fabricated in this work.

Figure 4 shows the energy level diagram of the HOMO and LUMO of the different organic materials and the work function of cathode and anode. By using cyclic voltammetry (CV) method obtaining LUMO energy of **AIBIP** is 2.8eV and the optical band gap estimated from the absorption onset, we can determine the HOMO energy at 5.6eV. In Comparison with the energy level of **AIBIP** and NPB, **AIBIP** has much higher hole injection barrier than that of NPB. As a matter of fact, it is impossible for the hole injection from ITO into **AIBIP** without the assistance of NPB or some HTLs. This

diagram pointed out Alq_3 has lower electron injection barrier than that of **AIBIP**. Therefore, the electron injection from the MgAg into **AIBIP** will be enhanced and confines the recombination zone at the interface between NPB and **AIBIP**. Fig.5 shows the current-voltage and luminance-voltage characteristics of this device having a low turn on voltage of about 4.0V for current and luminance. This device shows a brightness of 75 cdm^{-2} at the driving voltage of 16V with current density of 330 mA/cm^2 , decaying to 30 cdm^{-2} in 120 hours.

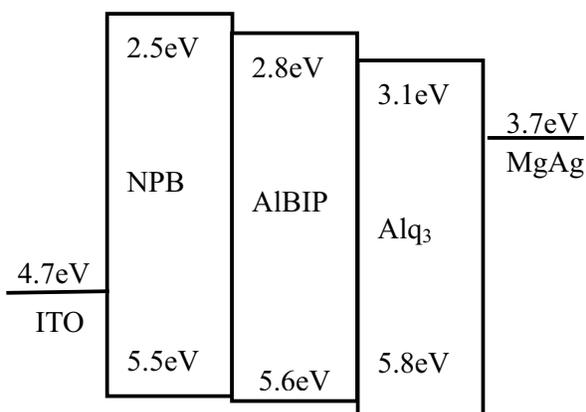

Fig 4: Energy level diagram of OLED materials, ITO, and Mg-Ag alloy

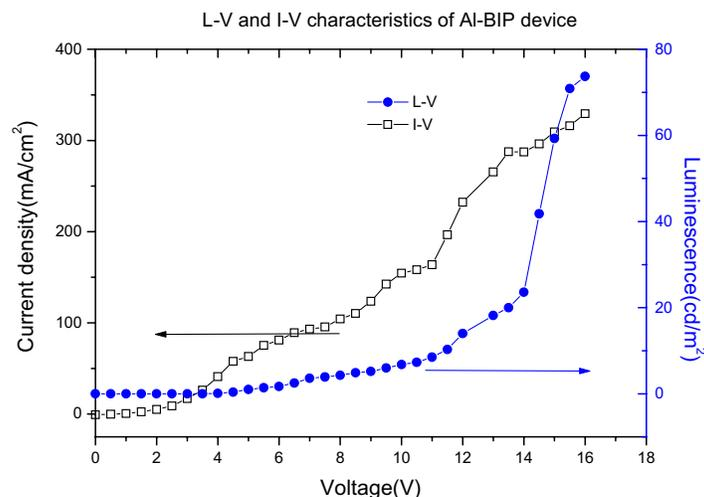

Fig 5: Current-voltage and luminance- voltage characteristics of OLED fabricated in this work.

4. CONCLUSION

A novel bright blue emission material, tris{2-(benzimidazol-2-yl) pyridinato} Aluminum (AIBIP), was successfully prepared by the reaction of 2-(2-pyridyl)benzimidazole and triethylaluminum. Because of its high thermal stability and excellent electrical characteristics, AIBIP and its related compound suggest a possible application for the use of white-light of the organic light emitting devices.

Acknowledgements

This research was supported by the National Science Council of the Republic of China (Grant No. NSC94 2113-M-230-001)

Corresponding Authors:

Anchi Yeh

Hsien-Chiao Teng

E-mail: acyeh@csu.edu.tw

E-mail: scteng@nail.cma.edu.tw

Reference:

- [1] C. W. Tang, S.A. VanSlyke, Appl. Ohys. Lett., 51 (1987) 913.
- [2] C. Adachi, S. Tokito, J. Tsutusi, S. Saito, Jpn. J. Appl. Phys., 27 (1988) 713.
- [3] J. H. Burroughes, D. D. C. Bradley, A. R. Brown, R. N. Marks, K. Mackay, R. H. Friend, P. L. Burns, A. B. Homes. Nature, 347 (1990) 539.
- [4] J. R. Sheats, H. Antoniadis, M. Hueschen, W. Leonard, J. Miller, R. Moon, D. Roitman, A. Stocking, Science, 273 (1996) 884.
- [5] H. Nakada, T. Tohma. Inorganic and Organic Electroluminescence, Wissenschaft-und-Technik-Verlag, Berlin, (1996) 385.
- [6] S. -F. Liu, C. Seward, H. Aziz, N. -X. Hu, Z. Popovic, S. Wang, Organnometallics, 19 (2000) 5709.
- [7] H. Schmidbaur, J. Lettenbauer, D. L. Wilkinson, G. Muller, O. Z. Kumberger, Naturforsch, 46B (1991) 901.
- [8] T. R. Chen, A. C. Yeh and J. D. Chen, Tetrahedron Lett., 46 (2005) 1569.
- [9] S. -F. Liu, Q. Wu, H. L. Schmider, H. Aziz, N. -X. Hu, Z. Popovic, S. Wang, J. Am. Chem. Soc., 122 (2000) 3672.
- [10] Q. Wu, M. Esteghamatian, N. -X. Hu, Z. D. Popovic, G. Enright, S. R. Breeze, S. Wang, Angew. Chem. Int. Ed., 38 (1999).
- [11] Z. -K. Chen, H. Meng, Y. -H. Lai, W. Huang, Macromolecules, 32 (1999) 4351.
- [12] S. Tokito, H. Tanaka, K. Noda, A. Okada, Y. Taga, Appl. Phys. Lett., 70 (1997) 1929.
- [13] M. Makowska-Janusik, J. Sanetra, H. Palmers, D. Bogdal, E. Gondek, I. V. Kityk, Materials Letters, 58 (2004) 555.
- [14] Albert J. van Reenen, Lon J. Mathias, Liezel Coetzee, Polymer 45 (2004) 79

Journal of American Science

ISSN: 1545-1003

January 10, 2009

The international academic journal, "*The Journal of American Science*" (ISSN: 1545-1003), is registered in the United States, and invites you to publish your papers.

Any valuable papers that describe natural phenomena and existence or any reports that convey scientific research and pursuit are welcome, including both natural and social sciences. Papers submitted could be reviews, objective descriptions, research reports, opinions/debates, news, letters, and other types of writings that are nature and science related.

This journal will be no charge for the manuscript contributors. If the author needs hard copy of the journal, it will be charged for US\$60/issue to cover the printing and mailing fee. Here is a new avenue to publish your outstanding reports and ideas. Please also help spread this to your colleagues and friends and invite them to contribute papers to the journal. Let's work together to disseminate our research results and our opinions.

Papers in all fields are welcome, including articles of natural science and social science.

**Please send your manuscript to editor@americanscience.org;
americansciencej@gmail.com**

**For more information, please visit <http://www.americanscience.org>;
<http://www.sciencepub.org>**

Marsland Press
2158 Butternut Drive
Okemos, MI 48864
The United States
Telephone: (517) 349-2362
**Email: editor@americanscience.org
americansciencej@gmail.com**
**Website: <http://www.americanscience.org>
<http://www.sciencepub.org>**

The Journal of American Science

ISSN 1545-1003

Marsland Press
2158 Butternut Drive
Okemos, Michigan 48864
The United States
Telephone: (517) 349-2362

Emails: editor@americanscience.org;
americansciencej@gmail.com;
sciencepub@gmail.com

Websites: <http://www.americanscience.org>;
<http://www.sciencepub.net>;
<http://www.sciencepub.org>

ISSN 1545-1003

