

An Overview of Synthetic Aperture Radar and Its Applications

Pavan Kumar^{1,*}, Meenu Rani², Poonam Bisht³, Manoj Yadav⁴, M. P. Sharma⁵, R. Prawasi⁶ and R. S. Hooda⁷

J.R.F.^{1,2}, Student³, Assistant Scientist^{4,5}, Senior Scientific Assistant⁶, Chief Scientist⁷
^{1,2,4,5,6,7}Haryana Space Applications Centre (HARSAC)

(Department of Science & Technology), Hisar, Haryana, India

³Kumaun University, NRDMS, S.S.J. Campus, Almora, Utrakhand, India

*Correspondence author- Email: pawan2607@gmx.com

Abstract: A Synthetic Aperture Radar is an antenna which collects and stores all signals with respect to amplitude, phase, frequency, polarization and running time for gaining desired information with Special processing algorithms. This paper provides a review of the progress in regard to the InSAR remote sensing technique and its applications in earth and environmental sciences, especially in the past decade. Synthetic Aperture Radar (SAR) is a form of radar whose defining characteristic is its use of relative motion between an antenna and its target region to provide distinctive long-term coherent-signal variations that are exploited to obtain finer spatial resolution than is possible with conventional beam-scanning means. It originated as an advanced form of side-looking airborne radar (SLAR). Recent (2010) airborne systems provide resolutions to about 10 cm, ultra-wide band systems provide resolutions of a few millimeters, and experimental terahertz SAR has provided sub-millimeter resolution in the laboratory. SAR images have wide applications in remote sensing and mapping of the surfaces of both the Earth and other planets. SAR can also be implemented as "inverse SAR" by observing a moving target over a substantial time with a stationary antenna. An antenna for airborne synthetic aperture radar (SAR) has been developed in Multimedia University. It is a C-band, probe-fed micro strip patch antenna with an operating frequency of 6 GHz and a bandwidth of 168 MHz (SWR<1.5).

[Pavan Kumar, Meenu Rani, Poonam Bisht, Manoj Yadav, M. P. Sharma, R. Prawasi and R. S. Hooda. **An Overview of Synthetic Aperture Radar and Its Applications.** New York Science Journal 2011; 4(6):6-10]. (ISSN: 1554-0200). <http://www.sciencepub.net/newyork>.

Keyword: SAR, SLAR, Antenna

1. Introduction

Remote Sensing is the science of gathering data and information about features, objects and classes on the Earth's land surface, oceans and atmosphere from sensors located beyond the immediate vicinity of such source. One such sensor that has captured the interest of the scientific community is the Synthetic Aperture Radar (SAR). The SAR can be achieved by mounting the antenna on the back side of the mobile terminal or profiling the handset (Amos *et al.*, 1990) Planar Inverted F-Antenna (PIFA) has attracted many researchers to reduce SAR due to low profile, simple structure, reasonable antenna performance and half-space radiation characteristics (Lazzi *et al.*, 1998; Park, 2003). There are a lot of modifications performed to the PIFA to reduce radiation towards human body. The arm width, patch shape, and the feed and shorting pin position can be modified and optimized to maximize the SAR reduction. Some structures can also be attached to reduce the SAR. In 2006, (Chan & Vetharatnam, 2000) tried to investigate the effect of sidewall attachment of internal patch antenna ground plane on SAR (Chan *et al.*, 2006).

It is capable of producing high-resolution imagery in microwave bands by using a special processing technique that synthesises a very long antenna aperture,

thus the name synthetic aperture. Microwave frequencies are preferred as it can penetrate clouds; certain wavelength can even penetrate forest canopy. The design of antennas for Synthetic Aperture Radars has received a great deal of attention in the literature on the subject. Most antennas for space borne SARs are rather large in size, with a range of 9 to 15 meters being fairly typical for the antenna and length (azimuth dimension), and somewhere between 10 and 20 times the wavelength for the antenna height (elevation dimension). Since space borne SARs flown to data has had wavelengths in the range 3 cm to 24 cm, this means that the antenna heights are fairly significant. Space borne SAR antennas are thus some of the largest size structures flown in space. The radar group at the Goodyear research facility in Litchfield, Arizona is credited with building the first airborne SAR, back in 1953. It operated at 930MHz using a Yagi antenna with a very wide beam width (1000). Subsequently many more airborne SAR systems was developed, notable among them are the AIRSAR by Jet Propulsion Laboratory (JPL), E-SAR by German Aerospace Research Establishment (DLR), C/XSAR by Canadian Centre for Remote Sensing (CCRS) and EMISAR by Danish Centre for Remote Sensing (DCRS). These airborne SAR systems employed many types of

antennas, ranging from Yagi, slotted-waveguide to microstrip. However, modern civilian SAR system generally operates in L, C and X-band, where microstrip antenna dominates.

In June 1998, Centre for Applied Electromagnetic, Multimedia University (MMU), Malaysia, collaboration with Malaysian Centre for Remote Sensing (MACRES), initiated a program to build Malaysia's first indigenously built airborne Synthetic Aperture Radar (SAR). It is a C-band (6GHz) single vertically polarised, linear FM radar system (Chan & Vetharatnam, 2000). Some selected specification of the SAR system is listed in Table 1. A microstrip patch antenna is constructed for the above SAR sensor taking into account all the parameters and constraints of an airborne platform.

Table 1. SAR specifications

Mode of operation	Strip map
Altitude	7.5 km
Incident angle	500
Swath width	8km
Azimuth beam width	30
Elevation beam width	240
Platform speed	100m/s
Pulse repetition frequency	1000Hz nominal

2. How Does Radar Work?

RADAR = Radio Detection and Ranging. Since radar pulses propagate at the speed of light, the difference to the "target" is proportional to the time it takes between the transmit event and reception of the radar echo.

Figure 1. General structure of a SAR system

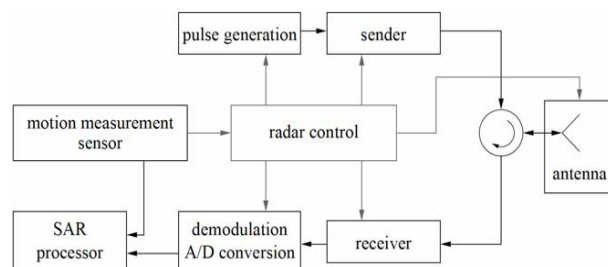

2.1 SAR Methods of data processing

Interferometry (InSAR/IfSAR)-Superimpose two or more waves, in order to detect the differences Space born applications:

- ❖ Dual-pass (or Repeat-pass) interferometry
- ❖ Differential interferometry displacements with sub-cm accuracy

Single-pass interferometry, using a platform with two SAR antennas Across track (perpendicular to flight direction) or Along track (parallel). It is useful for topographic mapping, Digital Terrain Model (DTM) generation, velocity mapping (currents mapping, detection of moving targets), change mapping (earthquake monitoring, landslides, glacier dynamics).

InSAR is an emerging technology and is not comparable to any conventional technique of deformation measurement. Although becoming more accepted, it has to date been used in a very limited number of operational applications. InSAR applicability is hampered by changes in the complex reflection coefficient of the ground being monitored (for example, from vegetation growth or variation in moisture content) resulting in a de-correlation of the interferometric image pair. With few exceptions, differential interferometry for surface motion has only been successful in regions where ground conditions change little over several weeks, such as very arid locations and glaciers

3. Elevation Displacement

Elevation displacement, also referred to as geometric distortion, is the image displacement in a remote sensing image toward the nadir point in radar imagery due to sensor/target imaging geometries. In a radar image the displacement is toward the sensor and can become quite large when the sensor is nearly overhead. The displacement increases with decreasing incidence angle. The four characteristics resulting from the geometric relationship between the sensor and the terrain that are unique to radar imagery are foreshortening, pseudo-shadowing, layover and shadowing. Topographic features like mountains, as well as artificial targets like tall buildings, will be displaced from their desired orthographic position in an image. The effect may be used to create stereo images. It may be removed from an image through independent knowledge of the terrain profile

3.1 All Weather Imaging

Due to the cloud penetrating property of microwave, SAR is able to acquire "cloud-free" images in all weather and its data is known as all weather data. This is especially useful in the tropical regions which are frequently under cloud covers throughout the year. Being an active remote sensing device, it is also capable of night time operation. It is also quite useful to monitor the earth resources and damages after natural calamities and disasters such as tsunami, hail storm, flood etc. when all the communication and transport network are failed.

3.2 Antenna Characteristics

A second type of system, Synthetic Aperture Radar (SAR), is exclusive to moving platforms, such as aircrafts and satellites. An important characteristic of a SAR image is its resolution, which is defined in terms of minimum distance at which two closely spaced scatterers of equal strength may be resolved. SAR and conventional radar achieve slant range resolution in a similar way by using pulse-ranging technique. It uses an antenna of much smaller physical dimensions, which sends its pulses from different positions as the platform advances, simulating a real aperture by integrating the pulse echos into a composite signal. It is possible through appropriate processing to simulate effective antenna lengths up to 100 m or more. This system depends on the Doppler Effect (apparent frequency shift due to the target's or the radar-vehicle's velocity) to determine azimuthal resolution. As coherent pulses transmitted from the radar source reflect from the ground to the advancing platform (aircraft or spacecraft), the target acts as if it were in apparent (relative) motion. This motion results in changing frequencies, which give rise to variations in phase and amplitude in the returned pulses. The radar records these data for later processing by digital correlation methods.

3.3 Antenna Gain

Independent of the use of a given antenna for transmitting or receiving, an important characteristic of this antenna is the gain. Some antennas are highly directional; that is, more energy is propagated in certain directions than in others. The ratio between the amount of energy propagated in these directions compared to the energy that would be propagated if the antenna were not directional (Isotropic Radiation) is known as its gain. When a transmitting antenna with a certain gain is used as a receiving antenna, it will also have the same gain for receiving.

3.4 Antenna Pattern

Most radiators emit (radiate) stronger radiation in one direction than in another. A radiator such as this is referred to as anisotropic. However, a standard method allows the positions around a source to be marked so that one radiation pattern can easily be compared with another.

The energy radiated from an antenna forms a field having a definite radiation pattern. A radiation pattern is a way of plotting the radiated energy from an antenna. This energy is measured at various angles at a constant distance from the antenna. The shape of this pattern depends on the type of antenna used.

To plot this pattern, two different types of graphs, rectangular-and polar-coordinate graphs are used. The polar-coordinated graph has proved to be of great use in

studying radiation patterns. In the polar-coordinate graph, points are located by projection along a rotating axis (radius) to an intersection with one of several concentric, equally-spaced circles. The main beam (or main lobe) is the region around the direction of maximum radiation (usually the region that is within 3 dB of the peak of the main beam). The main beam in Figure 1 is north bound.

The side lobes are smaller beams that are away from the main beam. These side lobes are usually radiation in undesired directions which can never be completely eliminated. The side lobe level (or side lobe ratio) is an important parameter used to characterize radiation patterns. It is the maximum value of the side lobes away from the main beam and is expressed in Decibels. One side lobe is called back lobe. This is the portion of radiation pattern that is directed opposing the main beam direction.

The now following graph shows the rectangular-coordinated graph for the same source. In the rectangular coordinate graph, points are located by projection from a pair of stationary, perpendicular axes. The horizontal axis on the rectangular-coordinate graph corresponds to the circles on the polar coordinate graph. The vertical axis on the rectangular-coordinate graph corresponds to the rotating axis (radius) on the polar coordinate graph. The measurement scales in the graphs can have linear as well as logarithmic steps.

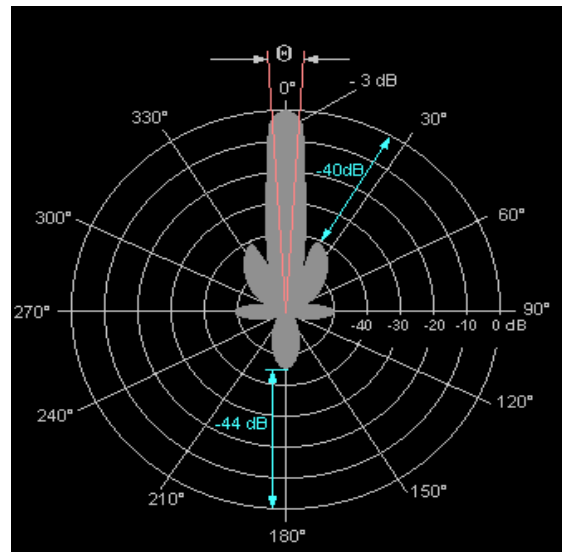

Figure 2. Antenna pattern in a polar-coordinate

3.5 Beam Width

The angular range of the antenna pattern in which at least half of the maximum power is still emitted is described as a "Beam Width". Bordering points of this major lobe are therefore the points at which the field strength has fallen in the room around 3 dB regarding the maximum field strength. This angle is then

described as beam width or aperture angle or half power (- 3 dB) angle - with notation Θ (also ϕ). The beam width Θ is exactly the angle between the 2 red marked directions in the upper pictures. The angle Θ can be determined in the horizontal plane (with notation Θ_{AZ}) as well as in the vertical plane (with notation Θ_{EL}).

3.6 Major and Side Lobes (Minor Lobes)

The pattern shown in the upper figures has radiation concentrated in several lobes. The radiation intensity in one lobe is considerably stronger than in the other. The strongest lobe is called major lobe; the others are (minor) side lobes. Since the complex radiation patterns associated with arrays frequently contain several lobes of varying intensity, you should learn to use appropriate terminology.

3.7 Front-to-Back Ratio

The front-to-back ratio of an antenna is the proportion of energy radiated in the principal direction of radiation to the energy radiated in the opposite direction. A high front-to-back ratio is desirable because this means that a minimum amount of energy is radiated in the undesired direction.

3.8. Aperture

The effective aperture of an antenna A_e is the area presented to the radiated or received signal. It is a key parameter, which governs the performance of the antenna. The gain is related to the effective area by the following relationship:

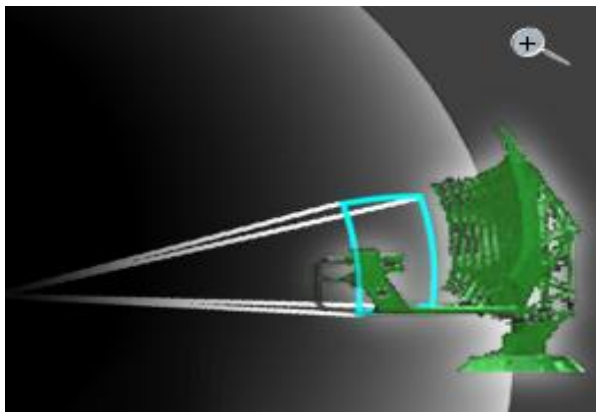

Figure 3. Spherical Surface Antenna Aperture

$$G = \frac{4\pi \cdot A_e}{\lambda^2}; A_e = K_a \cdot A$$

Where:

- λ =Wave length
- A_e =Effective antenna aperture
- A =Physical area of the antenna
- K_a =Antenna aperture efficiency

The aperture efficiency depends on the distribution of the illumination across the aperture. If this is linear then $K_a = 1$. This high efficiency is offset by the relatively high level of sidelobes obtained with linear illumination. Therefore, antennas with more practical levels of sidelobes have an antenna aperture efficiency less than one ($A_e < A$).

4. Applications

Applications of SAR can be very broad in ice sheet motion, seismology, land surface deformation due to earthquakes, land subsidence due to excess water pumping or uplift due to ground water recharge, volcanoes and landslide movement, glacier flow, postglacial rebound of the lithosphere and forest canopy height etc.

4.1 Volcanology

Volcanic processes such as magma accumulation in subsurface reservoirs, magma transport and emplacement beneath volcanic structures will result in surface deformation, which InSAR can be used to detect. GPS is one of the most suitable techniques to measure ground surface deformations because of high accuracy and provision of three dimensional components of deformation field. But the limitation of GPS station density (GPS stations per unit area) and the continuous coverage of interferogram make the integration of InSAR and GPS a useful approach to map highly accurate deformations (i.e. at sub centimeter levels) with unprecedented spatial coverage.

4.2 Land Subsidence and Uplift

Land subsidence can be caused by groundwater pumping, which results in compaction of aquitards during the slow process of aquitards drainage. SAR application will continue to be very useful in monitoring the land subsidence due to excessive withdrawal in the next decades. Conversely, during a wet season, ground water recharge makes the ground-water levels to rise.

4.3 Glaciology

Continuous retreat of glaciers and disintegration of ice shelves cause concerns of rise of sea level and severe weather due to changes of climate patterns (Nerem *et al.*, 2006). For monitoring of mountain glaciers (Li *et al.*, 2008; Berthier *et al.*, 2005), icefalls or marginal shear zones of glaciers, crop growth (Blaes *et al.*, 2003), short periods of time (1-3 days) of successive SAR images are required. Due to the displacement gradient (i.e. strain) threshold of InSAR, only a limited number of studies (Rabus and Fatland, 2006; Strozzi *et al.*, 2002; Wangenstein, 2005) have successfully measured the ice-flow velocity field with InSAR.

4.4 Forestry

In forestry, canopy height is often used to estimate forest biomass and above-ground forest carbon stock as the quantities are allometrically related. Because the phase of a pixel is the sum of the returns from a collection of scatterers including stems, branches, twigs, leaves or needles, trunks, and surface soil, the types of scatterers interact most strongly with the radar wave depend on the wavelength, polarization, incidence angle, and vegetation sub-pixel fraction. including polarimetric interferometry (PolInSAR) (Cloude, 1998), because the interferometric phase relates to terrain height and vegetation canopy height (Balzter, H., 2001; Balzter *et al.*, 2007; Lee *et al.*, 2003; Patenaude *et al.*, 2005). Forest canopy height can be estimated using InSAR.

Acknowledgements

We are thankful to HARSAC, Hisar, Haryana, India for providing necessary support. We are grateful to Dr. R. S. Hooda and Dr. Manoj Yadav for their guidance and valuable suggestions to prepare this manuscript.

Correspondence to:

Pavan Kumar

Junior Research Fellow

Haryana Space Applications Centre (HARSAC)

CCS HAU Campus, Hisar, Haryana, India

☎ +91-9416317168

References

- [1] Amos SV. *et al.* "Modelling of Handset Antenna Interactions with the User and SAR Reduction Techniques". National Conference on Antennas and Propagation. 1990; Conference Publication No. 461.
- [2] Balzter H. Forest mapping and monitoring with interferometric synthetic aperture radar (InSAR). *Prog. Phys. Geog.* 2001; 25: 159-177.
- [3] Balzter H, Rowland, CS, Saich P. Forest canopy height and carbon estimation at Monks Wood National Nature Reserve, UK, using dual-wavelength SAR interferometry. *Remote Sens. Environ.* 2007; 108: 224-239.
- [4] Berthier E, Vadon H, Baratoux D, Arnaud Y, Vincent C, Feigl KL, Rémy F, Legrésy B. Surface motion of mountain glaciers derived from satellite optical imagery. *Remote Sens. Environ.* 2005; 95: 14-28.
- [5] Blaes X, Defourny P. Retrieving crop parameters based on tandem ERS 1/2 interferometric coherence images. *Remote Sens. Environ.* 2003; 88: 374-385.
- [6] Chan KH. *et al.* "Effect of internal patch antenna ground plane on SAR", 17th International Zurich Symposium on Electromagnetic Compatibility. 2006; pp. 513-516.
- [7] Chan YK & Vetharatnam G. Imaging radar system and antenna design. First National Microwave Remote Sensing Seminar. 2000.
- [8] Cloude SR and Papathanassiou KP. Polarimetric SAR interferometry. *IEEE Trans. Geosci. Remote Sens.* 1998; 36: 1551-1565.
- [9] Lazzi G. *et al.* "Experimental study on compact, high-gain, low SAR single- and dual-band patch antenna for cellular telephones", Antennas and Propagation Society International Symposium. 1998; Volume 1: pp. 130-133.
- [10] Lee JS, Cloude SR, Papathanassiou KP, Grunes MR, and Woodhouse IH. Speckle filtering and coherence estimation of polarimetric SAR interferometry data for forest applications. *IEEE Trans. Geosci. Remote Sens.* 2003. 41: 2254-2263.
- [11] Li S, Benson C, Gens R, and Lingle C. Motion patterns of Nabesna Glacier (Alaska) revealed by interferometric SAR techniques. *Remote Sens. Environ.* 2008; 112: 3628-3638.
- [12] Nerem RS, Leuliette É and Cazenave A. Present-day sea-level change: a review. *C. R. Geoscience* 2006; 338: 1077-1083.
- [13] Park JD. "A low SAR design of folder type handset with dual antennas", Antennas and Propagation Society International Symposium. 2003; Volume 2: pp. 1005-1008.
- [14] Patenaude G, Milne R, and Dawson TP. Synthesis of remote sensing approaches for forest carbon estimation: reporting to the Kyoto Protocol. *Environ. Sci. Policy* 2005; 8: 161-178.
- [15] Rabus RT, and Fatland DR. Comparison of SAR-interferometric and surveyed velocities on a mountain glacier: Black Rapids Glacier, Alaska, U.S.A. *J. Glaciol.* 2000; 46: 119-128.
- [16] Strozzi T, Luckman A, Murray T, Wegmüller U and Werner C. Glacier motion estimation using SAR offset-tracking procedures. *IEEE Trans. Geosci. Remote Sens.* 2002; 40: 2384-2391.
- [17] Wangensteen B, Weydahl DJ, Hagen JO. Mapping glacier velocities on Svalbard using ERS tandem DInSAR data. *Norsk Geografisk Tidsskrift-Norwegian. J. Geog.* 2005; 59: 276-285.