

Growth as a Prerequisite for Sustainability

P.C. van den Noort

Em Prof. Wageningen University, noort1935@hotmail.com

Abstract: A highly developed economy cannot adopt a zero growth situation. According to chaos theory, in such a developed economy there must be a continuous process of inventions and innovations in order to prevent a collapse of the existing socioeconomic structure.

[P.C. van den Noort. Growth as a Prerequisite for Sustainability. New York Science Journal 2011;4(12):38-42]. (ISSN: 1554-0200). <http://www.sciencepub.net/newyork>.

Keywords: economy, zero-growth, chaos, logistic evolution, innovation, instability, inventions, vitality, revolution

1. A Biological Analogy

In economics we are used to biological oriented concepts, e.g., the growth of population, of production and of national income. There is currently concern about these growth processes; we fear there will be a collapse if growth continues unchecked and that mankind will go the way of the dinosaurs or of the mammoths. Zero growth, therefore, seems to be an ideal policy goal for society, since it apparently offers the only escape from further plundering of our planet and from total disaster. Recently, a diametrically different view has emerged. It holds that it is zero growth and zero innovation that are to be feared, because they would lead to immediate disaster. "Zero growth" involves three problems or dangers. The first one is the problem of the distribution of production, i.e., the partition of the "national pie". During previous affluent periods, growth made these problems easier to deal with since most of us could feel or see an improvement in our standard of living, even without changes in the distribution of income.

Hence, less conflict was experienced than had been encountered in other times, when more for one meant less for others. The discords between farmers and landowners and between workers and capitalists are well known examples. In a zero-growth scenario, many of these old conflicts would return. With less income, and with greater antagonism about the distribution of income, there would be less willingness to make sacrifices for improving the environment and nature. This is also the second concern or danger. We may say, therefore, that a highly developed economy requires some growth to face the challenges of serious problems arising from the distribution of wealth and from the environment.

A small part of growth arises from capital accumulation, but most is derived from increased productivity. It is here that we see the third danger. Production cannot be limited to existing levels without destabilizing society. It looks simple. We have enough, why not stop at this level? Perhaps this

might be possible in a much simpler society; in such a world we need not to curb production. However, in the real world, if we were to limit production to a no growth pattern, we would witness a collapse of our socioeconomic system and destroy our children's future, thereby achieving the very effect we wish to avert.

A. Logistic Growth

Growth may be expected to become restricted; growth tends to decrease with the attainment of higher levels of production. The typical level of production (Y) depends on its logistic growth pattern over time (t). This can be formulated as:

$$Y_{t+1} = kY_t - bY_t^2 \quad (1)$$

Economic development depends on the coefficients k and b , where k is the rate of growth and b is indicative of the resistance to worsening conditions or of the vulnerability of the industry in question. The higher the value of k , the more competitive the industry will tend to be. By setting $y = Y(b/k)$ we obtain the standard logistic growth curve:

$$y_{t+1} = ky_t - ky_t^2 \quad (2)$$

in which y varies between 0 and 1 and k between 0 and 4. The logistic curves derived from Equation 2, for different values of k , are the simple parabolas depicted in Graph a of Figure 1. As the value of k increases from 2.5 to 4.0, for example, the parabola steepens but its form does not change very much. This implies that no significant differences exist between these four situations.

However, the time series exhibited in Graphs b, c, d, and e of Figure 1 convey completely different situations, ranging from the very stable to the purely chaotic, i.e., small differences may cause enormous consequences. These time series y_t are

generated from Equation 2 for different values of k , assuming a given value of $0 \leq y_{t=0} \leq 1$ (e.g., beginning with $y_0 = 0.04$, or any other value), depicting dramatically different behaviour patterns which depend on the precise value of k . (3) For example, a very stable situation is derived when $k = 2.5$, Figure 1b. The situation is less stable but still regular when $k = 3.15$, Figure 1c. "Wilder fluctuations" are observed for $k = 3.55$, Figure 1d, and "perfect" or "complete" chaos as $k = 4$, Figure 1e.

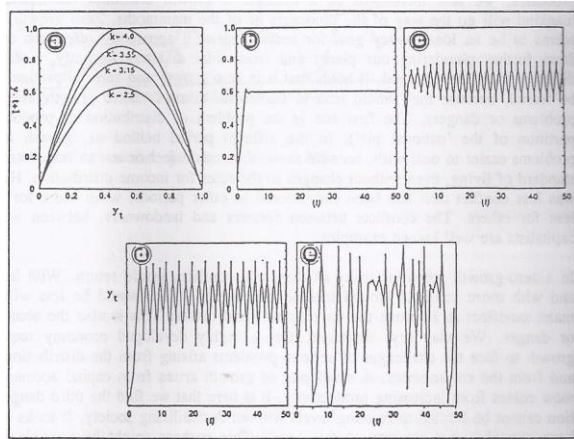

FIGURE 1

Logistic Graph

In other words, instability results when $k > 3$; the greater the value of k , the greater the instability. When $k > 3.8$, we speak of "chaos" and define (mathematically) "complete chaos" at the limiting value of $k = 4$. Manifestations of Equation 2 can be observed in nature, technology, and the economy, in the form of S-shaped or sigmoid curves as depicted in Figure 2. (1; 2; 7; 9).

B. Logistic Evolution

In nature one can observe mutations. As a consequence, new types with higher k -coefficients sometimes emerge in a population and replace older ones. Similar processes also occur in the economy, but we prefer to speak of these in terms of inventions and innovations instead of mutations. The fundamental idea, however, is the same. The k -value of some production processes may increase.

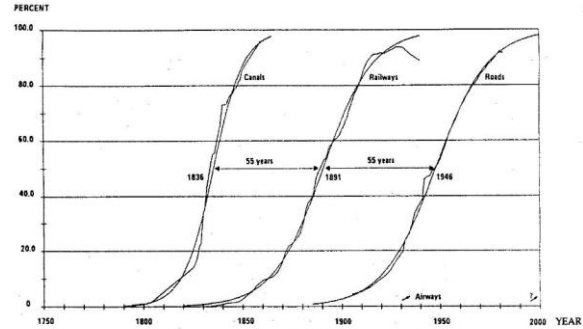

FIGURE 2
Growth of Infrastructure in the U.S.A.
(Percent saturation length)

C. Instability

Because of this rise in the k -value, our destiny changes without us immediately being aware of it. For $k > 3.2$ we observe instability in the former stable sigmoid curves and these fluctuations intensify with increasing values of k . (As shown above, for $k = 3.15$ regular fluctuations are observable, Figure 1c, but higher values of k lead to less "regularity" and increased instability.) When $k = 4$, there is complete "chaos," as previously defined. Instability is dangerous, because competitors might exploit the situation and conquer the market; the larger the k -value the greater the danger, as shown in Figure 1.

In reality we might not always see this instability. Sometimes the situation might look very stable, even though k is rather high. For example, a stream of new inventions and innovations could enable newcomers to grow, whereas older firms in the industry might suffer a setback. In this scenario, streams of new inventions and innovations may produce stable growth patterns for an industry as a whole.

2. Vitality

We can say that a population is viable if it has high vitality. This vitality depends on the degree of growth, the level of maximum production or carrying capacity, the degree of competition, the number of mutations, the resistance to disadvantageous conditions, and stability. The concept of viability can also be applied to various forms of production or industries, though it is difficult to take full account of the many aspects involved, because of their different dimensions.

It is a problem of comparing like with unlike. We can overcome this problem by using index numbers, and weighting each of the aspects in accordance with their "importance" to viability.

The vitality of a population or of a production process (industry) depends on aspects such as size and stability. We know that both, size (quantity) and stability, depend on the value of k (are functions of k), but also that they cannot be added directly. This can be resolved by using an index number of vitality, such as:

$$N_0 = w * quantity + (1 - w) * stability \quad (3)$$

where w is defined as the number of competitors.

Stability is especially important if k is high and there are no mutations (or inventions and innovations). This becomes increasingly important as the number of competitors, w , increases. We can combine all these aspects in the Newell index (6):

$$N = \frac{hw(k-1)(2.6-k) + (1-hw) \log k}{k} \quad (4)$$

$\log k$ reflects the growth of the population (or of production).

The resistance to deteriorating conditions is equal to the b -coefficient in Equation 1; it is a function of $1/k$ and, therefore, k is the denominator. Stability is indicated by $(k - 1)(2.6 - k)$. If k has a value between 1 and 2.6, the population (or production process) is very stable.

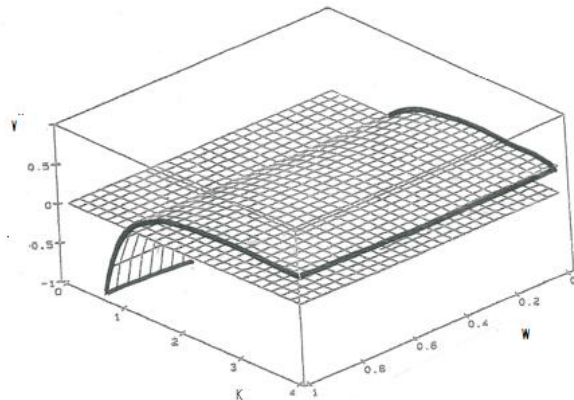

FIGURE 3

Newell Index for $h = 0$

However, this is not the case for other values of k . There are two values for h , e.g., $h = 1$ if there are no inventions and innovations. For $h = 0$, indicative of an abundance of inventions and

innovations, the resulting Newell index is exhibited in Figure 3.

The rising curve in Figure 3 depicts a picture of the traditional idea of evolution. We have climbed this mountain of evolution. Many now believe we have ascended enough; we should stop now and stay put. We no longer need ever-increasing growth curves or accelerating inventions and innovations. In other words, we should accept zero growth. But opting for zero growth and/or zero innovation would have a most unexpected and undesirable effect.

If $h = 1$ the situation is not stable for high values of k and becomes more unstable as the number of competitors (w) increases.

As Figure 4 shows, the “mountain” of Figure 3 caves in, when $h = 1$ (no inventions or innovations). Only for w -values smaller than 0.2 are positive values of N still observed. That is the case if there are almost no competitors who will try to take advantage of the situation.

In nature we will sometimes find such a situation in what we call “living fossils”. For example, the stromatolites in Australia did not change over the last 500 million years because of lack of competition.

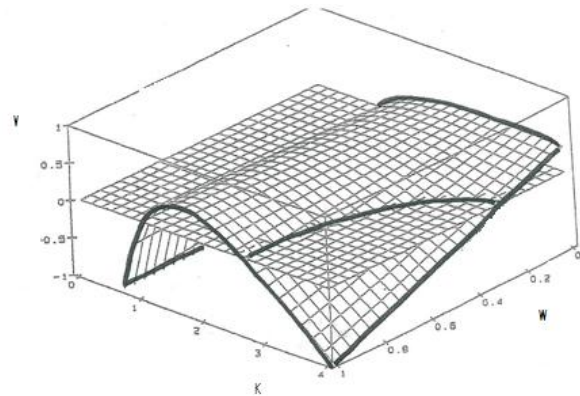

FIGURE 4

Newell Index for $h = 1$

We call them Methuselahs; Ward (10) described such creatures - they are rather rare.

Lack of inventions and innovations will lead to instability and this may prove to be fatal for the population. As indicated above, this can be observed by setting $h = 1$ in Figure 4; the mountain caves in because part of the index N falls below zero. This, in essence, is representative of the extinction of that mode of production. Only those modes of production which experience low k values survive; the others become extinct like dinosaurs. There is one exception:

for low w -values (no competition), Figure 4 shows that some high k -value populations may survive. This explains why companies attempt to corner the entire market (no competitors) or try to innovate all the time. Innovation is very important; without a stream of inventions and innovations the economy caves in. This can be illustrated with statistical data from Schumpeter, Grübler, Silverberg and Van Duyn, (6). See also Figure 5 below.

3. Competition

Competition plays an important role in the vitality of industries. There are various types of competition. Some are already operating in the phase of “ideas” or in the planning phase, others emerge once there are real products or technologies. Rivalry between innovations will develop and one will usually win out but will then face competition from other products and services. Various battles may influence the rate of growth. We may even expect evolutionary changes.

From the studies of Kuhn (4) and Mulkey (5) we know that the acceptance of new ideas is a complicated process in which “revolutions” in the power structure of the scientific community play an important role. Hence, we not only have to deal with “stoppages” in the process, but also with “goes”, both depending on the psychological and social factors that govern the acceptance of new ideas in science, industry and government. These revolutions may play an important role in the explanation of the Kondratieff or “long wave” cycles of economic expansions and contractions. They tend to have a wave length of between 40 to 60 years, which can be observed for the U.S. and Europe from 1750 on. Kondratieff cycles can be defined for the periods of 1782-1845, 1845-1891, 1892-1948 and from 1948-1993 (the latter is highly speculative). One must also expect some periods of conservative policies (what Kuhn calls “normal science”) which may ultimately result in $h = 1$, causing the whole process to grind to a halt.

The actual and predicted rates of innovation in the U.S. from 1800 to the year 2050 is depicted in Figure 5. (2) It can be observed that this rate is not constant. There are clearly high and low periods corresponding to the long waves of Kondratieff cycles in the economy (i.e., long-term business cycles of between 40-60 years duration). In other words, interruptions in the innovation process have dramatic effects on the economy. One can imagine what might happen if the processes of invention and innovation came to a halt. Some people might think that this is not a real option, but, unfortunately, it still is an important factor in some political theorizing.

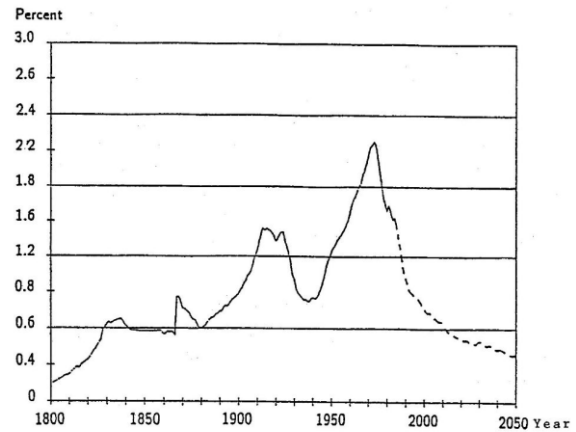

FIGURE 5
Rate of Innovation in the U.S.

The process of progress also has disadvantages. First, there are victims of revolutions and of competition. Second, systems will tend to become potentially more unstable. This may result in more cartel policies, more agricultural price policies, more social safety measures, and even more subsidies to industries. All of these can only be paid for if the system continues to function. If it comes to a halt, many of these social niceties fade away because national income decreases. Massive direct subsidies may even result in industries disappearing. For example, if the value of k were to increase from 2.6 to 3.4 (with a gift or subsidy), without inventions, innovations, or structural change ($h = 1$), total disaster would result - see Figure 4. These theoretical considerations are in accordance with the experiences of declining industries, such as shipbuilding, mining, textiles and steel in the Netherlands and other West European countries. (8)

4. Conclusion

Those who innocently advocate zero growth or zero inventions and innovations tend to overlook the importance of instability. If we want sustainability, we must, of course, prevent potential disasters as indicated in Figure 4, and, therefore, must try to ensure an unending stream of inventions and innovations. If there is no such stream, the most developed part of the economy will collapse, with disastrous consequences for society as a whole. Thus, growth and innovation do not run counter to sustainability. To the contrary, without growth and innovation there will be no sustainability. Even the absence of inventions and innovations for short periods of time would have negative consequences (depressions). Hence, sustainability would be

impossible to be achieved if society were to adapt zero growth or zero innovation policies.

Acknowledgement

The author expresses his appreciation to Professors I. Prigogine, R.M. May, P. Colinvaux, P.A. Vroon, and J.J. Krabbe for their interest in his work. He also thanks Prof. W.J.M. Heijman, and D. Wemmenhove.

References

1. Begon, Michael, et al. *Ecology*. 2nd ed. London: Blackwell Scientific, 1990.
2. Grübler, Arnulf. *Rise and Fall of Infrastructures*. Heidelberg: Physica-Verlag, 1990.
3. Hall, Nina, ed. *The New Scientist Guide to Chaos*. London: Penguin, 1991.
4. Kuhn, Thomas S. *The Structure of Scientific Revolutions*. 2nd ed. Chicago: University of Chicago Press, 1970.
5. Mulkay, M.J. *The Social Process of Innovation*. London: Macmillan, 1972.
6. Noort, P.C. van den. *Chaostheorie en Evolutie*. Delft, Netherlands: Eburon, 1993.
7. Peitgen, Heinz-Otto, et al. *Fractals for the Classroom*. New York: Springer-Verlag, 1992.
8. Voogd, Christophe de. *De Neergang van de Scheepsbouw*. Vlissingen, Netherlands: Den Boer, 1993.
9. Vroon, P.A. *De Wolfsklem*. Baarn, Netherlands: Ambo, 1992.
10. Ward, Peter Douglas. *On Methuselah's Trail*. New York: W.H. Freeman, 1992.

11/11/2011