

Development and Evaluation of Honey Extracting Machine

Babajide, N. A.¹, Ogunlade, C. A.², Oke, A. M.³ and Aremu, D. O.⁴

¹National Rice/Maize Center, c/o Federal Dept. of Agric., Moor Plantation, Ibadan.

²Department of Agricultural & Environmental Engineering, University of Ibadan, Nigeria

³Department of Agricultural Engineering, Adeleke University, Osun State, Nigeria

⁴Department of Agricultural Engineering, Federal College of Agriculture, Moor plantation, Ibadan.

E-mail: babajidenathaniel@yahoo.com

Abstract: Traditional method of extracting honey leads to reduction in nutritional value and quality thus, a honey extractor; a mechanical device that extracts honey from its comb was designed and constructed using easily available materials. The main objective of this study is the development and performance evaluation of a honey extractor. The main functional parts of the machine are net frame, wire mesh (perforation size 5mm, constructed using 1.5mm thick stainless steel of dimension 180 x 225mm), driving shaft (20 x 50mm), driving gear (diameter 21 x 17mm), control lever or operating handle (made of iron rod coated with rubber material at the point of handling to facilitate the winding process) and basket (designed to hold and spin two honeycomb frames, constructed using 1.5mm thick stainless steel, dimension 180 x 255mm placed vertically into the extractor). The honey extractor is cylindrical in shape and operated by manually turning the control lever. The time taken for honey extraction had significant effect on the performance of the honey extractor; the machine capacity, efficiency and weight of honey extracted decreases as the time taken for extraction increases, optimum values of 91.2%, 8.68 kg/hr and 456g was obtained at 32 seconds of honey extraction for machine efficiency, capacity and weight of honey extracted respectively. The average values of weight of honey extracted, weight of honeycomb remaining after honey extraction, time taken, machine efficiency and capacity of the honey extractor after a set of five experimental runs were 416.2g (± 32), 83.8g (± 31.8), 44s (± 8.5), 83.3% (± 6.4) and 6.52 kg/hr (± 1.4) respectively. The machine is portable and can be operated without any special training or technical-know-how, the machine also has the ability to preserve and leave the honeycomb undamaged after honey extraction.

[Babajide N A, Ogunlade C A, Oke A M and Aremu D O. **Development and Evaluation of Honey Extracting Machine.** *N Y Sci J* 2015;8(9):1-5]. (ISSN: 1554-0200). <http://www.sciencepub.net/newyork>. 1

Keywords: honeycomb, honey extractor, design, evaluation, efficiency

1. Introduction

Bees produce honey mainly from the nectar of flowers, plant saps and honeydew. Honey consists of a mixture of sugars mostly glucose and fructose, in addition to water (usually 17- 20%), it also contains very small amount of other substances like minerals, vitamins, proteins and amino acids. According to the National Honey Board; pure honey is so unique in taste that does not need the addition of any other sweetening substance (Hartman, 2004; Bogdanor and Stephen, 2009). Honey is the main ingredient in the alcoholic beverage meal (honey-wine or honey-beer; typically made with honey and water mixture with a pack of yeast added for fermentation FAO, 2005). Molan (1999) reported that honey has antibacterial and antiseptic constituent required in treating wounds and typically various ailments including gastric disturbances, ulcers, wounds, sore throat and burns. Honey helps to increase milk production in dairy cows, making donkey and race-horse poultry mesh and production of fish feeds. It is also used as a facial cleanser and making hand lotion (Maddock and Jenkins, 2013).

Traditional methods of extracting honey leads to reduction in nutritional value and quality; the unripe and capped honeycomb are collected at night (Bitzer, 1997) and the extraction is achieved by squeezing manually with the hand; this method seems to be the quickest for an average honey tapper who cannot afford a honey extractor or solar wax melter. However, the hand contaminates the honey and unripe honey ferments within few days after extraction, the materials collected are left untouched until the next morning and bee-wax which has become hardened at the top of the honey is removed and the harvested honey is later poured into bottles (Crane and Ethel, 2013). Generally, honey extracted traditionally does not meet up with international market standard; therefore, there is the need to construct and evaluate a honey extractor; a mechanical device that extracts honey from the honeycomb without destroying the comb. The main objective of this research work is to develop and evaluate the performance of a honey extracting machine.

2. Material and Methods

Design Consideration: main considerations in the development of the honey extractor include: choice of material of construction (stainless material was used for the food-contact parts of the machine), simplicity, efficiency and cost. The main materials used for construction and evaluation of the honey extractor are heated knife and uncapping fork (used to unseal honey cells), food-grade bucket (to collect honey out of the extractor), double sieve (collects and separates the wax and impurities as honey is poured from extractor), containers (final destination of honey before consumption), weighing balance and stop watch.

Machine Design and Description: major component parts of the honey extractor include: net frame, wire mesh (of perforation size 5mm, constructed using 1.5mm thick stainless steel of dimension 180 x 225mm), driving shaft (20 x 50mm), driving gear (diameter 21 x 17mm), control lever or operating handle (made of iron rod coated with rubber material at the point of handling to facilitate the winding process) and basket (designed to hold and spin two honeycomb frames, constructed using 1.5mm thick stainless steel, it is rectangular in shape with dimension 180 x 255mm placed vertically into the extractor. The wall of the box is perforated to allow the passage of honey during extraction process; it holds honeycomb in place during the extraction. The basket frames were held in place by welding it to the drive shaft). The gear teeth was replaced to increase the speed and the mesh was folded into a rectangular shape that would fit into the frame, a metal plate of 3mm thickness was introduced to bridge the gap created by the replacement of the gear teeth. Bolts and nuts were used where appropriate to assemble the component parts of the machine.

The honey extractor is cylindrical in shape with a frame at the top on which the control lever and bevel gears are mounted. Rotary motion was generated from the control lever mounted at the upper frame of the extractor. The gears are of two different sizes and they are arranged in a way that a complete cycle of the bigger gears at the top of the smaller gear makes the smaller gear to complete two cycles in a second (thus making the ratio of the bevel gears 3:2), the bigger one is placed in contact to the surface of the smaller gear which is coupled to the shaft of 20mm diameter having dimension of 170mm by 81mm by 255mm. Figures 1a and b shows the isometric and exploded view of the 2-frame honey extractor respectively. The plan view of the machine is presented in Plate 1a and b.

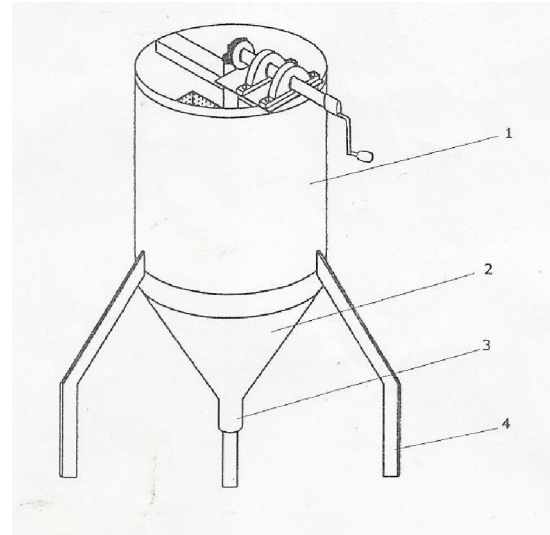

(a)

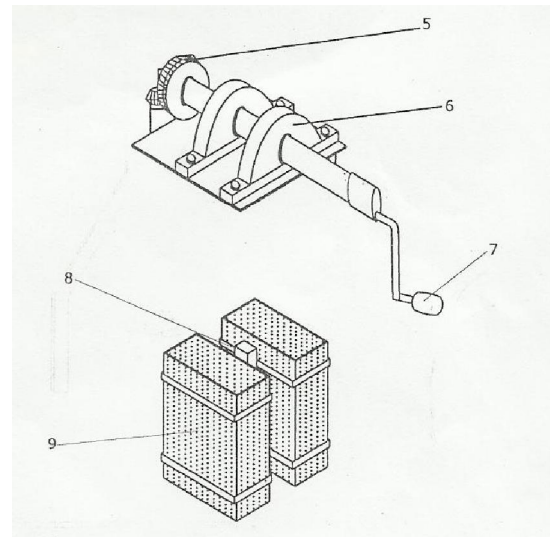

(b)

Figure 1: a- Isometric view, b-Exploded view of the honey extractor

1-Upper drum, 2-lower drum, 3-honey outlet, 4-frame, 5-gear, 6-pillow bearing, 7-handle, 8-driving shaft, 9-wire mesh

Mode of Operation of the Honey Extractor: the machine is operated by turning the hand lever after loading and measuring the time taken for the honey to spin out of the comb. As the rotor spins the mesh, the honey spins unto the wall of the drum through centrifugal force and the honey drops under gravity into the collecting chamber via the tap outlet. The primary source of power needed to spin or fling out the well packed honey from honeycomb is generated as a result of winding the handle and gears to move the drive shaft in rotary or circulatory motion and hence centrifugal force act upon the comb which is

being produced through the interaction between the handle and the gear arrangement.

$$\epsilon_e = \frac{W_h}{W_a} \times \frac{100}{1} \tag{1}$$

$$Mc = \frac{Wc}{Tt} \tag{2}$$

Where: ϵ_e is the extracting efficiency in percentage (%), W_h is the weight of honey extracted (kg), W_a is the weight of honey comb before extraction (kg), Wc is the mass of honey produced (kg) and Tt is the time taken for extraction of the honey.

Cost Estimation: the total cost of producing the honey extractor was #21,450 (143 USD), the specification and cost of all materials used for the construction of the honey extractor is presented in Table 1.

Table 1: Cost Estimation of the Honey Extractor

SN	Materials	Specification	Cost (#)
1	Driving gears and handle arrangement	-	2500
2	Stainless wire mesh	1.5mm thick	2,800
3	Stainless electrode	612	1000
4	Cutting disc	Power flex	250
5	Grinding disc	Dronco	250
6	Flat bars	50x40x 3mm	400
7	Uncapped honey	-	6000
8	Transportation	-	1950
	Workmanship	-	4000
9	Miscellaneous	-	1800
10	Paint	-	500
	GRAND TOTAL		# 21450



(a)



(b)

Plate 1: (a) and (b): Plan View of the Honey Extractor

Sample Preparation and Method of Evaluation: honeycomb was obtained from local market at Iseyin area of Oyo State, Nigeria, 500g of the honeycomb was used for the evaluation of the evaluation and a set of five (5) trial experiments were carried out. The efficiency and capacity of the machine was computed using by Equations 1 and 2 as reported by Adewumi (2007).

3. Results

A set of five trials were carried out in evaluating the machine, the result of the performance evaluation on the honey extracting machine is presented in Table 2.

Table 2: Performance Evaluation of the Honey Extractor

Run	Whb (g)	Whe (g)	Wha (g)	Tt (s)	Eff (%)	Capacity (kg/hr)
1	500	375	125	52	75	5.34
2	500	395	104	46	79.2	6.04
3	500	456	44	32	91.2	8.68
4	500	420	80	39	84	7.12
5	500	435	65	51	87	5.44
Ave	500	416	83.6	44	83.3	6.52
S.D.	-	32	31.8	8.5	6.4	1.4

Whb is the weight of honeycomb before extraction of honey, Whe is the weight of honey extracted, Wha is the weight of honeycomb after extraction of honey, Tt is the time taken for honey extraction

4. Discussions



(a)



(b)

Plate 2: (a)- honeycomb, (b)- extracted honey

At an average weight of 500g of honeycomb used for the evaluation of the machine, it was observed that the time taken for honey extraction had a significant effect on the weight of honey extracted, efficiency and capacity of the machine. The machine capacity, efficiency and weight of honey extracted decreases as the time taken for extraction increases; optimum values of 91.2%, 8.68 kg/hr and 456g was obtained at 32 seconds of honey extraction for

machine efficiency, capacity and weight of honey extracted respectively. After five experimental trials of evaluating the machine, average values of 416.2g (± 32), 83.8g (± 31.8), 44s (± 8.5), 83.3% (± 6.4) and 6.52 kg/hr (± 1.4) were obtained for weight of honey extracted, weight of honeycomb remaining after honey extraction, time taken, machine efficiency and capacity of the honey extractor respectively. The honey comb and extracted honey is presented in Plates 2a and b respectively.

5. Conclusions

A honey extractor was designed and constructed using easily accessed and available materials in order to reduce the cost of production of the machine. The machine is portable and can be operated without any special training or technical-know-how. The average values of weight of honey extracted, weight of honeycomb remaining after honey extraction, time taken, machine efficiency and capacity of the honey extractor after a set of five experimental runs were 416.2g (± 32), 83.8g (± 31.8), 44s (± 8.5), 83.3% (± 6.4) and 6.52 kg/hr (± 1.4) respectively.

Acknowledgements:

Authors are grateful to the Department of Agricultural Engineering, Federal College of Agriculture, Moor Plantation, Ibadan, Nigeria for financial support to carry out this work.

Corresponding Author:

Babajide, Nathaniel Akinrinde
National Rice/Maize Center, c/o Federal Dept. of Agric., Moor Plantation, Ibadan.
E-mail: babajidenathaniel@yahoo.com

References

- Hartmann (2004): The management of resources and marginalization in beekeeping societies of South west of Ethiopia. *Journal of beekeeping*, Vol.6, No12 Pp76-131.
- Bogdanov and Stephen (2009): Physical properties of honey at the woyback machine. *Journal of bee product*, Vol.8, No3 ISBN 682-0-311-24156-4. Pp 78-114.
- FAO (2005): Consumption of honey. *Journal health*, Vol.15 No10 Pp36-44.
- Molan, P. C. (1999): The role of honey in the management of wound. *Journal of wound care*, vol.6 No.1 ISBN825-23-6-74162-5 Pp32-41.

5. Maddock S.E. Jenkis, R.E. (2013): Honey as a sweet solution to the growing problem of antimicrobial resistance. www.google.com/apiacta/beekeeong.africa.htm (Assessed 11 August, 2015) Pp2-6.
6. Bitzer (1997): Honeycomb technology. United Kingdom: Houghton Mifflin. Pp 32-45. ISBN 875-0-641-92617-4. pp 32-45.
7. Crane E. (2013): Local method of extracting honey. *Journal of technology* Vol.8, No5, ISBN 269-0-43513-216-8.
8. Adewumi (2007): Formulae for the efficiency of a machine. *Botswana Journal of Technology*, Vol.16, No 2 pp23-28.

8/26/2015