

Design and Construction of a Tripler Circuit for a Mosquitro Zapper

¹JUMMAI D. Makama, ²M. Alpha, ³KURE N., ⁴BELLO A., ⁵DANIEL A. Thomas, ⁶ISLAMIYAT S., ⁷ADOYI E.

² & ⁶ Department of Physics, Federal University of Technology Minna, P.M.B 65, Minna

⁵ Department of Physics, Sule Lamido University, P.M.B 048, Kafin Hausa

³ Department of Physics, kaduna state university

¹ & ⁴ Department of Physics Ahmadu Bello University

⁷ Department of Physics, NDA Kaduna

Abstract: This work is aimed at reducing the number of mosquitoes through the use of electronics. The work entails the design and construction of a high voltage tripler circuit for a mosquito Zapper which can electrocute mosquitoes. It also consists of a power supply unit which is mainly used to charge the battery. The mesh dimension is 33cm by 23cm and had one inner mesh with 2 outer ones. The controls are made up of a push button and 2 mini switches and have 2 indicators for charging and power.

[JUMMAI D. Makama, M. Alpha, KURE N., BELLO A., DANIEL A. Thomas, ISLAMIYAT S., ADOYI .E. **Design and Construction of a Tripler Circuit for a Mosquitro Zapper.** *Rep Opinion* 2016;8(7):77-82]. ISSN 1553-9873 (print); ISSN 2375-7205 (online). <http://www.sciencepub.net/report>. 13. doi:[10.7537/marsroj080716.13](https://doi.org/10.7537/marsroj080716.13).

Key Words: Zapper, Tripler, Mosquito

I. Introduction

A mosquito zapper is a device used for killing mosquitoes using high voltages [4]. The mosquito zappers are in different shapes and sizes but consist of the same basic building blocks namely:

- a. A high voltage generating circuit
- b. A mesh net assembly
- c. A power supply unit
- d. A control device

The high voltage circuit generates voltages in the range of 700 - 1000 volts to a mesh assembly which traps the insects. The power supply is either battery or rectified voltage source. The control device is a switch to operate the Zapper. The mosquito Zapper has come a long way since the American National malaria eradication programme in 1947 (Centre for disease Control, 2012) [2]. The communicable disease centre CDC welcome ideas and measure that could bring about mosquito reduction and so therefore many initiatives came to be which falls under the following:

- a. Mosquito repellents
- b. Mosquito screening methods
- c. Mosquito anti lava methods

The repellent methods dealt with the use of chemicals to repel mosquitoes. Such repellent creams like “odoms” provide short duration measures. The screening methods include the development of nets and mesh wires, though expensive but effective. Lastly the anti-lava methods which are biological in nature have to do with environmental issues that are making sure that the environment is clean and no water left in cans and so on around where mosquito lava can grow.[1]

DDT was the insecticide used mostly in American mosquito reduction programs in the 1940’s

and at 1951 the country was free of malaria. The World Health Organization (WHO) took steps in that direction but was unsuccessful which brought about the various technics mentioned above. The mosquito Zapper is a screening technique with an electronic innovation to control mosquitoes entering homes. *American Heritage® Dictionary of the English Language, Fifth Edition.* (2011). [5]

II. Materials and Methods

General Circuit Diagram and Its Operation Principle

The main body resistance of most bugs and mosquitoes fall within the range of 0.70 – 0.75 Ω [3] and the required Zapper voltage is from 600 to 1200 volts ac. Figure 1 is the general circuit diagram of the Zapper.

The Zapper Circuit functions by the following principles; when the battery power is switched on, the RC oscillator produces a waveform like a square wave which switches transistor T1 On and Off and as such allows the battery current to be switched to and from the centre tapped transformer which sees the voltage as an AC Voltage. This voltage is induced into the pulse transformer secondary winding through electromagnetic induction. And because the transformer is in step up mode, the voltage is increased by 100 times to give an output which when tripled produces the required voltage that can electrocute a bug or insect. The output of the Tripler is connected to 2 meshes whereby the inner mesh called the hot mesh carries the high voltage while the outer meshes carry a ground potential.

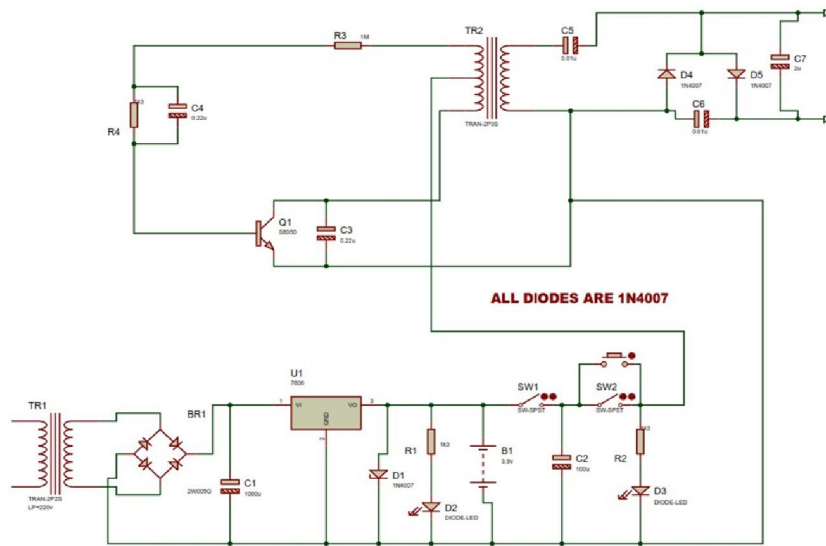

Figure 1. General Zapper circuit diagram

Tripler Circuit Design

The Tripler circuit used in this work has a rating between 2 mA -18 mA. The capacitors are C104 while the diodes were 1N4007. The basic Tripler circuit is as

shown in Figure 2. The Tripler circuit is capable of multiplication and as such the output of the transformer when tripled will bring about the required voltage to zap a bug at the Tripler output.

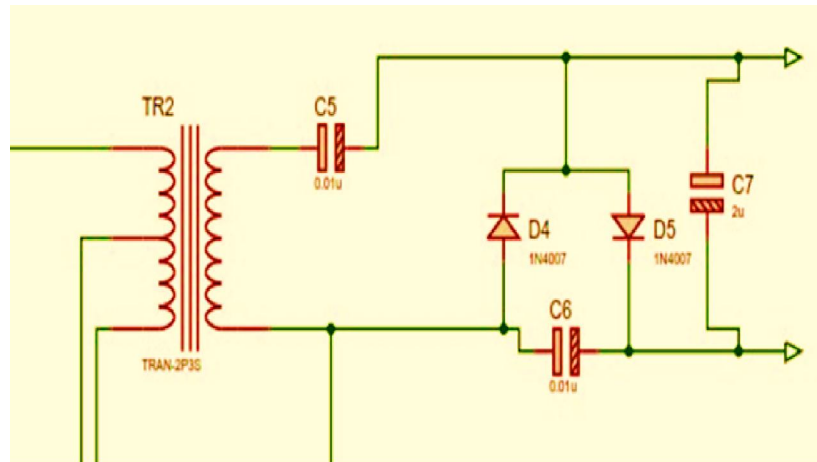

Figure 2. Transformer and Tripler Circuit Diagram

Power Supply Realization

Since a 3.9 V battery is the target load, the transformer of 12 V is chosen to meet the total power need of this work. The charging circuit can be a single component such as a 7806 regulator or a LM317. Designing the power supply, a 12V, 500 mA transformer was purchased from the local electronic market and abridge rectifier of 1A was selected from the data book. The output was filtered by a 100µf capacitor and regulated with a 7805 regulator to charge the 3.9 V battery.

As shown in Fig 1.3 the power supply circuit consists of a 220/12 V transformer with a bridge rectifier of 4 diodes, a filtering capacitor, and a 6volt regulator that is connected in parallel to a 4.5 V zener diode with two resistors R1, R2, connected in series to two LED and a 3.9 V dc battery which is also in parallel to the zener diode that is fed in such a way to protect the amount of voltage charging the battery to a maximum power of 3.9 V dc.

As the charger circuit is connected to the socket outlet the LED1 will glow indicating the presence of power

As the switch (sw1) is closed the output to battery is filtered to ensure a pure DC is archived as the current flows across the LED that is limited by the resistor R2, switch (sw2) is further closed allowing the LED2 to glow and indicate the presence of current and workability of the circuit.

The push button switch is just for additional design purpose of temporal uses. The filtered pure DC output is further sent to the inverter circuit or simple oscillator circuit through the positive output of the

battery to the centre tap of the step up transformer and the negative output of the battery to the emitter of the switching transistor.

Temporary construction

The construction of the circuit was initially carried out on bread board as shown in Figure 3 and Figure 4 with the RC oscillator and the switching transistor mounted first then the transformer mounted and the circuit was checked for correct polarity before continuing.

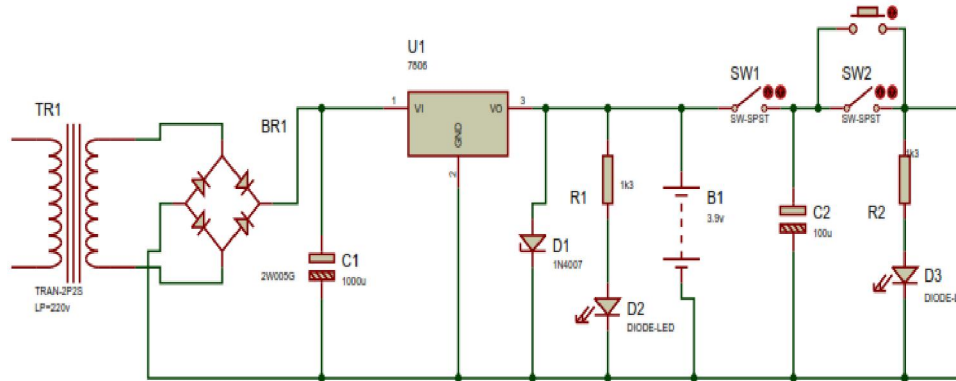

Figure 3. Power supply unit

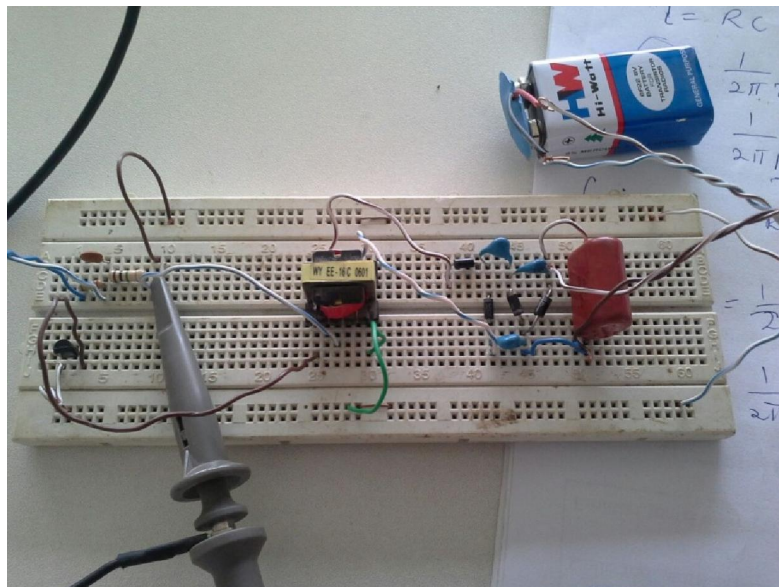

Figure 4. Assembly of temporary circuit

This stage was quickly tested and it was observed that the output of 334.2 V appeared on the meter. The Tripler circuit was then carefully assembled and the complete circuit was tested with a set of mesh for fear of the high voltage damaging the meter because the

range of the ac was 700 ac on the meter. The mesh was carefully separated and checked for short circuit. The circuit was powered and a stunned fly was used as a test insect and it was executed immediately. The picture in Figure 5 shows the test setup

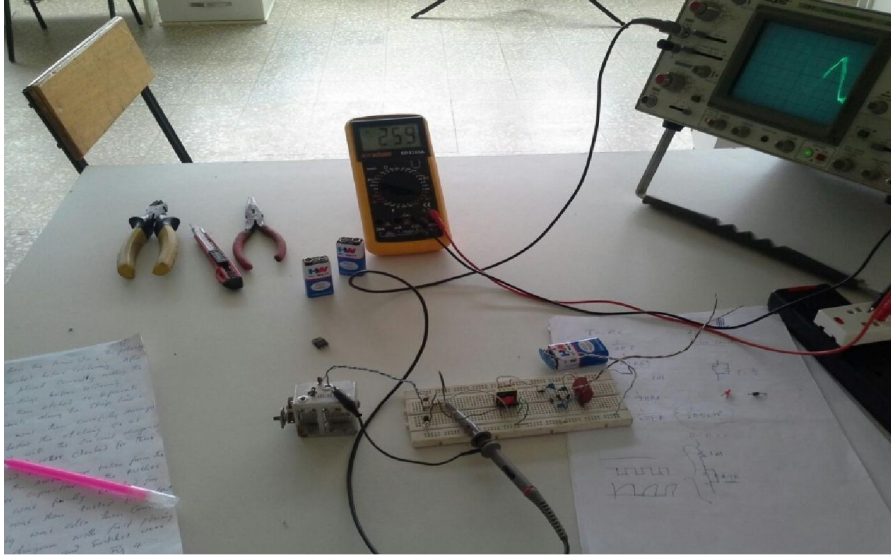

Figure 5. Test Setup

Permanent Construction

The temporary construction after being tested for outputs and performance as regards electrocuting of insects, the arrangement of the circuit was then transferred to the vero board for a permanent circuit where the component was soldered. A stripped vero board was used for the work and as the components were placed one after the other, after a careful check for the layout plan, they were soldered into place and strip lines etched to make the component form a circuit. The polarity of the transistor was checked before soldering. After this, the transformer was placed correctly noting the primary and secondary windings before soldering. The strip board was then

etched to separate the transformer terminals along the strip line. The Tripler circuit was then carefully arranged and then soldered before the etching so as to ensure compliance with the circuit diagram. PN junction diodes used were checked for their polarities then soldered.

Tapping wires to the mesh were taken from the terminals of the major capacitor to the meshes. The final circuit was finally checked for error before it was then tested for output. The power supply was also then constructed from the schematic diagram by first placing the diodes, and then the LEDs and switches were also connected using tapping wires (Figure 6).

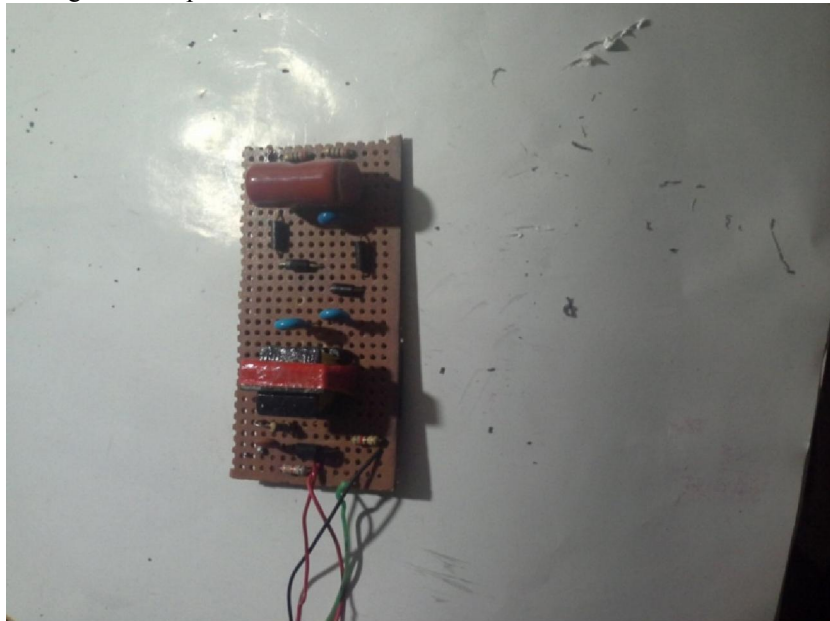

Figure 6. Zapper circuit on permanent (vero) board

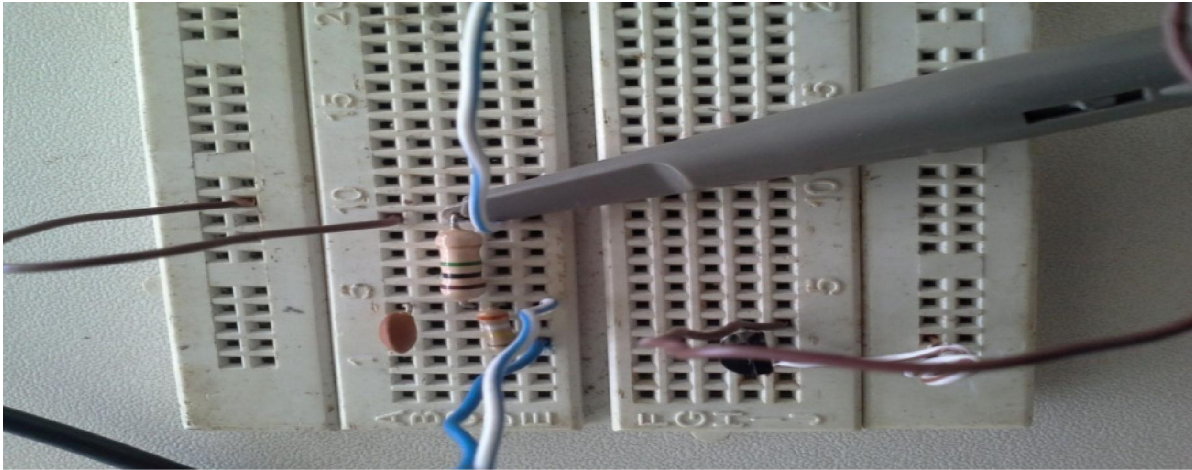

Figure 7. Rc Oscillator Test

After this test, the circuit was then connected beginning with the oscillator (RC) as shown in Figure 7.

A test on the RC oscillator showed a low frequency distorted saw wave which is used to switch transistor T1 thereby driving the transformer with collector current I_c .

Measurements/Results

During the construction of this work some preliminary measurements were carried out on the components to be sure they are in good working conditions. Table 1 shows the component test.

Table 1. Component test

Component	Value	Meter Test	Value by colour code	Remark
Resistor	1M Ω	0.999 M Ω	1M $\Omega \pm 5\%$	
Diodes	1N4007	0.585 Ω		Pass current in one direction
Transistor	S8050	B \rightarrow E \rightarrow 0.890		Good
		B \rightarrow C \rightarrow 0.699		
		B \rightarrow E \rightarrow open circuit		
		B \rightarrow C \rightarrow open circuit		
Transformer	TLB114	Low $\Omega = N_p$		Continuity
Capacitors	C104	Very high resistance		Considered open circuit

Conclusion

In conclusion of this work after looking at the design and the results obtained, it can be observed that many difficulties were encountered with the best possible oscillator component. It took several trials to achieve an oscillation that can give a reasonable voltage at the transformer output. Sometimes a high voltage could be obtained but cannot give reliable output at the Tripler than the transistor choice of which the problem was later understood to be that of the transistors operating frequency specification and

after these two problems the oscillator worked very reliably and the overall output became steady enough to electrocute by a spark of high voltage.

Recommendation

It is recommended that further work should be done involving the use of wider mesh and increase in transistor power to allow multiple windows zappers to be operated from one control.

References

1. Alvin D. Willbanks (2000) *Infrared Insect Mosquito Killing System*. Retrieved from www.google.com/patents/US6050025.
2. Christopher Buckley (2003) *History of the Bug Zapper*. Retrieved from <http://www.forbes.com/forbeslifemagazine2003/0526/088.html>.
3. Centre for Disease Control and Prevention (2012) *Elimination of malaria in the United States 1947-1951*. Retrieved from <http://www.cdc.gov/malaria/about/history/elimination/us.html>.
4. F. Folmer and Harrison L. Chapin (1934) *Insect Exterminator*. Retrieved from <http://www.google.com/patents/US1962439>.
5. Zapper. (n.d.) *American Heritage® Dictionary of the English Language, Fifth Edition*. (2011). Retrieved from <http://www.thefreedictionary.com/zapper>.

7/24/2016