

Evaluating the effectiveness of multi-layered cylindrical shells made of composite materials on the buckling load

Alireza Sadeghi¹ (Corresponding author), Mahmoudreza Hosseini Tabatabaei², Ali Ghods¹

¹Department of civil, Zahedan Branch, Islamic Azad University, Zahedan,
Iran

² Department of Civil Engineering, University of Zabol, Zabol, Iran

Abstract: The buckling load make reduce the bearing in shells. This is one of the disadvantages of the shell. Key factors influencing the buckling load of the shell are the types of structures. In this paper, the effect of the ratio of radius to thickness ratio of length to thickness of the skin buckling load of laminated composite materials is investigated. It should be added, the shell is below the static water pressure. Moreover, the interaction effects of axial load and the static water pressure is also analyzed. It must be understood, to do this is by using a geometric nonlinear analysis. Also, the software ANSYS is used.

[Alireza Sadeghi, Mahmoudreza Hosseini Tabatabaei, Ali Ghods. **Evaluating the effectiveness of multi-layered cylindrical shells made of composite materials on the buckling load.** *Researcher* 2014;6(3):51-55]. (ISSN: 1553-9865). <http://www.sciencepub.net/researcher>. 10

Keywords: cylindrical shell laminated, composite materials, buckling, geometric nonlinear analysis, static pressure water interaction.

Introduction:

Composites have low weight and high strength. Hence, their use is growing. The materials are highly resistant to corrosion. Hence, they are widely used in marine structures is facilitated. In addition, they are also used in the aerospace industry. Compared with structures made of conventional materials, the analysis and design of structures made of composite materials is more difficult. Hence, no special regulations and guidelines have been proposed. One of the most common types of structures is shells. Widespread use of these constructs, rooted in how the suitability of the load transfer them. Shell with low weight can be a huge burden to bear. The most common form of these structures, are cylindrical shells. Compared with the length and radius of the shell thickness is small. Hence, the coming into effect of pressure on them is high chance of instability caused by buckling. It must be understood, the most important factor is the complexity of the analysis and design of structural buckling. Hence, it is very important to research the factors affecting this phenomenon.

So far, extensive studies have been conducted to investigate the behavior of the shell. Then, some of them are given. Wang and Zhang to solve the problem of anisotropic laminated cylindrical shells took advantage of three-dimensional theory (Wang & Zhong, 2003). Li and Shen buckling behavior of cylindrical looked at the application of the theory (Li & Shen, 2008). Also, their skin buckling behavior of cylindrical ends of the strips were examined under different loads (Li & Shen, 2008). A. Biglou and Nouri make three-dimensional solution for the analysis of cylindrical shells made of composite

materials presented FGM (Alibeigloo & Nouri, 2010). Chaudhuri futurists' nonlinear finite element analysis of laminated shells with shear deformation introduced (Chaudhuri, 2008). Han et al. Geometric nonlinear analysis of composite shells with shear deformation began (Han et al, 2008). Alijani and Aghdam semi-analytical solution for laminated cylindrical sections review the stress presented. It also support various conditions studied (Alijani & Aghdam, 2009). Leigh and Tafresh took advantage of the finite element layer. This method is based on shear deformation theory is based first degree. They looked at the combined buckling of cylindrical shell (Leigh & Tafreshi). Shen evaluated buckling and post-buckling behavior of a cylindrical shell layers were investigated using thin shells theory (Shen, 2001). Chaudhuri et al took advantage of the theory of thin shells. Then, the solution to the buckling of cylindrical shells under internal pressure provided (Chaudhuri et al, 2008). Sofiyev et al buckling behavior of laminated shells under torsion effects were investigated (Sofiyev et al., 2003). Weicker, et al equilibrium conditions for pipe under loads generally been looked at. They took advantage of the thin shell theory. The proposed solution is accurate (Weicker, et al, 2010). Prabue and his colleagues studied the factors influencing the buckling behavior of composite cylindrical shell with initial failure to pay (Prabue, et al, 2010). Wang and his colleagues have studied the behavior of complex nonlinear dynamic buckling of cylindrical shells (Wang, et al, 2007). Nonlinear finite element analysis has been used by a number of researchers (kundu, et al, 2007; Naidu & Sinha, 2005). Andrade et al and Kima et al. conventional nonlinear analysis of

composite shells were made using the various details (Kima, et al, 2007; Andrade, et al, 2007).

In this paper, laminated skins made from composite materials are modeled in ANSYS software. Implying that the shell is below the static water pressure is important. Then, the effect of the thickness ratio of the radius and thickness of the shell buckling load is evaluated.

In addition to the above factors, the interaction of axial load and the static water pressure is investigated. Implying that, for geometrically nonlinear analysis using is doing. Prior to these studies, done correctly modeling software is measured. To do this, linear static analysis is performed on the shell. The conclusions obtained are outcome available to other researchers. In addition to the above factors, the interaction of axial load and the static water pressure is investigated. Implying that, for geometrically nonlinear analysis using is doing. Prior to these studies, done correctly modeling software is measured. To do this, linear static analysis is performed on the shell. The conclusions obtained are a number of conclusions available to other researchers.

2- Modeling and assessment of its accuracy

For finite element analysis, the strengths and shortcomings of the various elements in ANSYS software is different. Of these, the crustal component advantage of Shell-181 in this article. The element has four nodes and twenty-four degrees of freedom. Tuesday translational displacement and three rotation components comprise the node locations change. It should be added, using the Shell-181 component can be laminated composite shells with shear deformation can be modeled. Using this component, you analysis of nonlinear material behavior, and it provides great stress. The following figure shows part of the Shell-181.

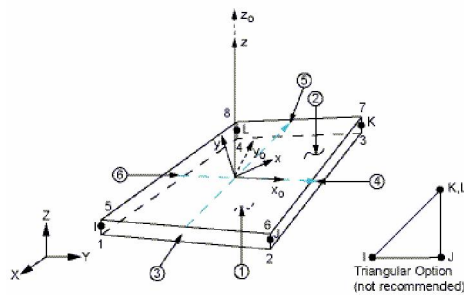

x_0 = Element x-axis if ESYS is not provided.
 x = Element x-axis if ESYS is provided.

Figure 1 - Shell-181 Component

It is obvious; we can define the coordinates of identical nodes that ye brought the triangle. It should be added at various points of the component, the thickness may vary. Points out, the primary function of the dots can be used to measure the thickness of the component. Stresses and loads on this component are shown in the following figure.

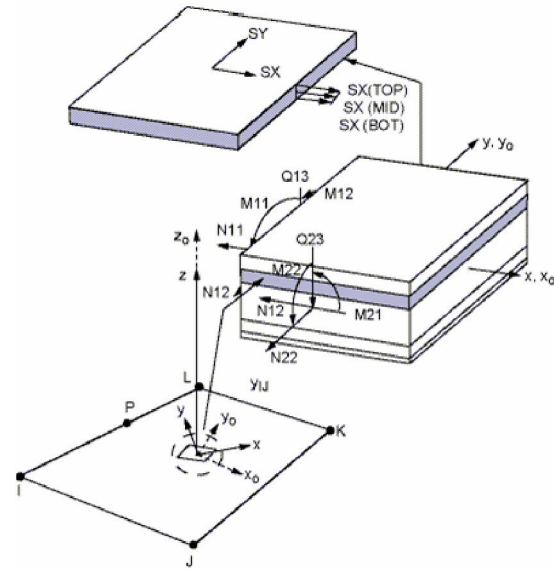

x_0 = Element x-axis if ESYS is not provided.
 x = Element x-axis if ESYS is provided.

Figure 2- component stresses and loads on Shell-181

After selecting the component skin before the Chung model and conclusions of the analysis are available in the ANSYS software modeling. It must be understood, Chang has used a linear static analysis. It should be added, Chung-dependent shell buckling problem of isotropic shells composed of four Chinese 0.90.90.0 layer is solved. Chang has the advantage that the material properties are shown in the table ahead (Chang, 1990).

Table 1 - Material properties of the model based

Anisotropic material properties		Anisotropic material properties	
$E_{11} =$	$20 \times 10^6 \text{ Psi}$	$E =$	$10 \times 10^6 \text{ Psi}$
$E_{22} = E_{33} =$	$2.1 \times 10^6 \text{ Psi}$	$G =$	$3.8 \times 10^6 \text{ Psi}$
$G_{12} = G_{13} =$	$0.85 \times 10^6 \text{ Psi}$		0.33
$G_{23} =$	$0.51 \times 10^6 \text{ Psi}$		
$\nu_{12} = \nu_{13} = \nu_{23} =$	0.21		

The shell, respectively, with an average radius, length and height equal to 5, 250 and 3641 of an inch. It must be understood, the thickness of each layer anisotropic plate with 1.25. It should be added, in addition to static water pressure, axial load, the shell is entered.

The software is only half of the shell model above, because, shell is symmetrical. Notes, for over half of the structural analysis, the boundary conditions are set. The conditions of zero displacement and zero displacement along the axis perpendicular to the axis of the shell in the middle crust are at the beginning. For the shell model, the 8000 is part of the advantage. The pattern is created around 8080. Rough indicator of the shell is modeled in software.

After modeling, for both isotropic and anisotropic mode buckling analysis is performed. The first mode of buckling and the buckling load factor of the sine wave is conclusions obtained with Chang's work. Implying, frequencies associated with the first mode of buckling

and energy it takes to make it less than other states. Thus, the first mode of buckling structures based on it. The following tables conclusions obtained are compared to the ANSYS software and presented by Chang.

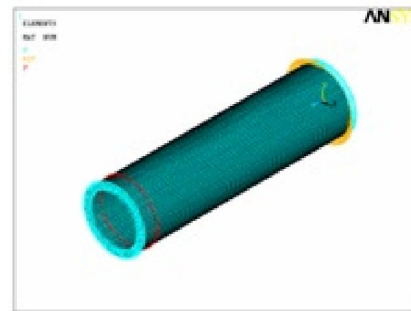

Figure 3 - shell modeling based on ANSYS Software

Table 2 - conclusions extracted and analyzed by Chang ANSYS software

Factor	Anisotropic case		Anisotropic case	
	Chang	ANSYS software	Chang	ANSYS software
Number of sine wave	2	2	2	2
the first buckling mode	36.65	31.60	17.60	41.63

It is evident that the isotropic and anisotropic case, the error in calculating the buckling load factor of the first mode 13% and 7%, respectively.

Should be aware, these errors are simplifications Chang (Chang, 1990). The previous table shows that properly modeling software. To ensure resolution of the elements, analyzes were performed for the number of different elements. The following figure shows the outcome of this analysis.

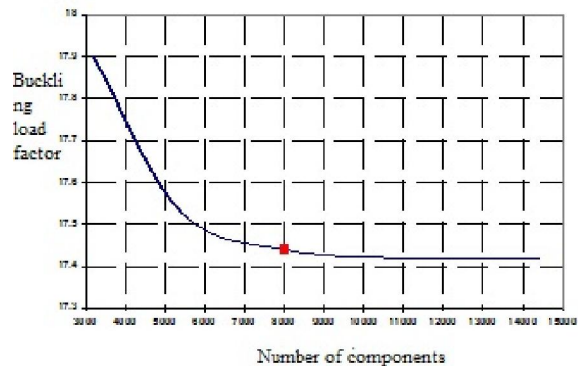

Figure 4 - Convergence analysis on the number of elements

This chart is based on the number of elements right choice is obvious. Implying that, with the increasing number of elements analyzed is high.

3- Analysis of nonlinear

To analyze the buckling and buckling modes by time, and there are two methods. In the first approach, nonlinear buckling analysis has been used. The second method uses the eigenvectors of special values. The second approach used in this study. Notes, equation specific values can be written as follows:

$$(1) \quad [K]\{\Phi_i\}=\lambda_i [S_i] \{\Phi_i\}$$

In this equality, [K] and [S] indicating the structural stiffness matrix and stiffness matrix are tensile, respectively. Eigenvector ith and its associated eigenvalue, $\{\Phi_i\}$ and λ_i , has been used respectively.

On a linear structure, it points to help the ramifications of this approach was used. ANSYS software has been properly modeled to be evaluated. Implying that, for the outcome of this work was to analyze the outcome Chang's work. To do this, the linear static analysis is considered. Then, the geometric nonlinear analysis is used. This analysis also provides the possibility to investigate the behavior after buckling. In other words, this analysis was to examine the behavior of the shell is stronger and more accurate. To analyze the deformation of the shell model should be considered for it. In this study, the first buckling mode of deformation is considered as a deformation of the crust. Then, to help build the incremental load, the load curve - Change the location for part of the shell has the greatest displacement is plotted. Finally, using this curve, the point at which a sudden deformation occurs is identified. Buckling point and these points are dependent on the load factor. It should be added, as time buckling load factor to be considered. Due to be delivered, as usual, the buckling load obtained from geometric nonlinear analysis, nonlinear analysis is less of a burden. Then, the geometric nonlinear analyses to explore the effect of some factors affecting the buckling of cylindrical shells are composed. It is assumed that the following themes are static water pressure. Implying, ANSYS software has the ability to perform nonlinear analysis.

4- Evaluation of the effect depends on the characteristics of composite cylindrical shell on the buckling

Factors affecting the behavior of shells can be placed in two groups. The first group includes features such as shell: ratios of length to thickness ratio of the radius are thick. The second group of layers characteristics such as the number and angle of your exposures. Next, the effect of the first group of agents has been assessed. The studies based on the shell shells

made of glass - epoxy and graphite - epoxy is applied. Notes, this shell features are identical.

First, the effect of thickness on the buckling load is evaluated. Analysis based on shell length to thickness ratios is different. Figure 5 plots the change in the buckling load ratio indicates the thickness of the shells. In this diagram, shell buckling load of the division are coordinated basis.

Based on these figures, increasing the load factor is the ratio of length to thickness decreases. It must be understood, the rate decreased with increasing length-to-thickness ratio is less. Typically, once the shell buckling analysis related to the ratio L/t. This result suggests that the charts.

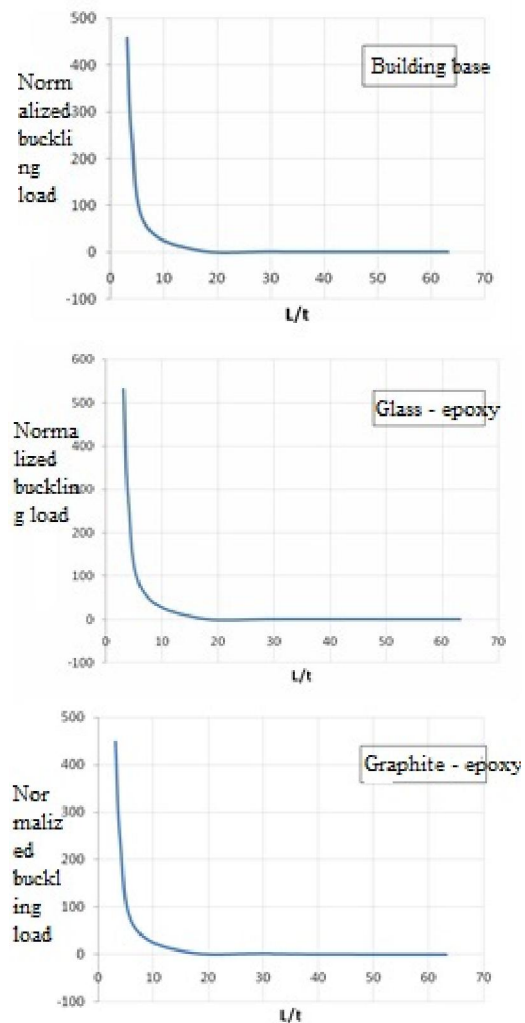

Figure 5 - coordinated buckling load changes in the ratio of length to thickness

Next, the effect of changing the radius to thickness ratio on the buckling load is investigated. The following diagram shows the result of this analysis.

Implying that, in these charts is coordinated buckling load is applied.

It is obvious that increasing the radius to thickness ratio of the buckling load is reduced. In other words, the buckling load of shell radius to thickness ratio is an inverse relationship. It is also indicative of previous work.

5 - The interaction of axial load and the static water pressure

Another factor affecting the rate of shell buckling loads are once again. The modeling is performed; the static water pressure q enters the shell base. Must balance the axial load on the shell is:

$$(2) \quad P = (q \cdot \pi \cdot r_1^2)$$

In this regard, r_1 is outer radius of the shell and P is axial load. It must be understood, the axial force can

be changed. Now, the relationship between static pressure and axial load is written:

$$(3) \quad P = S \cdot (q \cdot 2\pi \cdot r_1^2)$$

In this relation, S is the interaction of the axial force and the static water pressure.

If $S = 0.5$, indicates pure static water pressure. Next, changes the charts to change the buckling load factor interactions are presented. 0,0.1,0.3,0.5,1,3,5,10 values for S is considered in this diagram. Reminds, this plot are three types of Chinese film.

It should be added, the increase in S indicates the axial load is increased. It is evident that increasing the axial load causing buckling load is lower. This result does not depend on the alignment layers. Note that increasing the axial load shell buckling load is reduced.

3/19/2014