

## DESIGN AND EVALUATION OF AN AUTOMATIC SOLAR POWERED MOTORIZED BOREHOLE FOR JALINGO COMMUNITY, TARABA STATE, NIGERIA

Dansarki, Nanly Wesley<sup>1</sup>; Tanko, Bako<sup>2</sup>; Alexander, Ndi<sup>3</sup>; Alfred, Hilsang Kobiba<sup>4</sup> and Gregory, Moses<sup>5</sup>

<sup>1,3</sup>. Department of Electrical and Electronics Engineering, Taraba State University, Jalingo, Nigeria

<sup>2</sup>. Department of Agricultural and Biosystems Engineering, Taraba State University, Jalingo, Nigeria

<sup>4,5</sup>. Department of Agricultural and Biosystems Engineering, Taraba State University, Jalingo, Nigeria

Email: d.wesleyzing@gmail.com Tel: +234 7036420333

**ABSTRACT:** This study investigates the design and assessment of an automated solar-powered borehole for the Jalingo community. The system offers an intelligent method for monitoring water levels, presenting an efficient and cost-effective solution for water observation in local areas. It comprises a solar panel, a controller, a water level sensor, a submersible pump, and a borehole. The system monitors the water level in a tank and automatically activates or deactivates the pump based on the water level. Designed with a microcontroller and various components, including solar panels, sensors, and relays, the prototype was evaluated for its performance and accuracy. Results indicated that the system could effectively monitor and regulate the water level in the tank. Furthermore, a cost analysis revealed that the system is economical and feasible for construction in rural communities.

[Dansarki, Nanly Wesley; Tanko, Bako; Alexander, Ndi; Alfred, Hilsang Kobiba and Gregory, Moses. **DESIGN AND EVALUATION OF AN AUTOMATIC SOLAR POWERED MOTORIZED BOREHOLE FOR JALINGO COMMUNITY, TARABA STATE, NIGERIA.** *Researcher* 2026;18(4):1-9]. ISSN 1553-9865 (print); ISSN 2163-8950 (online). <http://www.sciencepub.net/researcher>. 01. doi:[10.7537/marsrsj180426.01](https://doi.org/10.7537/marsrsj180426.01)

**Keywords:** Solar-powered borehole; Automated water control; Microcontroller system; Renewable energy; Intelligent monitoring

### 1. Introduction

Water is essential for life, yet it poses significant challenges in developing countries like Nigeria. Providing potable water remains a struggle for many governments in these regions. Issues of water supply stem from both shortages and scarcity, exacerbated by the growing population. For instance, while the Sahara Desert faces severe water scarcity, the Niger Delta has an abundance of water that is often of poor quality (Ezeonu and Ogonnaya, 2013). Drinking water sources for rural and urban communities vary from surface to groundwater, depending on treatment and resource availability. Water shortages not only jeopardize human health but also consume time due to the distances to water sources. Ensuring access to clean water in rural areas can positively affect the environment and alleviate the burden of searching for safe water, often from contaminated sources (Nnaji *et al.*, 2010).

The human body is composed of 75% water in infants and 55% water in the elderly ones and not drinking enough water leads to dehydration which has many detrimental effects on the body physical and mental well-being of an individual (Chong-Su *et al.*, 2020). Studies show that dehydration decreases cognitive function in children and increases the risk for delirium in the elderly as water is also important in maintaining healthy functioning kidneys, gastrointestinal function, and heart function (Popkin *et al.*, 2010). Water is essential for life, food production and socio-economic

development. The quality of the water depends on the source and the level of contamination. Once the quality of water is reduced as a result of human activities to the extent that it is less suitable for its intended use, it is said to be polluted (Ogedengbe and Akinbile, 2007).

In many developing countries, the rural communities depend on rain water, flowing streams, stagnant ponds and shallow well while the privileged ones get water from boreholes. They have limited access to clean water. Ezeonu and Ogonnaya (2013) estimated that over 80% of illnesses in developing countries are water related. Yearly lots of death occur from the combined effects of unsafe water and poor sanitation. Providing potable water can significantly improve the quality of life and therefore became a need to be satisfied by powered pumps.

Pumping water is essential for enhancing water access in remote communities, households, hospitals, and other domestic needs. In Nigeria, erratic power supply and the economic and environmental costs of fossil fuels make water pumping increasingly challenging. This situation necessitates alternative energy sources for powering water pumps, leading to the adoption of solar energy, especially in rural areas without grid electricity. Solar energy is abundant, renewable, and pollution-free. Utilizing photovoltaic (PV) arrays for solar pumping offers an effective and sustainable method to access groundwater (Akpan *et al.*, 2024). Solar pumps, particularly high-efficiency submersible borehole pumps,

are designed to operate directly from solar panels and are suitable for various applications (Nnaji *et al.*, 2010).

Ensuring safe and sustainable access to potable water remains a major challenge for governments in developing nations, including Nigeria (Bello *et al.*, 2022). Although approximately 71% of the Earth's surface is covered by water, access to safe and clean drinking water remains inadequate. The consumption of contaminated water exposes populations to serious health conditions such as kidney diseases, typhoid fever, diarrhea, and cholera, with waterborne illnesses accounting for nearly 80% of reported health challenges in many developing regions (Etim *et al.*, 2021; Olalemi and Akinwumi, 2022). Due to the significant health risks linked to unsafe sources such as open wells, borehole water is widely regarded as a comparatively safer option for serving large populations (Shimamura *et al.*, 2022). However, many boreholes in developing communities depend on electrically driven pumps, and the persistent unreliability of electricity supply in Nigeria has resulted in the abandonment of numerous borehole installations (Yorkor and Leton, 2018). Consequently, this challenge has accelerated the transition from conventional electric-powered borehole systems to solar-powered water supply alternatives.

The major challenge facing residents of Jalingo, in North-Eastern Nigeria, is inadequate water supply resulting from low and irregular rainfall patterns. Communities living along the River Nukkai and River Lamurde have adapted to these unfavorable climatic conditions by relying on diesel-powered water pumps to transfer water into storage reservoirs. In some cases, residents manually fetch water using jerry cans and transport it-either by hand or with the aid of donkeys-to elevated tanks, from which it is distributed to households through gravity. This approach imposes continuous financial burdens due to daily fuel purchases and labor costs. Direct diversion of river water through canals into reservoirs has not been feasible because of the rivers' deep banks and frequent fluctuations in water levels. Although grid-powered pumps could serve as an alternative, their use remains limited due to poor electricity coverage in the area.

It is a common practice in Nigeria and neighbouring countries for householders to store water in overhead tanks in buildings before usage. The water is channeled to those heads with the use of pumps and subsequent usage is by flow due to gravity. When storing this water in the tanks, it is difficult to see the level of the water in the tank because of the height and opacity of the tanks in use. Hence most of the time there is an overflow of water in the tanks during pumping, thus leading to wastage of energy and water. Hence, this has led to the development of various water control schemes or systems that monitor the level of water according to the

precise settings. Therefore, efficient water monitoring has necessitated research into some water level sensing technologies, and collection methods (Beza and Hussain, 2016).

To minimize water wastage during pumping operations and to ensure adequate storage capacity for future high-demand periods, a non-contact water level monitoring and automatic pump control system has been proposed. This system is designed as an integrated electronic solution comprising two primary subsystems: the tank monitoring unit and the pump control unit.

The tank unit determines the water level using an ultrasonic sensor that operates without direct contact with water. The sensor interfaces with a microcontroller, which processes the measured data and transmits it wirelessly via a radio frequency (RF) transceiver module to the pump control unit. Upon receiving the transmitted signal, the pump unit interprets the information and regulates pump operation accordingly.

The pump control circuit is electrically connected to the starter mechanism of the pump motor. It activates the pump automatically when the water level in the overhead tank falls below a predefined threshold and deactivates it once the tank reaches the specified maximum level. This prevents both overflow and dry running of the pump. The system is designed using affordable and readily available components, making it suitable for implementation in residential and office environments. A key benefit of this non-contact automated system is its ability to manage pump operations independently, eliminating the need for manual intervention. The objective of this study is to design and assess a solar-powered borehole system integrated with automated control to provide reliable and sustainable water supply for the Jalingo community in Taraba State, Nigeria.

## 2. Material and Methods

### 2.1 Study area

The study was conducted in Jalingo Local Government Area, which lies between latitudes 8°47' and 9°01' North of the equator and longitudes 11°09' and 11°30' East of the Greenwich Meridian (Figure 1). The area is bounded by Lau Local Government Area to the north, Yorro Local Government Area to the east, and Ardo Kola Local Government Area to the south and west. The LGA covers an estimated land area of approximately 195 km<sup>2</sup>.

Hydrologically, the Jalingo metropolis is drained mainly by two rivers-River Mayo-Gwoi and River Lamurde - which originate from the mountainous terrain of Yorro LGA and eventually discharge into the Benue River near Tau village. The Lamurde River valley features several oxbow lakes formed through fluvial depositional processes. Both rivers converge within Jalingo town close to the Nukkai Bridge.

The climate of the area is classified as tropical continental, characterized by distinct wet and dry seasons. The rainy season typically begins in April and lasts until October, with an average annual rainfall of about 958 mm. During this period, relative humidity is relatively high, generally ranging from 60% to 70%. The dry season extends from November to March and is influenced by the dry and dusty northeast trade winds. Relative humidity during this season declines significantly, usually ranging between 35% and 45%, and when combined with high daytime temperatures, produces notable drying effects. Temperature patterns in the region show an average minimum of approximately 25.9 °C and an average maximum of about 32.3 °C, resulting in a mean annual temperature of around 27.9 °C.

From a vegetation perspective, Jalingo lies within the Northern Guinea Savanna, which is characterized by grasses interspersed with scattered tall trees and shrubs. Common tree species found in the area include locust bean, shea butter, eucalyptus, baobab, and silk cotton trees. The local economy is largely agrarian, supporting livestock such as cattle, sheep, and goats. The area is also a significant producer of cereal crops including maize, rice, and guinea corn, as well as tuber crops such as cassava, cocoyam, and sweet potatoes. In addition, vegetables such as okra, onions, pepper (tatashe), bitter leaves, and cabbage are widely cultivated in the region (Ezekiel *et al.*, 2023).

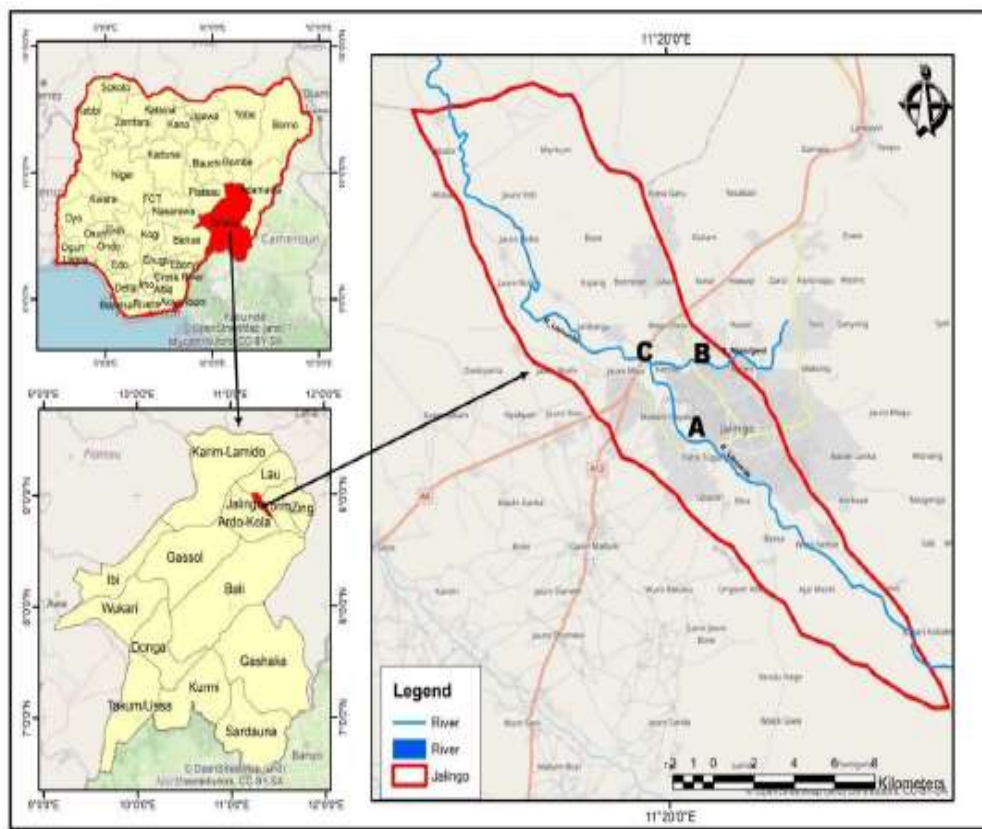

Figure 1: Map of Jalingo (Ezekiel *et al.*, 2023)

## 2.2 Borehole design

### 2.2.1 Sizing the depth of the borehole

Considering that the borehole was dug before the installation, it is paramount to determine the actual depth of the borehole. To measure the depth of the borehole, a slim hard object (25cl coke bottle) that has a weight which will suppress the up-thrust from the water was tied to a rope of about 150 m, the rope with the object were gradually sent down the hole until it reached the top water level called the static water level (SWL), the depth at which it reached the static water level was noted. It continued to go down the hole until it was observed that it has reached the depth of the borehole (DB). It was noted also. This will serve as the depth of the borehole (DB).

To get the water column (WC),  
 Static Water Level (SWL) = 82.80 m

Depth of the Borehole (DB) = 100.58 m

Water Column (WC) = DB - SWL  
 = 100.58m - 82.80 m = 17.78m

The WC is very important because it enabled us to know the actual depth to place our pump to ensure that the water pump is appropriately submerged in water with the sensor. The pump was submerged 6.09 m down the static water level to ensure that the pump and the sensor are completely submerged even during the dry season.

### 2.2.2 Sizing the water pipe

Considering the size of the water outlet from the pump, a 2.5 mm Plastic pipe was used. Plastic pipes were used to avoid rust which is evident with metallic pipes. This is used to channel the water from the borehole to the reservoir. Each full length of the pipe is 5.49 m. To determine the exact length of pipes needed we used the parameter from the sizing of the borehole.

Static Water Level (SWL) = 82.80 m

Depth of the Borehole (DB) = 100.58 m

Water Column = 17.78 m

From sizing of the depth of borehole, the SWL is 82.80 m, WC is 17.78 m and the length of the pump plus the sensor when measured is 1.22m and it must always be submerged in water. To ensure that the pump and the sensor are always submerged in water even during the dry season, they have to be submerged 6.09 m into the water column (WC). To size the pipe;

Total Length of the pipe (TLP) = SWL + 6.09m = 82.80 m + 6.09 m = 88.89 m

A pipe length of 88.89 m is needed and each full length of the pipe is 5.49 m.

To get the number of 5.49 m pipe that needed,

Number of full length pipe needed =  $\frac{\text{Total length of pipe}}{5.49} = \frac{88.89}{5.49} = 16$

## 2.3 Power unit design

### 2.3.1 Hydraulic energy

The total dynamic height (TDH) can be computed using Equation (1) as stated in Yorkor and Leton (2018). Using the data of the borehole aforementioned.

$$\text{TDH} = \text{TVH} + \text{hf} \quad (1)$$

Where; TVH is the total vertical, which is the sum of depth from water level to pump and height of tank of the pump to the top of the tank, hf is pipe friction loss, which was assumed to be 2% of TVH (Yorkor and Leton, 2018), using the data of the borehole aforementioned.

Equation (2) was used to calculate the hydraulic energy (Eh) required to pump water from the well to the TDH as stated in Frenjo *et al.* (2017).

$$\text{Hydraulic energy, } E_h = \rho \times g \times v \times \text{TDH} \quad (2)$$

Where;  $\rho$  = density of water (1000 kg/m<sup>3</sup>),  $g$  = acceleration due to gravity (9.81 kg/m<sup>3</sup>),  $v$  = required volume of water tank (1.2 m<sup>3</sup>/day). This volume of the water tank was chosen as provided by Enuneku *et al.* (2021) for homes and public institutions' water daily consumption in rural areas.

### 2.3.2 Solar power system sizing

A pump capacity (Pp) that can pump water above the total dynamic head was computed using Equation (3) as stated in Frenjo *et al.* (2017). It was assumed that the fan heat expeller power (Pe) will be 10 W also, 2 hours assumed for the time taken (t) to fill the water storage tank.

$$\text{Total energy (Et)} = (\text{Pp} + \text{Pe}) \times t \quad (3)$$

The Total PV panels' energy needed per day (Ed) is the total appliances in watt-hours per day was computed using Equation 4 (Tamrakar *et al.*, 2022).

$$\text{Ed} = 1.3\text{Et} \quad (4)$$

### 2.3.3 PV array sizing

The peak power output (Wp) of a photovoltaic (PV) module is influenced by both the module rating and the climatic conditions of the installation site. For Nigeria, a panel generation factor (PGF) of 3.596, as reported by previous studies, was adopted for the design calculations. The total required watt-peak capacity of the PV array was computed using Equation (5).

$$\text{Wp} = \frac{E_d}{\text{PGF}} \quad (5)$$

Where;  $E_d$  represents the daily energy demand (Wh/day).

Based on commercially available modules rated at 200 W, the number of PV panels required was determined using Equation (6).

$$\text{N}_{\text{pv}} = \frac{\text{Wp}}{\text{P}_{\text{panel}}} \quad (6)$$

Where;  $P_{\text{Panel}}$  denotes the rated power of a single PV module (200 W).

### 2.3.4 Inverter sizing

To ensure safe and reliable operation, the inverter capacity was selected to be approximately three times the rated power of the pump motor. This oversizing accounts for the high inrush current typically required during motor startup and prevents inverter overloading. The selected inverter rating therefore accommodates both the continuous operating load and the surge demand.

### 2.3.5 Battery sizing

Battery capacity was determined based on the required autonomy period of the system. The usable battery capacity ( $B_C$ ) was calculated using Equation 7 (Ignatius *et al.*, 2023).

$$B_C = \frac{E_t \times D}{\eta_b \times \eta_d \times V} \quad (7)$$

Where;  $E_t$  = total daily energy consumption (Wh/day),  $D$  = required days of autonomy (0.5 day considered in this study),  $\eta_b$  = battery efficiency (0.85),  $\eta_d$  = permissible depth of discharge (0.6) and  $V$  = nominal battery voltage (12 V).

The efficiency and depth of discharge factors were incorporated to ensure realistic and safe battery operation.

### 2.3.6 Solar charge controller sizing

The specifications of the selected PV module used in the design were:

$$P_m = 200\text{Wp},$$

$$V_m = 37.8\text{V},$$

$$V_{oc} = 44.64\text{V},$$

$$I_{sc} = 6.05\text{A}.$$

The required current rating of the solar charge controller rating (CCR) was determined using Equation 8 (Bhoye and Sharma, 2014).

$$\text{CCR} = N_{pv} \times I_{sc} \times 1.3 \quad (8)$$

A safety factor of 1.3 was applied to account for variations in solar irradiance and potential current increases under peak sunlight conditions.

## 2.4 Automatic water level control system

An automatic water level control system was developed to regulate water levels in both overhead and underground storage tanks through an electronic switching mechanism. The system enables automatic refilling of the tanks without the need for manual operation. It is configured to activate the pump whenever the water level drops below a predetermined threshold and to automatically deactivate the pump once the tank reaches its maximum capacity, thereby preventing overflow and unnecessary energy consumption.

The control unit was designed using a microcontroller integrated with several supporting components, including a solar power source, water level sensors, and relay switches. The system architecture consists of a solar panel for energy supply, a controller unit for processing signals, water level sensing devices for detecting tank levels, and a pump responsible for water delivery. The controller continuously monitors the water level and automatically switches the pump on or off depending on the detected level.

In addition, the system incorporates a display interface that allows users to observe the current water level in the storage tank. The main components utilized in the design include fluid level detection sensors, a microcontroller integrated circuit (AT78S50), a regulated power supply unit, relay switches, and light-emitting diodes (LEDs) for system indication. The complete schematic diagram of the proposed system is presented in Figure 2, while the circuit configuration of the water level controller is illustrated in Figure 3.

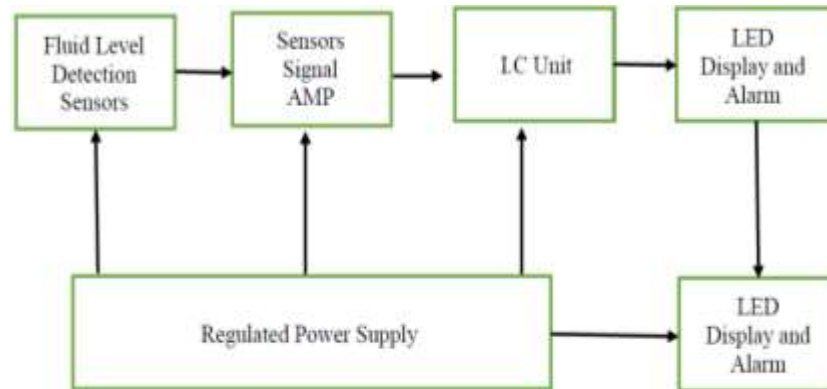

Figure 2: Block Diagram of the Automatic Water Pumping System

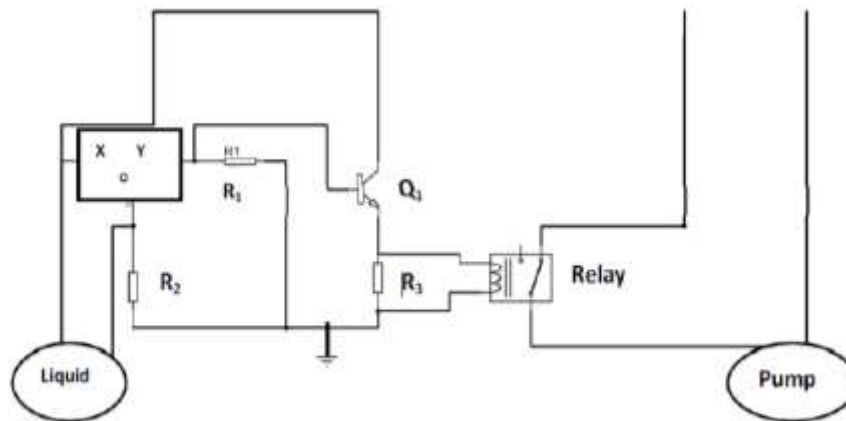

Figure 3: Circuit Diagram of the Water Level Controller

### 3. Installation and Testing of the Automatic Solar Powered Borehole

#### 3.1 Materials for installation

Once the borehole is drilled to the aquifer level, the subsequent stage involves installing a pumping system capable of lifting water from the borehole to a storage reservoir. In this study, solar energy was adopted as the primary power source. Solar radiation is converted into electrical energy using photovoltaic (PV) panels, which supply power to a DC pump responsible for lifting water through connected pipelines to the storage tank.

The main components used for the installation include the Grundfos SQFlex Pump, 12 V 85 W solar panels, a float switch, the Grundfos CU 200 Controller and 2.5 mm plastic pipes for water conveyance.

##### 3.1.1 Grundfos SQFlex pump

The system utilizes the Grundfos SQFlex Pump, which is specifically designed for operation with renewable energy sources such as solar power. The pump can operate directly on a DC input within the range of approximately 30-300 VDC. It can function with a series connection of photovoltaic modules producing a minimum peak voltage of about 30 V; however, higher operational efficiency is typically achieved when the supply voltage exceeds 100 VDC. The SQFlex pump is suitable for installation in boreholes with a minimum diameter of 3 inches. Additionally, it is equipped with built-in protection mechanisms against dry running, overloading, and overheating, which enhances operational reliability and prolongs the lifespan of the system.

##### 3.1.2 Photovoltaic array

The photovoltaic array used in this installation consists of eight solar panels connected in series using 2.5 mm single-core cables in order to obtain the required output voltage. Each solar panel has an operating voltage of 17 V, an open-circuit voltage of 21.6 V, a power rating of 85 W, and an operating current of approximately 5 A. The total output voltage of the array is obtained by multiplying the voltage rating of a single panel by the number of panels

connected in series ( $17\text{ V} \times 8 = 136\text{ V}$ ). In practice, the actual output voltage may fluctuate depending on the intensity of solar radiation. Under strong sunlight conditions, the output voltage of individual panels may reach 20 V or higher, thereby increasing the overall system voltage.

### **3.1 Materials for installation**

After the borehole has been carefully dug down to the aquifer level, the next step is installation of a system that will be pumping water out of the hole, into a reservoir. The power source used for this purpose is solar energy which is converted into electrical energy through the aid of photovoltaic arrays, this powers the DC pump which pumps out water from the hole through the connected pipes. The materials used for this installation are; Grundfos SQFlex pump, 12V 85W Solar panel, Float switch, CU 200 controller and 2.5 mm plastic pipes.

#### **3.1.1 Grundfos SQflex**

The pump used in this installation is Grundfos SQFlex pump which can be directly powered by solar. Input power of the range 30-300 voltage direct current (VDC) can be used to run the pump. They can operate on a series string of photovoltaic (PV) modules with a total peak power voltage over 30 volts, but the pump efficiency will be much higher at voltages over 100 VDC. SQFlex will fit into a 3 inches well or borehole. The SQFlex has built-in protection from dry-running, overload and overheating.

#### **3.1.2 Photovoltaic array**

The eight solar panels were connected in series with the aid of 2.5 mm single core cable to achieve the desired output voltage. Each of the solar panel used for this installation has an operating voltage of 17V, open circuit voltage of 21.6V, power rating of 85W and an operating current of 5A. Output voltage is equal to voltage rating multiplied by the number of panels connected in series ( $17 \times 8 = 136\text{ V}$ ). In practical, the voltage varies depending on the intensity of the sun. This is so because the solar panel can give an output voltage of up to 20 volts or more depending on the intensity of the sun.

#### **3.1.3 Float switch**

The float switch is employed to monitor the water level within the reservoir. It is electrically connected to the CU200 Controller. When the water rises and submerges the float switch, a signal is transmitted to the controller indicating that the reservoir is full, prompting the pump to stop operation. Conversely, the pump automatically resumes when the water level drops below the predetermined threshold.

#### **3.1.4 CU200 controller**

The CU200 Controller serves as the central control unit of the system. It is a user-friendly interface that facilitates two-way communication between the pump, float switch, and solar modules while continuously monitoring system performance. The controller features built-in diagnostics for detecting faults, dry running, and operational status, as well as input from the level switch. Communication between the CU200 and the pump is conducted through the pump's power supply cable. The CU200's display provides real-time information on key parameters, including pump operation, tank full status, input power (in watts), and alarms for dry running, overvoltage, overload, or overheating conditions.

### **3.2 Installation and Testing**

With all necessary components ready, the installation begins by connecting the photovoltaic panels in series using 2.5 mm single-core black and red cables. This configuration ensures higher voltage for improved pumping efficiency. The PV array is mounted securely on a metallic frame, which is positioned to maximize exposure to sunlight throughout the day. For connecting the controller to the pump at the borehole, a 3 mm three-core cable approximately 88.89 m in length is used. This length accommodates the vertical drop along the pipeline from the controller to the pump as well as an additional 6.09 m above ground to the location of the control box, ensuring sufficient cable reach for safe and reliable installation.

The float switch also known as the level switch dictator is hung inside the reservoir and the terminals is channeled neatly down to the box for connection to the controller unit. A marine rope is fasten to the end of SQFlex pump for easy lowering down the hole, with the aid of the fastened marine rope the pump and the pipes are sequentially connected and lowered down the hole starting from the outlet of the pump. When the final pipe must have been connected the pump will be place 6.09 m down the SWL. The hole is covered and the remaining marine rope is fasten to the body of the cover, this will ensure that the pump is safety placed and gives easy access during maintenance. The remaining 6.09 m pump terminal cable is channeled to the box for termination to the controller. Figure 4 is the schematic diagram of the automatic solar powered motorized borehole.

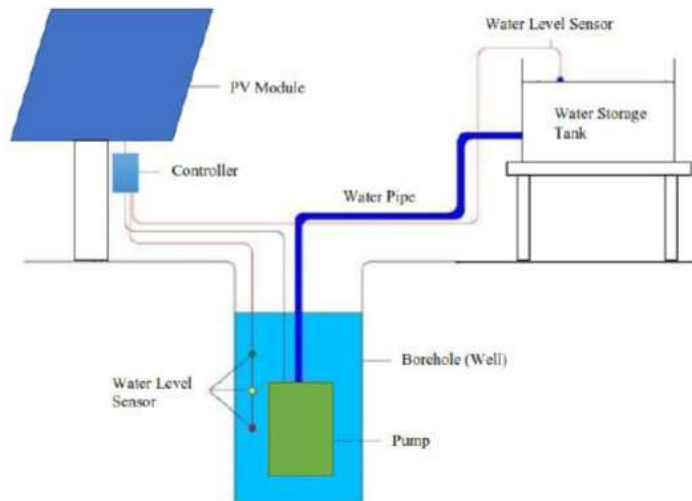

Figure 4: Schematic Diagram of the Automatic Solar Powered Motorized Borehole

The pump terminals are terminated to the CU200 controller followed by the float switch while the solar panel array terminal is the last to be terminated. The CU200 is placed inside the box to protect it from harsh weather. Finally the box is locked to avoid unauthorized personnel from having access to the controller system. The system connected to the solar panel array terminal, is meant to start running. The installation was completed very late in the evening and considering that the insolation level has reduced, the LVD (Low Voltage Disconnect) mode was activated by the controller due to low input voltage. The next day when the insolation level becomes high the LVD mode is automatically deactivated and the pump started running. The system was monitored until around 2 pm when the float switch indicated that the reservoir is filled up. Automatically the system stopped running, when the water level reduced due to collection of water by the community, the level indicator signaled the controller to start the pump.

#### 4. Conclusion

An automatic solar-powered borehole system has been successfully designed, implemented, and evaluated. The system operates autonomously, providing a reliable and continuous water supply to the community without requiring manual intervention. Its automated functionality distinguishes it from conventional water supply methods powered by unstable grid electricity or diesel generators, which depend on operators for fuel and control. The system is suitable for deployment in remote or difficult-to-access locations, including forests, deserts, mountainous regions, offshore platforms, and rural communities. Once installed, it requires minimal maintenance and operates in an environmentally sustainable manner, making it a practical and eco-friendly solution for water supply challenges.

#### Conflict of interest

The authors declare that the research was conducted in the absence of any commercial or financial relationships that could be construed as a potential conflict of interest.

#### Acknowledgments

This study was carried out with the support of the Tertiary Education Trust Fund (TETFund), Institutional Based Research (IBR) Project Grant, 2025.

#### References

- Akpan, U.S.; Ekott, E.E.; Udofia, A. and Inyang, A. (2024). Design And Implementation of Automatic Non-Contact Water Level Monitoring With Automatic Pump Control System. *Journal of Multidisciplinary Engineering Science Studies (JMESS)*, 10(1): 5322- 5331.
- Bello, U.; Yawas, D.S. and Oyedeji, A.N. (2022). Assessment of Perceived Performance of Solar-Powered Borehole Projects in Nigeria. *Management Science and Business Decisions*, 2(2): 32-43. <https://doi.org/10.52812/msbd.47>
- Beza, G. and Hussain A.A. (2016). Automatic Water Level Sensor and Controller. *International Journal of Applied Engineering Research*, 11(6): 4423-4427
- Bhoye, H. and Sharma, G. (2014). An Analysis of One MW Photovoltaic Solar Power Plant Design. *International Journal of Advanced Research in Electrical, Electronics and Instrumentation Engineering*, 3(1): 6969-6973.
- Chong-Su, K.; Woo, Y.C. and Dong-Mi, S. (2020). Dehydration Impairs Physical Growth and Cognitive Development in Young Mice.

- Journal of Multidisciplinary Digital Publishing Institute*, 12(13): 1-11.
- Enuneku, A.A.; Anani, O.A.; Job, O.; Kubeyinje, B.F.; Ogbomida, E.T.; Asemota, C.O.; Okpara, B.; Imoobe, T.; Ezemonye, L.I.; Adetunji Charles Oluwaseun, A.C. and Hefft, D.I. (2021). Mapping Soil Susceptibility to Crude Oil Pollution in the Region of Delta, South-South Nigeria: A Proportional Study of Environmetrics, Health, Ecological Risks, and Geospatial Evaluation. *Scientific African*, 14: e01012. <https://doi.org/10.1016/j.sciaf.2021.e01012>
- Etim, M.A.; Babaremu, K.; Lazarus, J. and Omole, D. (2021). Health Risk and Environmental Assessment of Cement Production in Nigeria. *Atmosphere*, 12(9). <https://doi.org/10.3390/atmos12091111>
- Ezekiel, B.B.; Adelalu, T.G.; Christopher, J.N. and Alhassan, T. (2023). Assessment of Agro Allied Chemical Pollution on Surface Water Quality of River Lamurde and Mayo-Gwoi, Jalingo, Taraba State, Nigeria. *Advances in Environmental and Engineering Research*, 4(1): 1-20. <https://doi.org/10.21926/aeer.2301008>
- Ezeonu, S.O. and Ogonnaya, E.O. (2013). Construction and Installation of Solar Powered Borehole for a Primary Health Centre. *Journal of Innovative Research in Engineering and Sciences*, 4(3): 491- 494.
- Frenjo, A.; Wogasso, A.; Rajesh, R. and Muthiya S.J. (2017). Designing and Developing Solar Energy Operated Water Pump for Small Scale Irrigation. *International Journal of Chemical Sciences*, 15(4): 194.
- Ignatius, I.E.; Austine, O.; Ebunilo P.O.B.; Egware, H.O. and Akhator, P.E. (2023). Design and Construction of a Mobile Solar-Powered Water Pumping System Suitable for Niger Delta Rural Dwellers. *Iconic Research and Engineering Journals*, 7(6): 235-245.
- Nnaji, M.; Nnaji C.E. and Unachukwu, G.O. (2010). Solar Water Pumping for Sustainable Agricultural Development in Nigeria. *Nigeria Journal of Solar Energy*, 21: 169-172.
- Ogedengbe, K. and Akinbile, C.O. (2007). Performance Evaluation of Solar Radiation as Alternative Disinfection Technique for Well Waters in Ibadan, Nigeria. *Journal of Engineering and Applied Sciences*, 2(5): 915-919.
- Olalemi, A. O. and Akinwumi, I. M. (2022). Microbial Health Risks Associated with Rotavirus and Enteric Bacteria in River Ala in Akure, Nigeria. *Journal of Applied Microbiology*, 132(5), 3995-4006. <https://doi.org/10.1111/jam.15497>
- Popkin, B.M.; D'Anci, K.E. and Rosenberg, I.H. (2010). Water Hydration and Health. *Nutrition Reviews*, 68(8): 439-458.
- Shimamura, Y.; Shimizutani, S.; Taguchi, S. and Yamada, H. (2022). Economic Valuation of Safe Water from New Boreholes in Rural Zambia: A Coping Cost Approach. *Water Resources and Economics*, 37. <https://doi.org/10.1016/j.wre.2021.100192>
- Tamrakar, E.; Patel, R.N. and Choudekar, P. (2022). Customized Design of Micro-Inverter Based Solar Photovoltaic System for Small Houses in Developing Nations. *Renewable Energy Focus*, 42: 178-189. <https://doi.org/10.1016/j.ref.2022.06.004>
- Yorkor, B. and Leton, T.G (2018). Solar Water Supply for Rural communities in River State, Niger Delta of Nigeria. *International Journal of Energy and Environmental Research*, 6(3): 49-64.